

## Application Note

# Using the CS5480/84/90 Energy Measurement IC with Rogowski Coil Current Sensors

### 1. Introduction

Rogowski coil, or  $di/dt$ , current sensors have been increasingly implemented in AC power and energy measurement applications because of their exceptional linearity, high current capacity and dynamic range, light weight, and electrical isolation. The Cirrus Logic energy measurement ICs CS5480, CS5484 and CS5490 support various types of Rogowski coils.

This application note presents accuracy results from testing the CS5480 with three different types of Rogowski coil sensor. The CS5484 and CS5490 use the same core technology. Testing results of the CS5484 and CS5490 show nearly identical results. Comparable power meters were constructed using the CS5480 and three Rogowski coils: Pulse Electronics PA3202NL, TAEHWATRANS TR9L, and Sentec Mobius. Accuracy test results are presented that demonstrate that the CS5480 can achieve an energy measurement accuracy of 0.1% over a 4000:1 dynamic range when interfaced to a Rogowski coil.

### 2. Rogowski Coil Overview

A Rogowski coil current sensor is a helical coil of wire wrapped around an AC line conductor and used to measure the flow of electric charge through the conductor. Since a Rogowski coil has an air core instead of an iron core, the measurements show excellent linearity with practically no saturation problems. In addition, the Rogowski coil rates highly for electrical isolation from the buss bar, and is light weight with low material cost. The Rogowski coil is increasingly being implemented when measuring high-current AC power and energy.

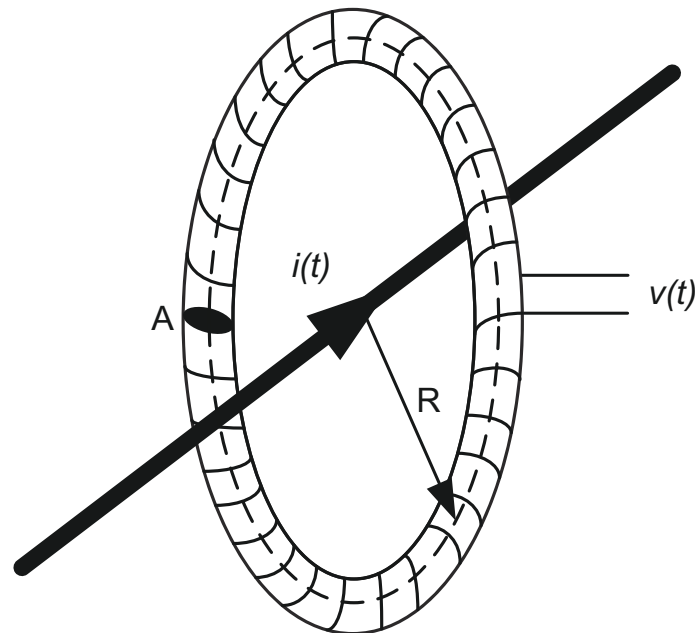

Figure 1. Rogowski Coil Current Sensor

The voltage  $v(t)$  that is induced in the Rogowski coil is proportional to the rate of the change of current ( $di(t)/dt$ ) and is based on Faraday's law. The voltage  $v(t)$  produced by a Rogowski coil is calculated using Equation 1:

$$v(t) = \left( \frac{-AN\mu_0}{l} \right) \left( \frac{di(t)}{dt} \right) \quad [\text{Eq. 1}]$$

where,

A = Area of each small loop

N = Number of turns

l =  $2\pi R$  and is the length of the winding

$\mu_0$  = Permeability of free space

When the AC line current, I, is a 50Hz or 60Hz sinusoidal, Equation 1 can be simplified to Equation 2.

$$V = kI \quad [\text{Eq. 2}]$$

where

k = Sensitivity constant that represents the output voltage per ampere at 50Hz or 60Hz.

Most Rogowski coil manufacturers provide a sensitivity constant for the coil. See Table 1:

Model	Manufacturer	Output Voltage/Ampere at 50Hz
PA3201NL	Pulse	416 $\mu$ V/A
TR9L	Taehwatrans	1.7mV/A
Mobius	Sentec	80 $\mu$ V/A

**Table 1. Rogowski Coil Parameters**

### 3. Rogowski Coil Support

Since the output of a Rogowski coil is proportional to the derivative of the instantaneous primary current, an integrator is required to retrieve the original current signal. The CS5480 incorporates selectable digital integrators for both current channels. The integrators have the frequency responses illustrated in Figure 2 to compensate for the 90 degree phase shift and 20dB/decade gain generated by the Rogowski coil.

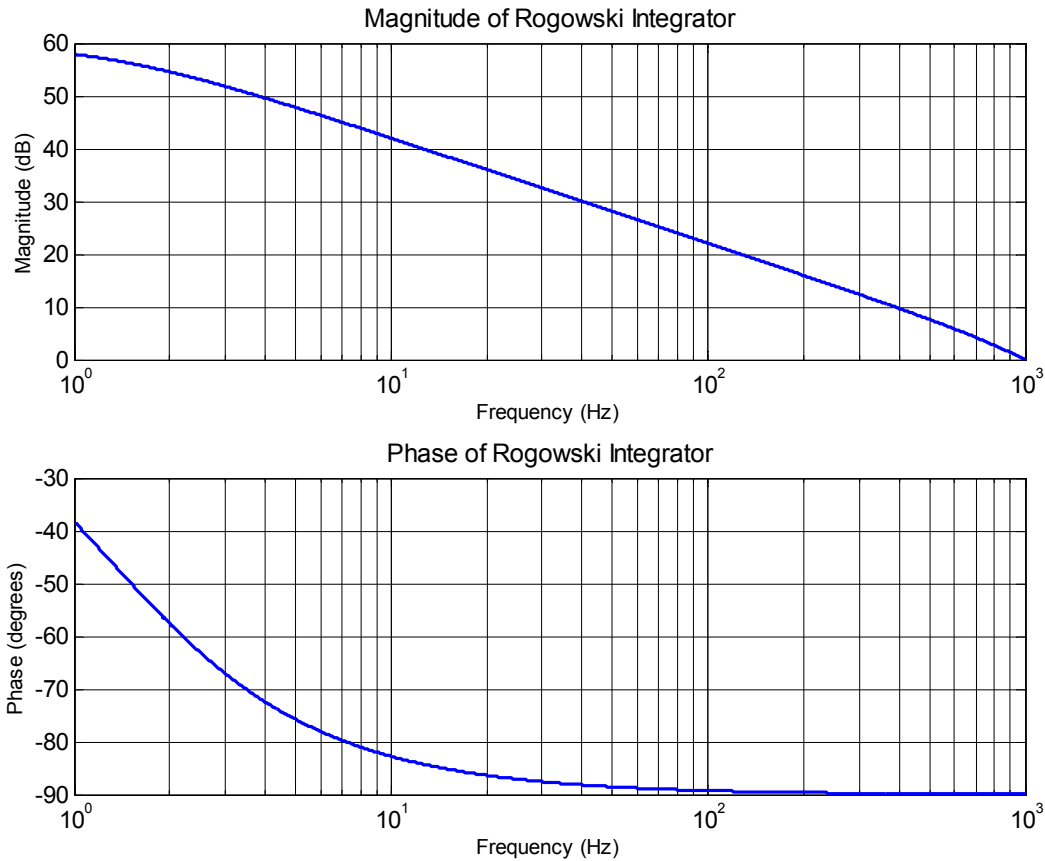

Figure 2. Frequency Response of the Digital Integrator

### 3.1 Connection Between a Rogowski Coil and the CS5480

Since the Rogowski coil has an inherent 20dB/decade gain, a single-pole low-pass RC anti-aliasing filter is not capable of attenuating the high-frequency noise. Two cascaded low-pass RC filters are required to produce a 40dB/decade attenuation at high frequency. Figure 3 illustrates the typical connections between a Rogowski coil sensor and the CS5480. If the Rogowski coil has a shielding lead, it should be connected to ground.

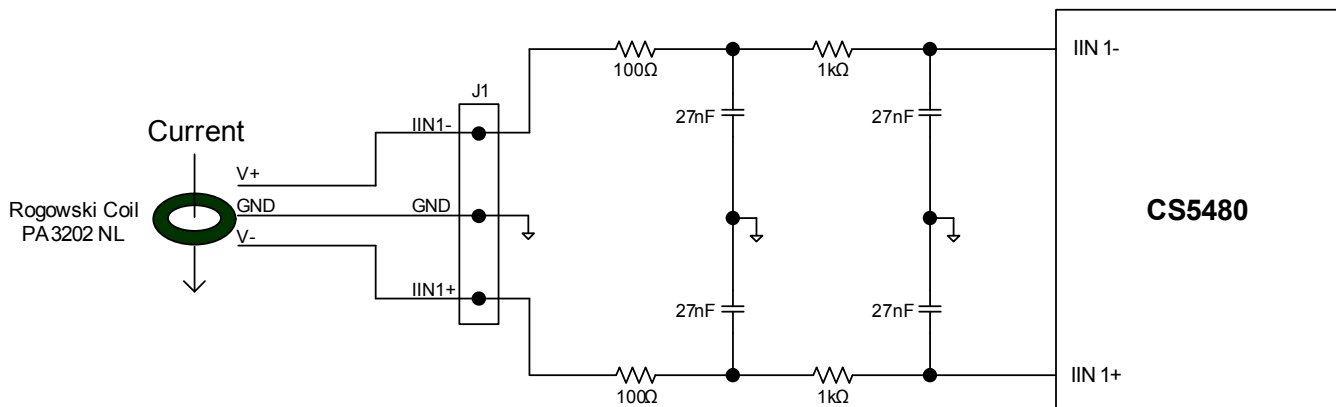

Figure 3. Typical Connections Between a Rogowski Coil and the CS5480

### 3.2 PGA Selection on the Current Channel

The CS5480 current channel incorporates a programmable gain amplifier (PGA) with two selectable input gains. The *Config0* register bits I1PGA[1:0] select either 10x or 50x gain for the current channel. The two PGA settings dictate the maximum input voltage that can be applied to the IIN± inputs.

CS5480 I-channel PGA	Maximum Input Voltage
10x	167mV <sub>RMS</sub>
50x	35mV <sub>RMS</sub>

Table 2. PGA Settings

The Rogowski coil output voltage produced with the maximum AC line current ( $I_{max}$ ) should not exceed the maximum input voltages listed in Table 2. Some margin should be considered according design requirements.

### 3.3 Filter Selection

The CS5480 high-pass filter (HPF) and integrator are set using the *Config2* register. To support a Rogowski coil, HPF must be enabled on the voltage channel and the integrator must be enabled on the current channel.

### 3.4 Calibration and Compensation

To compensate for the tolerances and variations in components and to remove the residual offset and noise in the system, a gain calibration, phase compensation, AC offset calibration, and power offset correction should be performed. For more information, see the CS5480 data sheet, entitled *Three Channel Energy Measurement IC*, for details regarding the calibration and compensations process.

## 4. Measurement Accuracy Results with Rogowski Coils

The CS5480 load performance (measurement accuracy under different load conditions) has been tested with three different types of Rogowski coil. The active and reactive energy load performance is tested with a single energy pulse. The meter constant is set at 2000 impulses per kWh, or 2000 impulses per kVarh. The  $I_{RMS}$  load performance is calculated based on CS5480  $I_{RMS}$  register values. All of the tests were conducted at room temperature and with  $U_n = 240V$  and line frequency of 50Hz.

## 4.1 Load Performance with Rogowski Coil PA3202NL

### 4.1.1 Active Energy Load Performance

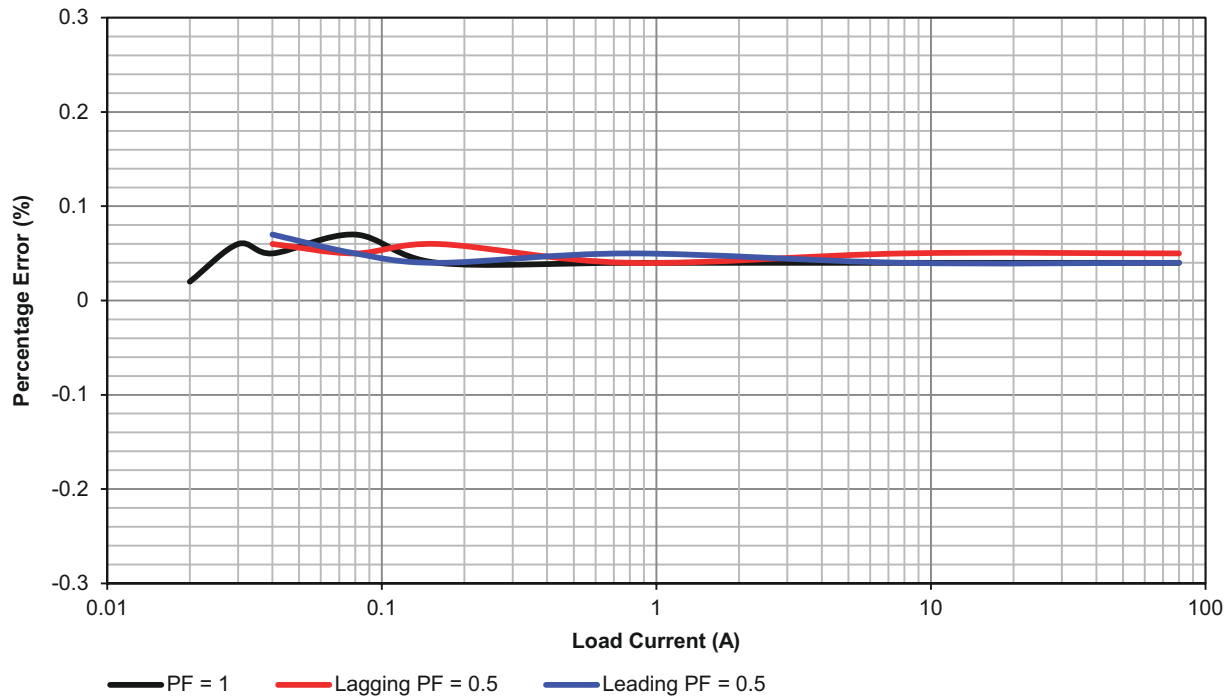

**Figure 4. Active Energy Load Performance**

Power Factor	Load Current (A)	Current Dynamic Range (x:1)	Error
PF = 1	80	1	0.04%
	8	10	0.04%
	0.8	100	0.04%
	0.16	500	0.04%
	0.08	1000	0.07%
	0.04	2000	0.05%
	0.03	3333	0.06%
	0.02	4000	0.02%
Lagging PF = 0.5	80	1	0.05%
	8	10	0.05%
	0.8	100	0.04%
	0.16	500	0.06%
	0.08	1000	0.05%
	0.04	2000	0.06%
Leading PF = 0.5	80	1	0.04%
	8	10	0.04%
	0.8	100	0.05%
	0.16	500	0.04%
	0.08	1000	0.05%
	0.04	2000	0.07%

**Table 3. Active Energy Load Performance**

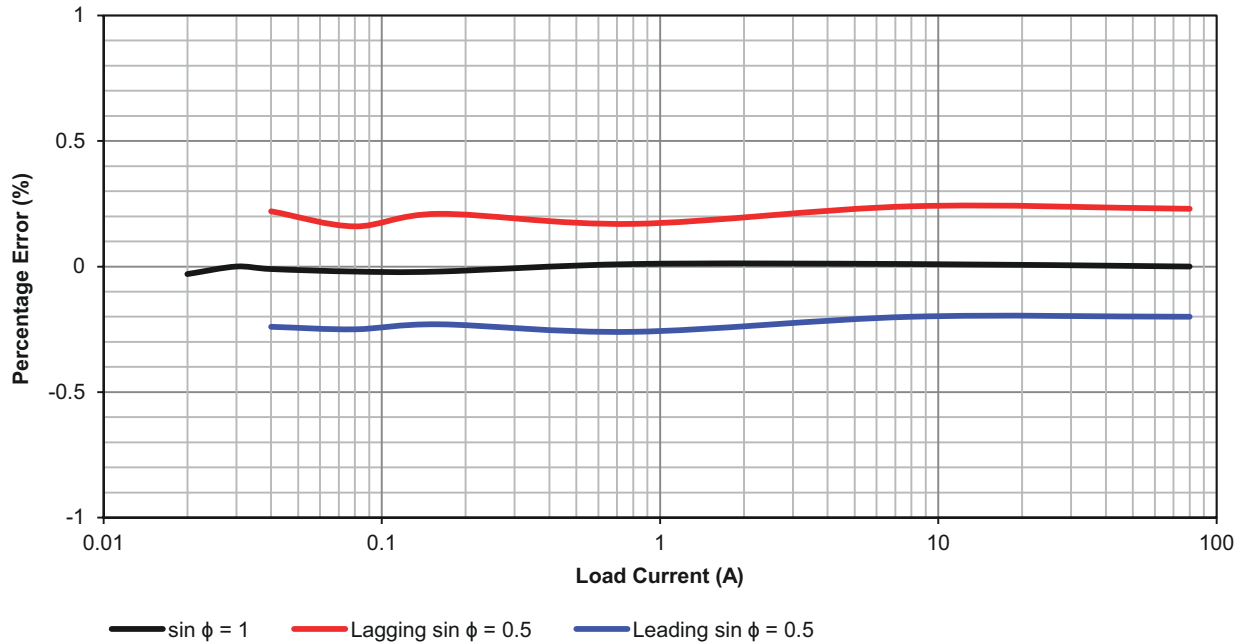
**4.1.2 Reactive Energy Load Performance**

**Figure 5. Reactive Energy Load Performance**

Power Factor	Load Current (A)	Current Dynamic Range (x:1)	Error
$\sin \phi = 1$	80	1	0.00%
	8	10	0.01%
	0.8	100	0.01%
	0.16	500	-0.02%
	0.08	1000	-0.02%
	0.04	2000	-0.01%
	0.03	3333	0.00%
	0.02	4000	-0.03%
Lagging $\sin \phi = 0.5$	80	1	0.23%
	8	10	0.24%
	0.8	100	0.17%
	0.16	500	0.21%
	0.08	1000	0.16%
	0.04	2000	0.22%
Leading $\sin \phi = 0.5$	80	1	-0.20%
	8	10	-0.20%
	0.8	100	-0.26%
	0.16	500	-0.23%
	0.08	1000	-0.25%
	0.04	2000	-0.24%

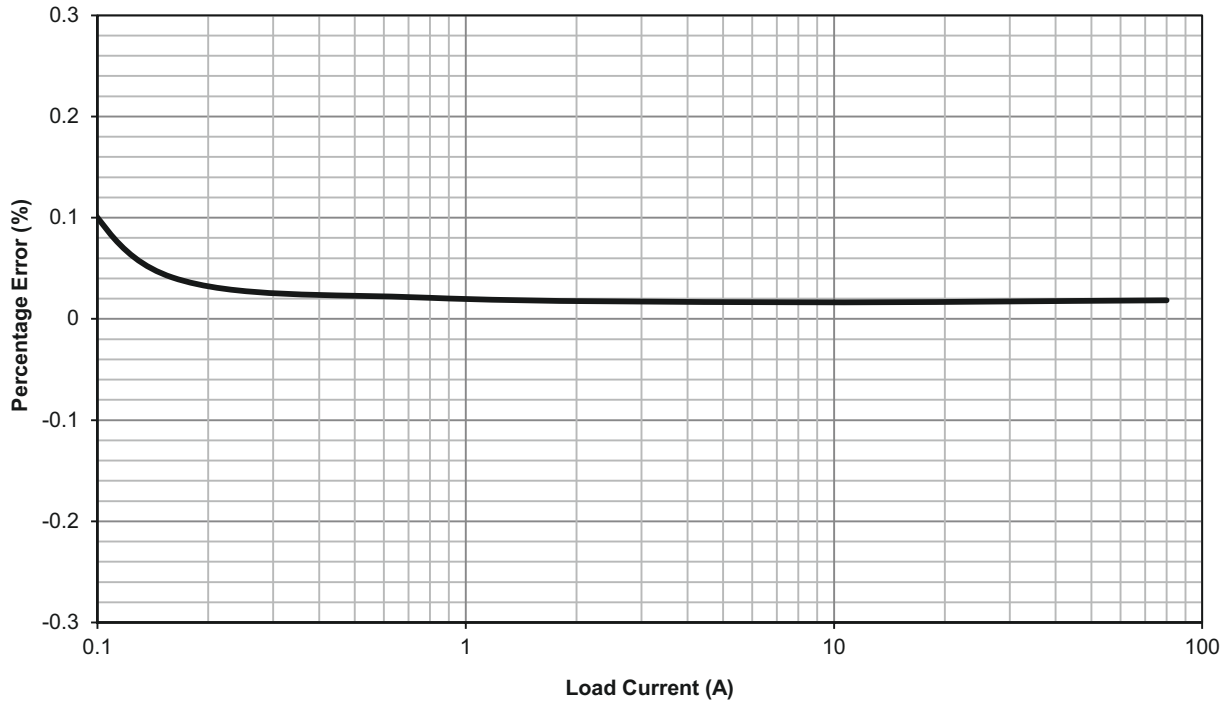
**Table 4. Reactive Energy Load Performance**

**4.1.3  $I_{RMS}$  Load Performance**

**Figure 6.  $I_{RMS}$  Load Performance**

Load Current (A)	Current Dynamic Range (x:1)	$I_{RMS}$ Register Value (10-Second Average)	$I_{RMS}$ Error
80	1	0.60011034	0.02%
8	10	0.060009873	0.02%
0.8	100	0.006001252	0.02%
0.16	500	0.001200491	0.04%
0.08	1000	0.000600857	0.14%

**Table 5.  $I_{RMS}$  Load Performance**

## 4.2 Load Performance with Rogowski Coil TR9L

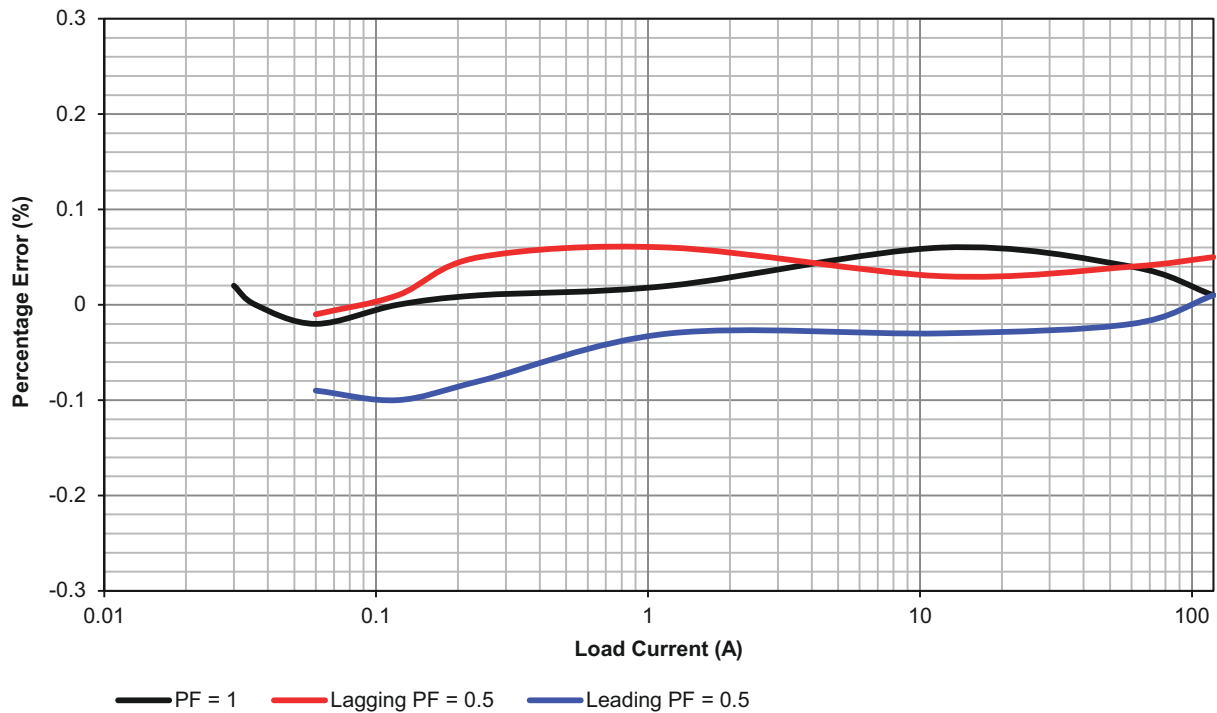
### 4.2.1 Active Energy Load Performance

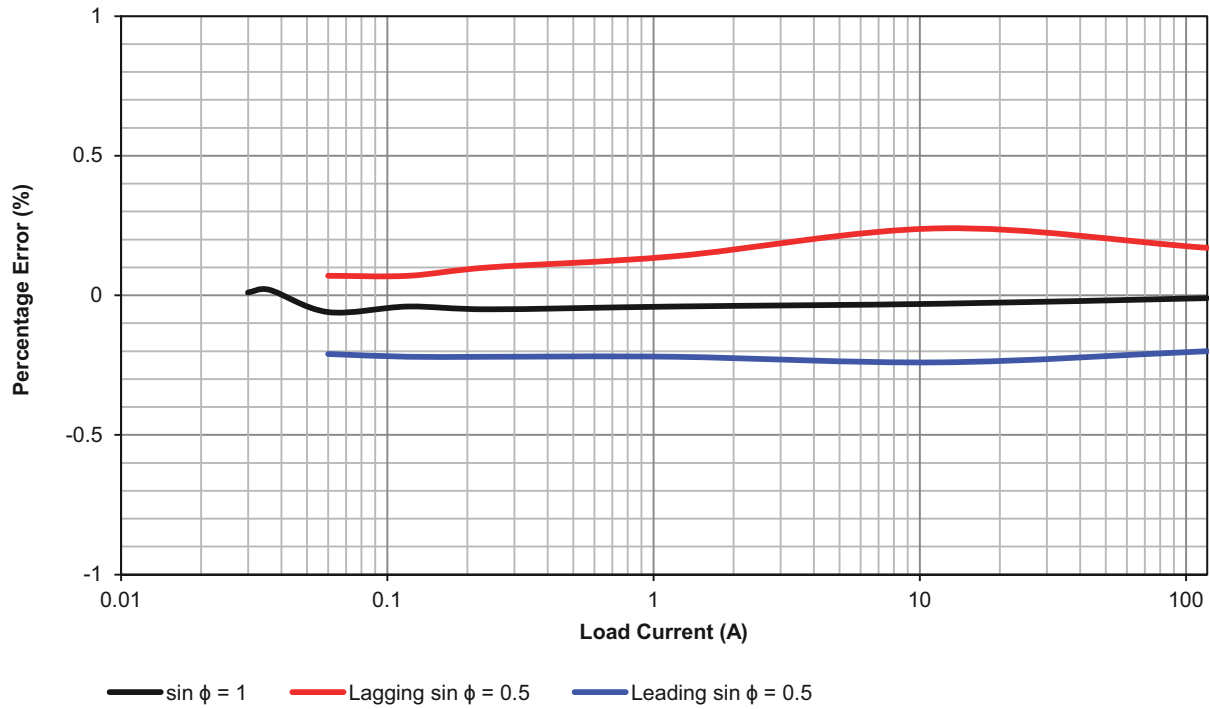

**Figure 7. Active Energy Load Performance**

Power Factor	Load Current (A)	Current Dynamic Range (x:1)	Error
PF = 1	120	1	0.01%
	60	2	0.04%
	12	10	0.06%
	1.2	100	0.02%
	0.24	500	0.01%
	0.12	1000	0.00%
	0.06	2000	-0.02%
	0.036	3333	0.00%
Lagging PF = 0.5	120	1	0.05%
	60	2	0.04%
	12	10	0.03%
	1.2	100	-0.06%
	0.24	500	0.05%
	0.12	1000	0.01%
	0.06	2000	-0.01%
	0.03	4000	0.02%
Leading PF = 0.5	120	1	0.01%
	60	2	-0.02%
	12	10	-0.03%
	1.2	100	-0.03%
	0.06	2000	-0.09%

**Table 6. Active Energy Load Performance**



**4.2.2 Reactive Energy Load Performance**

**Figure 8. Reactive Energy Load Performance**

Power Factor	Load Current (A)	Current Dynamic Range (x:1)	Error
$\sin \phi = 1$	120	1	-0.01%
	12	10	-0.03%
	1.2	100	-0.04%
	0.24	500	-0.05%
	0.12	1000	-0.04%
	0.06	2000	0.06%
	0.036	3333	0.02%
	0.03	4000	0.01%
Lagging $\sin \phi = 0.5$	120	1	0.17%
	12	10	0.24%
	1.2	100	0.14%
	0.24	500	0.10%
	0.12	1000	0.07%
	0.06	2000	0.07%
Leading $\sin \phi = 0.5$	120	1	-0.20%
	12	10	0.24%
	1.2	100	-0.22%
	0.24	500	-0.22%
	0.12	1000	-0.22%
	0.06	2000	-0.21%

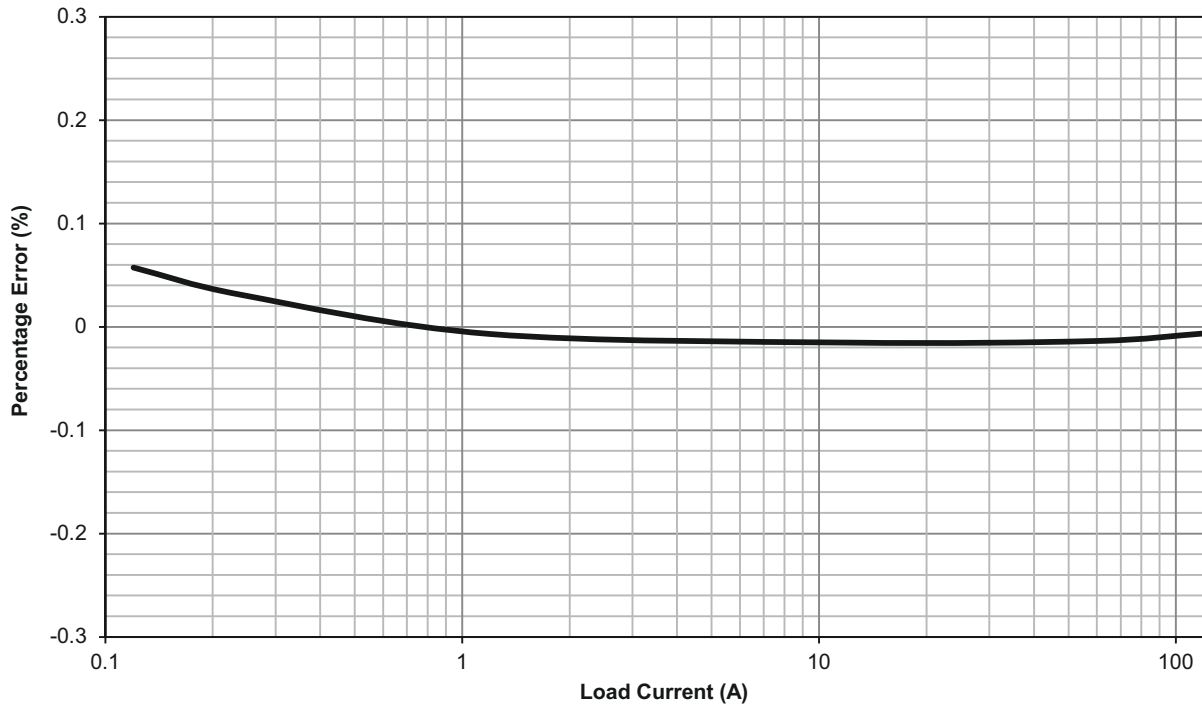
**Table 7. Reactive Energy Load Performance**

**4.2.3  $I_{RMS}$  Load Performance**

**Figure 9.  $I_{RMS}$  Load Performance**

Load Current (A)	Current Dynamic Range (x:1)	$I_{RMS}$ Register Value (10-Second Average)	$I_{RMS}$ Error
120	1	0.599961683	-0.01%
60	2	0.299958968	-0.01%
12	10	0.059990853	-0.02%
1.2	100	0.005999583	-0.01%
0.24	500	0.001200372	0.03%
0.12	1000	0.000600344	0.06%

**Table 8.  $I_{RMS}$  Load Performance**

### 4.3 Load Performance with Sentec

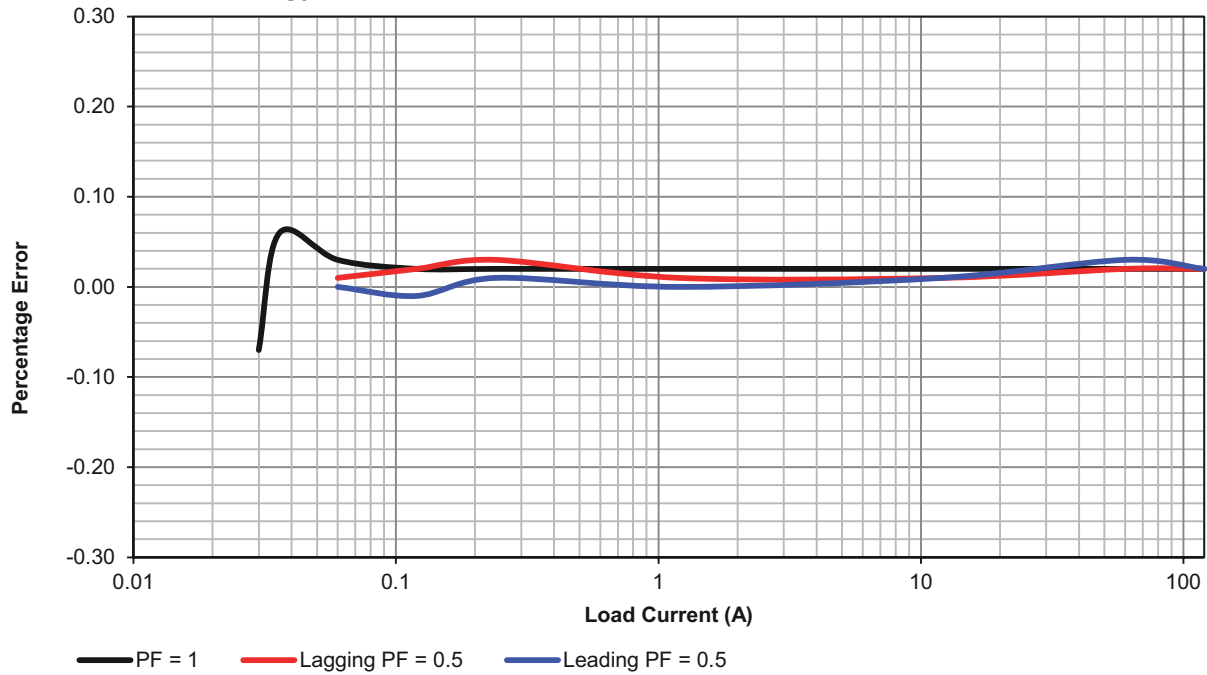
#### 4.3.1 Active Energy Load Performance



**Figure 10. Active Energy Load Performance**

Power Factor	Load Current (A)	Current Dynamic Range (x:1)	Error
PF = 1	120	1	0.02%
	60	2	0.02%
	12	10	0.02%
	1.2	100	0.02%
	0.24	500	0.02%
	0.12	1000	0.03%
	0.06	2000	0.03%
	0.036	3333	0.06%
Lagging PF = 0.5	120	1	0.02%
	60	2	0.02%
	12	10	0.01%
	1.2	100	0.01%
	0.24	500	0.03%
	0.12	1000	0.02%
	0.06	2000	0.01%
Leading PF = 0.5	120	1	0.02%
	60	2	0.03%
	12	10	0.01%
	1.2	100	0.00%
	0.24	500	0.01%
	0.12	1000	-0.01%
	0.06	2000	0.00%

**Table 9. Active Energy Load Performance**

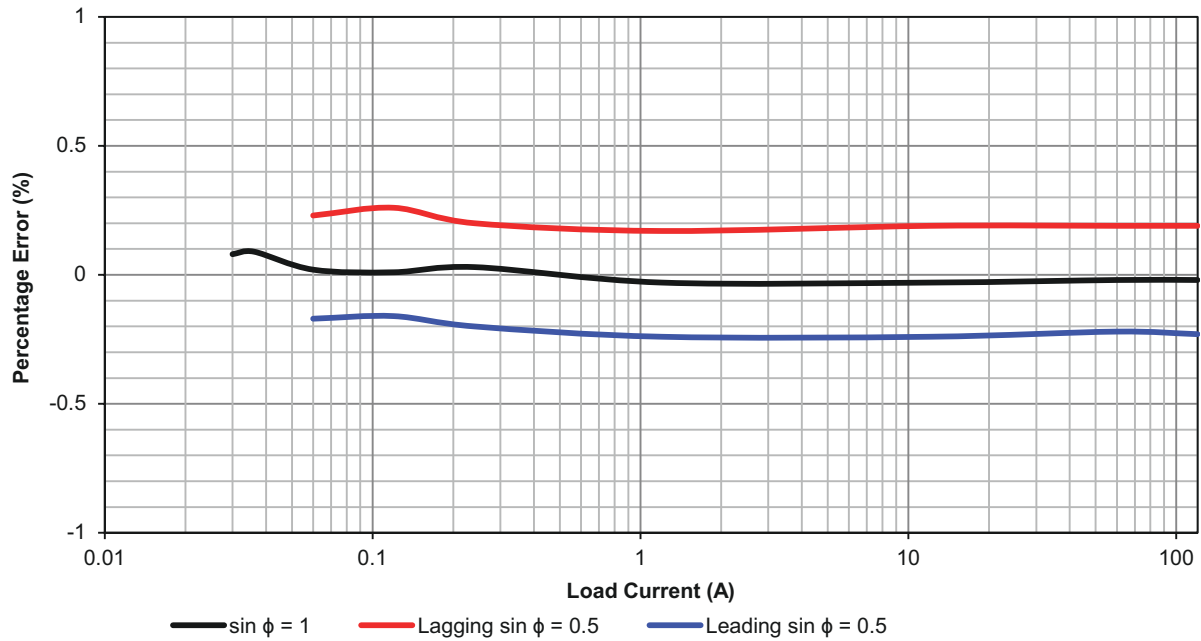
**4.3.2 Reactive Energy Load Performance**

**Figure 11. Reactive Energy Load Performance**

Power Factor	Load Current (A)	Current Dynamic Range (x:1)	Error
$\sin \phi = 1$	120	1	-0.02%
	60	2	-0.02%
	12	10	-0.03%
	1.2	100	-0.03%
	0.24	500	0.03%
	0.12	1000	0.01%
	0.06	2000	0.02%
	0.036	3333	0.09%
Lagging $\phi = 0.5$	120	1	0.19%
	60	2	0.19%
	12	10	0.19%
	1.2	100	0.17%
	0.24	500	0.20%
	0.12	1000	0.26%
	0.06	2000	0.23%
	Leading $\phi = 0.5$	120	1
60		2	-0.22%
12		10	-0.24%
1.2		100	-0.24%
0.24		500	-0.2%
0.12		1000	-0.16%
0.06		2000	-0.17%

**Table 10. Reactive Energy Load Performance**

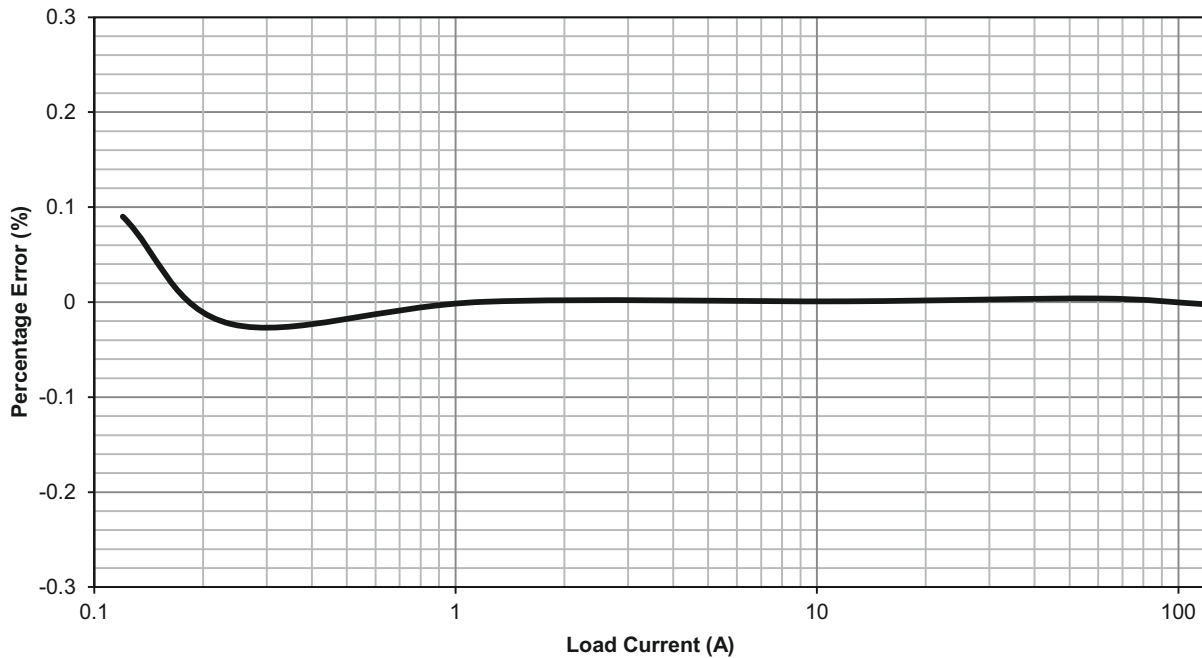
### 4.3.3 $I_{RMS}$ Load Performance



**Figure 12.  $I_{RMS}$  Load Performance**

Load Current (A)	Current Dynamic Range (x:1)	$I_{RMS}$ Register Value (10-Second Average)	$I_{RMS}$ Error
120	1	0.599985965	0.00%
60	2	0.300011613	0.00%
12	10	0.06000053	0.00%
1.2	100	0.006000024	0.00%
0.24	500	0.001199722	-0.02%
0.12	1000	0.000600541	0.09%

**Table 11.  $I_{RMS}$  Load Performance**

## 5. Summary

The CS5480 energy measurement IC supports Rogowski coils using digital integrators. With the exception of two single-pole RC filters, no other external components are required. With on-chip digital calibration and compensation algorithms, the CS5480 can achieve 0.1% energy measurement accuracy over 4000:1 dynamic range.

## Revision History

Revision	Date	Changes
REV1	MAR 2012	Initial Release.

## Contacting Cirrus Logic Support

For all product questions and inquiries contact a Cirrus Logic Sales Representative. To find one nearest you go to <http://www.cirrus.com>

### IMPORTANT NOTICE

Cirrus Logic, Inc. and its subsidiaries ("Cirrus") believe that the information contained in this document is accurate and reliable. However, the information is subject to change without notice and is provided "AS IS" without warranty of any kind (express or implied). Customers are advised to obtain the latest version of relevant information to verify, before placing orders, that information being relied on is current and complete. All products are sold subject to the terms and conditions of sale supplied at the time of order acknowledgment, including those pertaining to warranty, indemnification, and limitation of liability. No responsibility is assumed by Cirrus for the use of this information, including use of this information as the basis for manufacture or sale of any items, or for infringement of patents or other rights of third parties. This document is the property of Cirrus and by furnishing this information, Cirrus grants no license, express or implied under any patents, mask work rights, copyrights, trademarks, trade secrets or other intellectual property rights. Cirrus owns the copyrights associated with the information contained herein and gives consent for copies to be made of the information only for use within your organization with respect to Cirrus integrated circuits or other products of Cirrus. This consent does not extend to other copying such as copying for general distribution, advertising or promotional purposes, or for creating any work for resale.

CERTAIN APPLICATIONS USING SEMICONDUCTOR PRODUCTS MAY INVOLVE POTENTIAL RISKS OF DEATH, PERSONAL INJURY, OR SEVERE PROPERTY OR ENVIRONMENTAL DAMAGE ("CRITICAL APPLICATIONS"). CIRRUS PRODUCTS ARE NOT DESIGNED, AUTHORIZED OR WARRANTED FOR USE IN PRODUCTS SURGICALLY IMPLANTED INTO THE BODY, AUTOMOTIVE SAFETY OR SECURITY DEVICES, LIFE SUPPORT PRODUCTS OR OTHER CRITICAL APPLICATIONS. INCLUSION OF CIRRUS PRODUCTS IN SUCH APPLICATIONS IS UNDERSTOOD TO BE FULLY AT THE CUSTOMER'S RISK AND CIRRUS DISCLAIMS AND MAKES NO WARRANTY, EXPRESS, STATUTORY OR IMPLIED, INCLUDING THE IMPLIED WARRANTIES OF MERCHANTABILITY AND FITNESS FOR PARTICULAR PURPOSE, WITH REGARD TO ANY CIRRUS PRODUCT THAT IS USED IN SUCH A MANNER. IF THE CUSTOMER OR CUSTOMER'S CUSTOMER USES OR PERMITS THE USE OF CIRRUS PRODUCTS IN CRITICAL APPLICATIONS, CUSTOMER AGREES, BY SUCH USE, TO FULLY INDEMNIFY CIRRUS, ITS OFFICERS, DIRECTORS, EMPLOYEES, DISTRIBUTORS AND OTHER AGENTS FROM ANY AND ALL LIABILITY, INCLUDING ATTORNEYS' FEES AND COSTS, THAT MAY RESULT FROM OR ARISE IN CONNECTION WITH THESE USES.

Cirrus Logic, Cirrus, the Cirrus Logic logo designs, EXL Core, and the EXL Core logo design are trademarks of Cirrus Logic, Inc. All other brand and product names in this document may be trademarks or service marks of their respective owners.