CS82L46 Equivalent IO Circuits

Introduction

To provide customers with a greater insight into the input and output structures of the CS82L46 Six-Channel AFE with Sensor Timing Generation and LVDS/CMOS Data Output, a table detailing the equivalent on-chip circuit for each input and output of the device is presented.

Table of Contents

1	Equivalent IO Circuits for CS82L46.....	2
2	Revision History.....	4

1 Equivalent IO Circuits for CS82L46

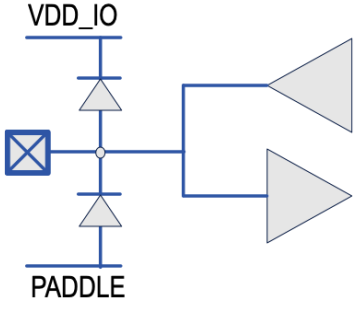
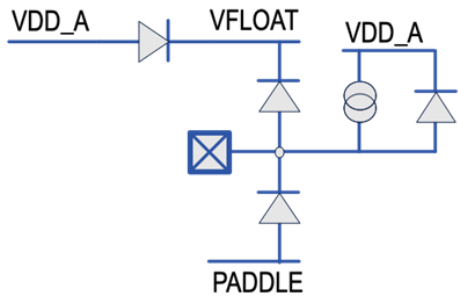
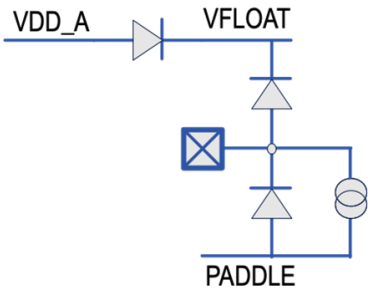
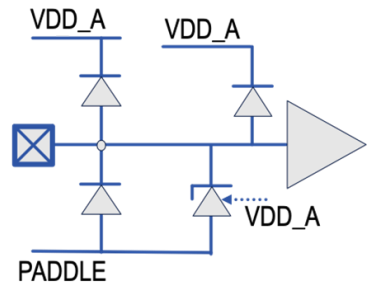
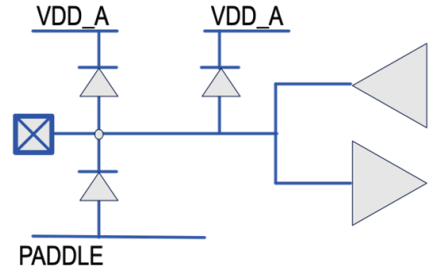
Pin Name	Pin #	Power Supply	I/O	Equivalent Circuit
CLKOUT2/LEDG_EN/LED_START CLKOUT3/LEDB_EN/RSMP_EXT SPI_SDI/I2C_SDA SPI_SDO/I2C_SCL TGSYNC1/VSMP_EXT CLKOUT10 CLKOUT9 CLKOUT8 CLKOUT7 CLKOUT6 CLKOUT5 CLKOUT4 CLKOUT1/LEDR_EN/TGSYNC2	1 2 19 20 40 41 42 43 44 45 46 47 48	VDD_IO	I/O	
ILED_CTRL	3	VDD_A	O	
ILED_R ILED_G ILED_B	4 5 6	VDD_A	I	
IN1 IN2 IN3 IN4 IN5 IN6	7 8 9 10 11 12	VDD_A	I	
VBIAS	13	VDD_A	I/O	

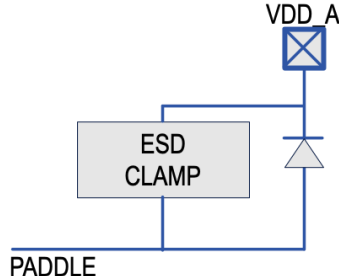
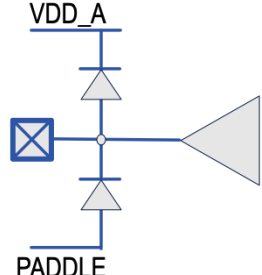
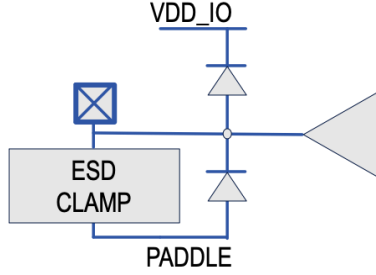
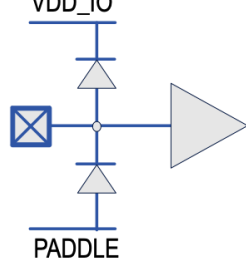
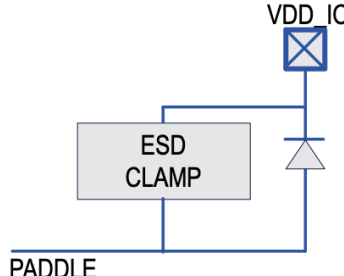
Pin Name	Pin #	Power Supply	I/O	Equivalent Circuit
VDD_A	14	VDD_A	-	
VREF_FILT VLDO1_FILT VLDO3_FILT	15 16 17	VDD_A	O	
VLDO2_FILT	18	VDD_IO	O	
SPI_SCK SPI_CS DSLCT MCLK_EXT_N MCLK_EXT/MCLK_EXT_P	21 22 23 38 39	VDD_IO	I	
VDD_IO VDD_IO	24 37	VDD_IO	-	

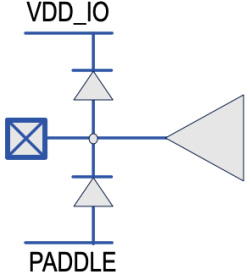
Pin Name	Pin #	Power Supply	I/O	Equivalent Circuit
DOUT5_N/DOUT10	25	VDD_IO	O	
DOUT5_P/DOUT9	26			
DOUT4_N/DOUT8	27			
DOUT4_P/DOUT7	28			
DCLKOUT_N/DCLKOUT2	29			
DCLKOUT_P/DCLKOUT1	30			
DOUT3_N/DOUT6	31			
DOUT3_P/DOUT5	32			
DOUT2_N/DOUT4	33			
DOUT2_P/DOUT3	34			
DOUT1_N/DOUT2	35			
DOUT1_P/DOUT1	36			

2 Revision History

Revision History

Revision	Changes
1.0 JUL 2024	<ul style="list-style-type: none"> Initial version.

Contacting Cirrus Logic Support

For all product questions and inquiries, contact a Cirrus Logic Sales Representative.

To find the one nearest you, go to www.cirrus.com.

IMPORTANT NOTICE

The products and services of Cirrus Logic International (UK) Limited; Cirrus Logic, Inc.; and other companies in the Cirrus Logic group (collectively either “Cirrus Logic” or “Cirrus”) are sold subject to Cirrus Logic’s terms and conditions of sale supplied at the time of order acknowledgment, including those pertaining to warranty, indemnification, and limitation of liability. Software is provided pursuant to applicable license terms. Cirrus Logic reserves the right to make changes to its products and specifications or to discontinue any product or service without notice. Customers should therefore obtain the latest version of relevant information from Cirrus Logic to verify that the information is current and complete. Testing and other quality control techniques are utilized to the extent Cirrus Logic deems necessary. Specific testing of all parameters of each device is not necessarily performed. In order to minimize risks associated with customer applications, the customer must use adequate design and operating safeguards to minimize inherent or procedural hazards. Cirrus Logic is not liable for applications assistance or customer product design. The customer is solely responsible for its overall product design, end-use applications, and system security, including the specific manner in which it uses Cirrus Logic components. Certain uses or product designs may require an intellectual property license from a third party. Features and operations described herein are for illustrative purposes only and do not constitute a suggestion or instruction to adopt a particular product design or a particular mode of operation for a Cirrus Logic component.

CIRRUS LOGIC PRODUCTS ARE NOT DESIGNED, TESTED, INTENDED OR WARRANTED FOR USE (1) WITH OR IN IMPLANTABLE PRODUCTS OR FDA/MHRA CLASS III (OR EQUIVALENT CLASSIFICATION) MEDICAL DEVICES, OR (2) IN ANY PRODUCTS, APPLICATIONS OR SYSTEMS, INCLUDING WITHOUT LIMITATION LIFE-CRITICAL MEDICAL EQUIPMENT OR SAFETY OR SECURITY EQUIPMENT, WHERE MALFUNCTION OF THE PRODUCT COULD CAUSE PERSONAL INJURY, DEATH, SEVERE PROPERTY DAMAGE OR SEVERE ENVIRONMENTAL HARM. INCLUSION OF CIRRUS LOGIC PRODUCTS IN SUCH APPLICATIONS IS UNDERSTOOD TO BE FULLY AT THE CUSTOMER’S RISK AND CIRRUS LOGIC DISCLAIMS AND MAKES NO WARRANTY, EXPRESS, STATUTORY OR IMPLIED, INCLUDING THE IMPLIED WARRANTIES OF MERCHANTABILITY AND FITNESS FOR PARTICULAR PURPOSE, WITH REGARD TO ANY CIRRUS LOGIC PRODUCT THAT IS USED IN SUCH A MANNER. IF THE CUSTOMER OR CUSTOMER’S CUSTOMER USES OR PERMITS THE USE OF CIRRUS LOGIC PRODUCTS IN SUCH A MANNER, CUSTOMER AGREES, BY SUCH USE, TO FULLY INDEMNIFY CIRRUS LOGIC, ITS OFFICERS, DIRECTORS, EMPLOYEES, DISTRIBUTORS AND OTHER AGENTS FROM ANY AND ALL LIABILITY, INCLUDING ATTORNEYS’ FEES AND COSTS, THAT MAY RESULT FROM OR ARISE IN CONNECTION WITH THESE USES.

This document is the property of Cirrus Logic, and you may not use this document in connection with any legal analysis concerning Cirrus Logic products described herein. No license to any technology or intellectual property right of Cirrus Logic or any third party is granted herein, including but not limited to any patent right, copyright, mask work right, or other intellectual property rights. Any provision or publication of any third party’s products or services does not constitute Cirrus Logic’s approval, license, warranty or endorsement thereof. Cirrus Logic gives consent for copies to be made of the information contained herein only for use within your organization with respect to Cirrus Logic integrated circuits or other products of Cirrus Logic, and only if the reproduction is without alteration and is accompanied by all associated copyright, proprietary and other notices and conditions (including this notice). This consent does not extend to other copying such as copying for general distribution, advertising or promotional purposes, or for creating any work for resale. This document and its information is provided “AS IS” without warranty of any kind (express or implied). All statutory warranties and conditions are excluded to the fullest extent possible. No responsibility is assumed by Cirrus Logic for the use of information herein, including use of this information as the basis for manufacture or sale of any items, or for infringement of patents or other rights of third parties. Cirrus Logic, Cirrus, the Cirrus Logic logo design, and SoundClear are among the trademarks of Cirrus Logic. Other brand and product names may be trademarks or service marks of their respective owners.

Copyright © 2024 Cirrus Logic, Inc. and Cirrus Logic International Semiconductor Ltd. All rights reserved.