

Setting the 3D-Stereo Enhancement Block in Wolfson CODECs

INTRODUCTION

The 3D-stereo enhancement filter adjusts the depth or width of the stereo image to create the impression that stereo microphones or speakers are spaced further apart than they are physically. This is often referred to as stereo widening. The 3D-stereo enhancement filter can also be used for beam steering where delays can be used to move the direction of the maximum sensitivity relative to the microphones or speakers. The 3D-stereo enhancement filter includes programmable high-pass or low-pass filtering to limit the 3D effect to specific frequency bands.

This document gives an overview of the 3D-stereo enhancement filter implemented in some of the newer Wolfson audio CODECs. This feature is only available on stereo devices.

BACKGROUND

RECORDING

When recording a stereo image the sound waves from the sound source are recorded by the left and right stereo microphones. If the sound source is directly in front of microphones as shown by Sound Source 1 (90 degree) in Figure 1, there is no delay between the left and right microphones. The maximum delay occurs when the sound source is located on left or right of the microphones as shown in Figure 1 by Sound Source 3 (0 degree) and is equivalent to the distance between left (MICL) and right (MICR) microphones.

If the sound source is located to the side of the microphones, as shown in Figure 1 at Sound Source 2, the sound paths from the sound source to the left and right microphones are different lengths resulting in a delay between the left microphone capturing the sound and the right microphone capturing the sound. As sound travels at a constant rate through air the delay between the left and right signals can be calculated for any given position of the sound source.

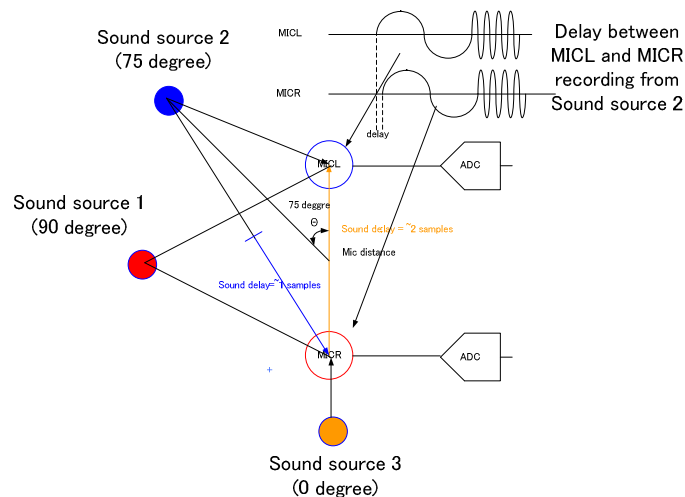

Figure 1 Effect of Angle of Sound Source using Stereo Microphones

The relationship between the angle of the sound source and the delay is shown in Figure 2 for a sampling frequency of 48kHz and microphone spacing of 12.5mm. The delay between the left and right signals depends on the distance between the two microphones and the angle of the sound source to the centre of the left and right microphones.

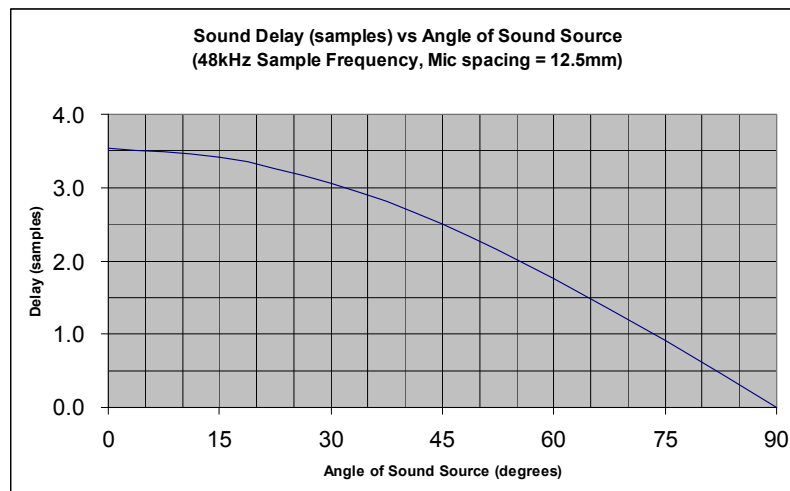

Figure 2 Delay Between Channels vs Angle of Sound Source

PLAYBACK

The same applies when using speakers for playback. If the listener is positioned directly in front of the centre of the two speakers then the listener will hear the sound from both speakers at the same time (in phase). If the listener is positioned nearer the right (or left) speaker the sound from each of the speakers will reach the listener at different times (phase difference) due to the different path lengths from the left and right speakers as shown in Figure 3.

If the right speaker signal is delayed relative to the left speaker then the sound will reach the listener at the same time (in phase) from the left and right speakers and the right speaker will appear to be further away from the listener.

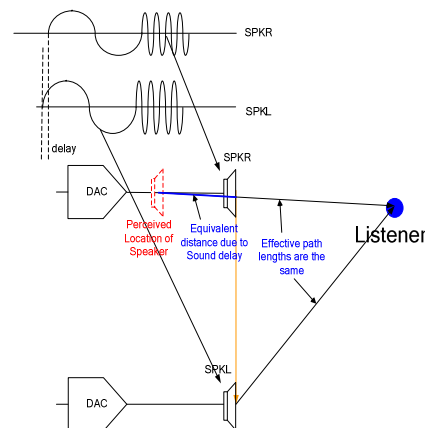

Figure 3 Effect of Delays on Stereo Speakers

3D-STEREO ENHANCEMENT FILTER

If the distance between left and right microphones (or speakers) is small, both microphones record the same sound. This does not give much of a stereo effect. The 3D-stereo enhancement filter uses time delays and controlled cross-talk to adjust the depth or width of the stereo audio. This can be used in the record path to either focus the microphones (Beam Steering) or enhance the separation (Stereo Widening) which can enhance the recording or can be used in the playback path to enhance the separation of stereo speakers (Stereo Widening).

The structure of the 3D-stereo enhancement filter used is shown in Figure 4.

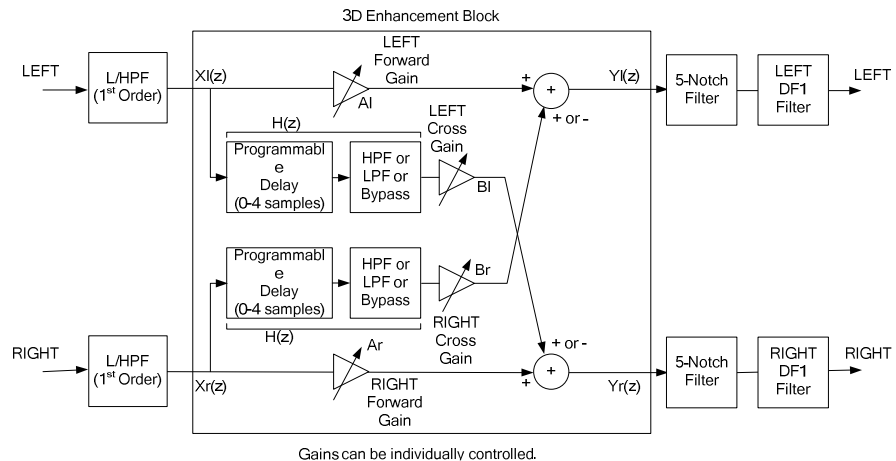

Figure 4 3D-Stereo Enhancement Filter Diagram

The 3D-stereo enhancement filter modifies the signal on left and right channels by adding or subtracting part of the opposite channel signal from the main channel to enhance the microphones or speakers performance. The cross channels can be filtered to remove the high or low frequencies which improves the performance.

CROSS CHANNEL FILTER SELECTION

For stereo widening where the signals are subtracted from each other the low frequency signals will tend to cancel each other out. For example a 100Hz signal has a wavelength of 3.4m. Adding the maximum delay (4T at 48kHz sample frequency) will only change the phase by 0.75 degrees and subtracting these will virtually cancel each other out. For this reason if stereo widening is being used the cross channel filters should be set to HPF the signal.

For beam steering where signals are added together the same effect happens at high frequencies. Adding delays can cause large phase shifts and the signals can cancel each other out. For example at 12kHz the phase shift using the maximum delay (4T at 48kHz sample frequency) is 360 degrees and the signals will cancel each other out when added together. The LPF should be used for beam steering.

RECORDING (STEREO WIDENING)

When using the 3D-stereo enhancement filter in the record path the cross channel signals can be added or subtracted from the forward channel signal. This depends on the effect required. If the cross channel signals are subtracted from the forward signal then the separation of the microphones is perceived to be larger (stereo widening). If the cross channel signals are added to the forward signal then the microphones are more focused (beam steering) and can be used to make the microphones appear more directional.

The transfer function for stereo widening during record is given by:

$$YI(z) = A * XI(z) - B * H(z) * XR(z)$$

$$Yr(z) = A * XR(z) - B * H(z) * XI(z)$$

where

$XI(z)$ = left channel input signal

$XR(z)$ = right channel input signal

A = forward gain

B = cross gain

$H(z)$ = Filter and Delay Transfer Function

$YI(z)$ = left channel output signal

$Yr(z)$ = right channel output signal

For the example if the delay through the left channel cross channel HPF and delay circuit is equivalent to 1 sample period (1T) the sound source will appear to be at approximately the location of the Sound Source 2 in Figure 1.

However the resulting frequency response is not flat. This can be compensated for using the Direct-Form 1 (DF1) filter that is after 3D-stereo enhancement filter. The transfer function for the DF1 filter is given by:

$$H(z) = (c1 + c2 * Z^{-1}) / (1 - c3 * Z^{-1})$$

For this application a low shelf filter should be used as shown in Figure 5.

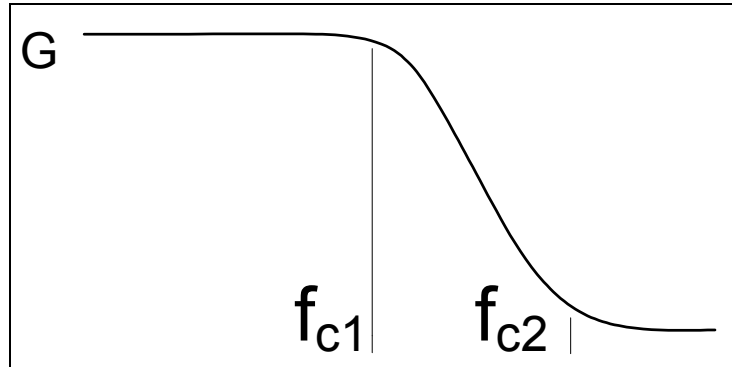

Figure 5 Basic Transfer Function for the DF1 Filter

The overall effect is summarised in Figure 6. The relative effect of each of the blocks is shown giving some indication how the signals are modified and summed together to give the combined effect.

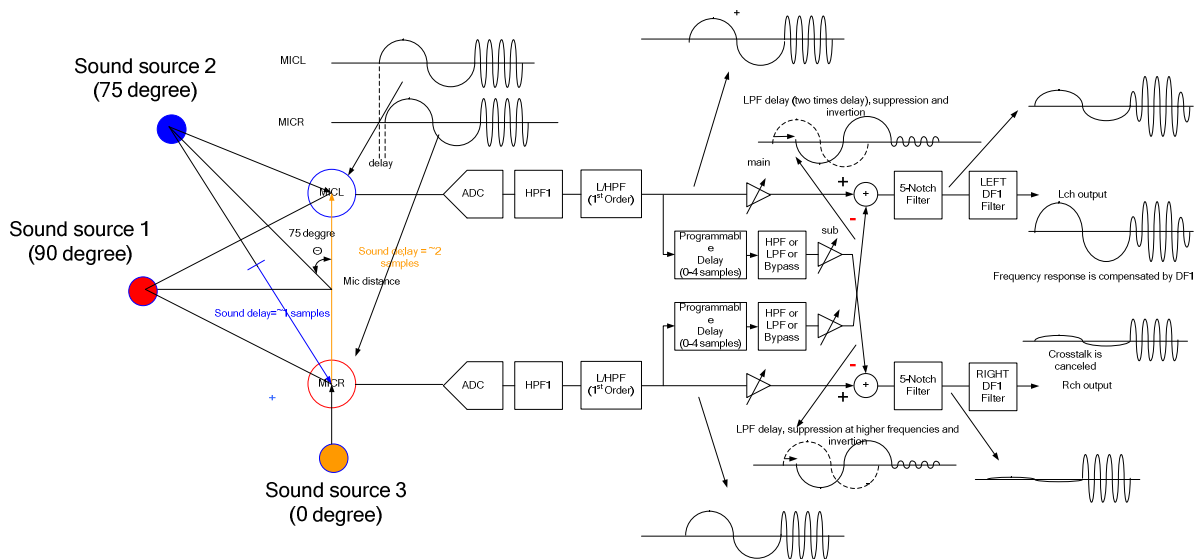

Figure 6 Signals Through the 3D-Stereo Enhancement Filter (Stereo Widening)

Note that in Figure 6 the signals shown after the ADC are digital sampled data but are shown as their equivalent analogue signals for clarity.

RECORDING (BEAM STEERING)

This 3D-stereo enhancement filter can also be used in a microphone array configuration. This allows beam steering to be done to improve the sensitivity of sound sources located in front of the microphone array. In this case the cross channel signals are added to the forward channels. The 1st order filter will be bypassed and some delay will be inserted on sub signal path.

The sensitivity can be increased by up to +6dB compared with one mic because the two microphone signals are added together. The max sensitivity is achieved when the sound path delay is the same as the delay in the cross channel. This mean the sensitivity direction can be controlled by adding delays to point the beam at the sound source. With no delays the microphone beam will have the highest sensitivity at sound source 1 in Figure 7. If a delay of 1T is used the microphone beam can be rotated to have the maximum sensitivity at sound source 2 in Figure 7.

The actual direction for maximum sensitivity also depends on the spacing of the microphones.

The transfer for beam steering is given by:

$$Yl(z) = A * Xl(z) + B * Hl(z) * Xr(z)$$

$$Yr(z) = A * Xr(z) + B * Hr(z) * Xl(z)$$

where

A = forward gain

B = cross gain

Xl(z) = left channel input signal

Xr(z) = right channel input signal

Hl/r(z) = Z^{-1} to Z^{-4} delay

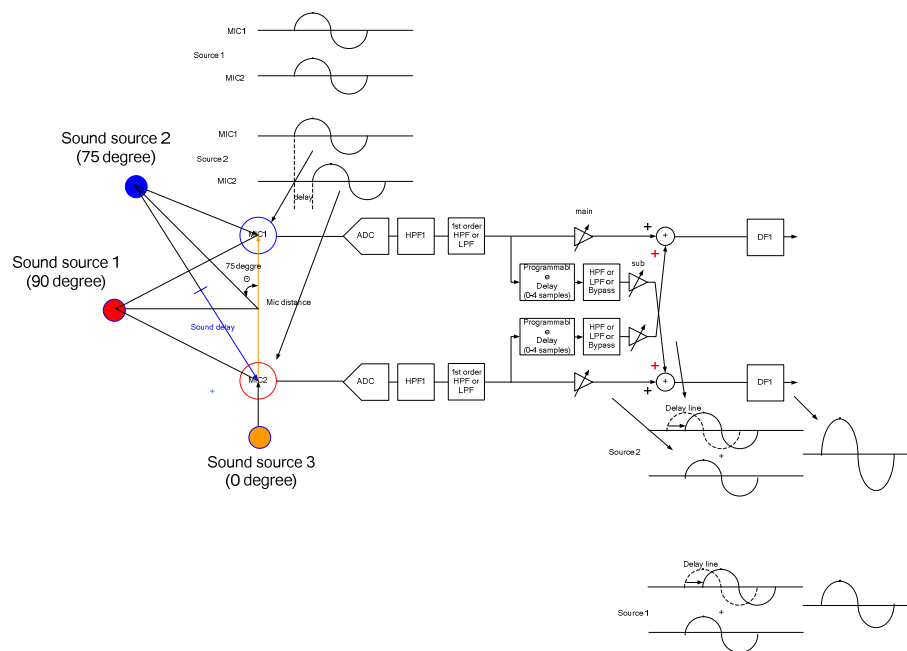

Figure 7 Stereo Microphone Array Configuration (Beam Steering)

PLAYBACK (STEREO WIDENING)

This configuration can be used to widen the effective stereo separation during playback. When the stereo speakers are physically located close together the stereo effect is not very good. By using stereo widening the speakers can be made to sound like they are further apart. This is shown in Figure 9. In this case the cross channels should be subtracted from the forward path.

The transfer for stereo widening is given by:

$$Yl(z) = A * Xl(z) - B * Hr(z) * Xr(z)$$

$$Yr(z) = A * Xr(z) - B * Hl(z) * Xl(z)$$

where

A = forward gain

B = cross gain

Xl(z) = left channel input signal

Xr(z) = right channel input signal

Hl/r(z) = Z^{-1} to Z^{-4} delay

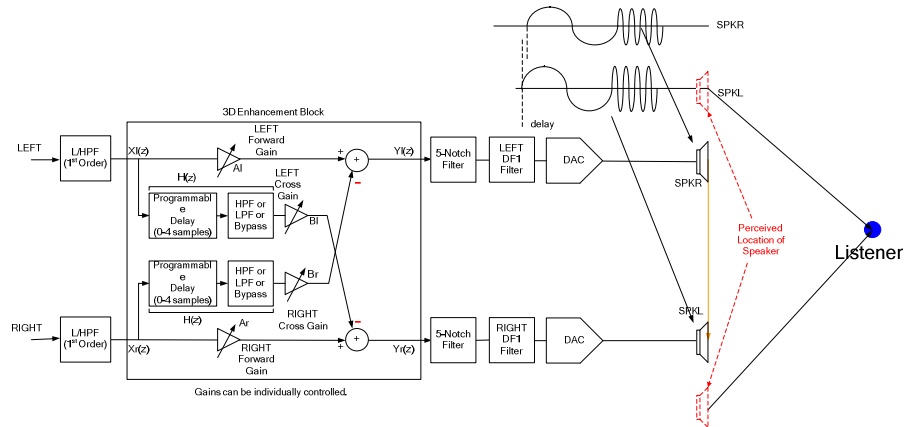

Figure 8 Filter 3D-Stereo Enhancement Filter for Stereo Widening During Playback

The HPF should be used for the stereo widening in playback.

PLAYBACK (BEAM STEERING)

This configuration can be used to make the speakers appear equally spaced during playback. If the listener is not equally spaced from each of the speakers the sound from the closest speaker will be heard first. By delaying this speaker the sound can be made to reach the listener at the same time as the furthest away speaker. This is shown in Figure 9. In this case the cross channels should be added to the forward path.

The transfer for stereo widening is given by:

$$Yl(z) = A * Xl(z) + B * Hr(z) * Xr(z)$$

$$Yr(z) = A * Xr(z) + B * Hl(z) * Xl(z)$$

where

A = forward gain

B = cross gain

Xl(z) = left channel input signal

Xr(z) = right channel input signal

Hl/r(z) = Z⁻¹ to Z⁻⁴ delay

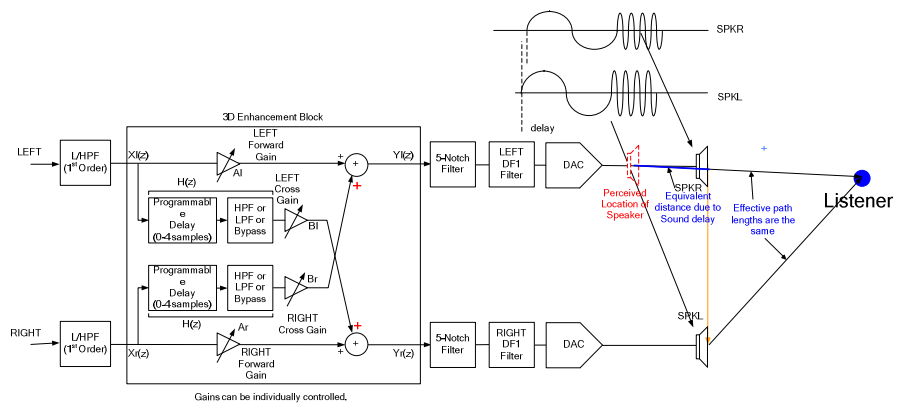

Figure 9 Filter 3D-Stereo Enhancement Filter for Beam Steering During Playback

The LPF should be used for the beam steering.

MONO PLAYBACK

It is possible to set the 3D-stereo enhancement filter to act as a mono mixer that mixes the stereo channels into one mono output channel as shown in Figure 10.

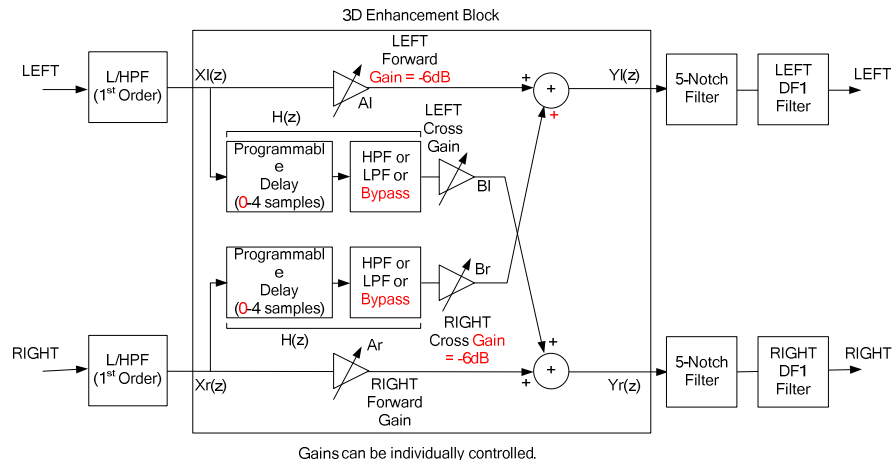

Figure 10 3D-Stereo Enhancement Filter Used for Mono Mixer

The forward and cross channel gains should be set to -6dB. In the cross channel path the HP/LP filter should be set to bypass and the delay set to zero (delay = 0). The sign of the mixer should be set to add the forward and cross channel signals together into a single mono channel.

$$Yl(z) = A * Xl(z) + B * Xr(z)$$

$$Yr(z) = A * Xr(z) + B * Xl(z)$$

where

$Xl(z)$ = left channel input signal

$Xr(z)$ = right channel input signal

A = forward gain = -6dB

B = cross gain = -6dB

$Yl(z)$ = left channel output signal

$Yr(z)$ = right channel output signal

Note that this can be done using either the left or right channel only, or a mono signal can be generated on both channels if both left and right channels are enabled and set up as mono mixers. On some devices there may be a bit that can be set to enable this mode.

REGISTER VALUE CALCULATION

To help set up the 3D-stereo enhancement filter there is a spreadsheet available that will calculate the register values for the chosen setup. This is Applications Note WAN0229 DSP Filter Calculator for WM8948 Series Devices.

SUMMARY/CONCLUSION

This applications note has described the theory behind 3D-stereo enhancement filter and has discussed some of the usage models for the block. The amount of delay and filtering can be varied to get the desired effect. This can be used to make stereo microphones or speakers appear to be spaced further apart than they are physically). Alternatively the 3D-stereo enhancement filter can be used to focus (Beam Steer) stereo microphones such that the optimum direction for recording is pointed towards the sound source. Speakers can be made to appear as if they are equally spaced using the beam steering configuration.

TECHNICAL SUPPORT

If you require more information or require technical support, please contact the nearest Wolfson Microelectronics regional office:

<http://www.wolfsonmicro.com/contact>

or one of our global distributors:

<http://www.wolfsonmicro.com/distribution>

IMPORTANT NOTICE

Wolfson Microelectronics plc ("Wolfson") products and services are sold subject to Wolfson's terms and conditions of sale, delivery and payment supplied at the time of order acknowledgement.

Wolfson warrants performance of its products to the specifications in effect at the date of shipment. Wolfson reserves the right to make changes to its products and specifications or to discontinue any product or service without notice. Customers should therefore obtain the latest version of relevant information from Wolfson to verify that the information is current.

Testing and other quality control techniques are utilised to the extent Wolfson deems necessary to support its warranty. Specific testing of all parameters of each device is not necessarily performed unless required by law or regulation.

In order to minimise risks associated with customer applications, the customer must use adequate design and operating safeguards to minimise inherent or procedural hazards. Wolfson is not liable for applications assistance or customer product design. The customer is solely responsible for its selection and use of Wolfson products. Wolfson is not liable for such selection or use nor for use of any circuitry other than circuitry entirely embodied in a Wolfson product.

Wolfson's products are not intended for use in life support systems, appliances, nuclear systems or systems where malfunction can reasonably be expected to result in personal injury, death or severe property or environmental damage. Any use of products by the customer for such purposes is at the customer's own risk.

Wolfson does not grant any licence (express or implied) under any patent right, copyright, mask work right or other intellectual property right of Wolfson covering or relating to any combination, machine, or process in which its products or services might be or are used. Any provision or publication of any third party's products or services does not constitute Wolfson's approval, licence, warranty or endorsement thereof. Any third party trade marks contained in this document belong to the respective third party owner.

Reproduction of information from Wolfson datasheets is permissible only if reproduction is without alteration and is accompanied by all associated copyright, proprietary and other notices (including this notice) and conditions. Wolfson is not liable for any unauthorised alteration of such information or for any reliance placed thereon.

Any representations made, warranties given, and/or liabilities accepted by any person which differ from those contained in this datasheet or in Wolfson's standard terms and conditions of sale, delivery and payment are made, given and/or accepted at that person's own risk. Wolfson is not liable for any such representations, warranties or liabilities or for any reliance placed thereon by any person.

ADDRESS:

Wolfson Microelectronics plc
Westfield House
26 Westfield Road
Edinburgh
EH11 2QB
United Kingdom

Tel :: +44 (0)131 272 7000

Fax :: +44 (0)131 272 7001