

DOC TYPE:	SCHEMATIC AND LAYOUT
BOARD REFERENCE:	WM8998-6271-CS117-M-REV1.03
BOARD TYPE:	Customer Mini
WOLFSON DEVICE(S):	WM8998
DATE:	February 2014
DOC REVISION:	Rev 1.0

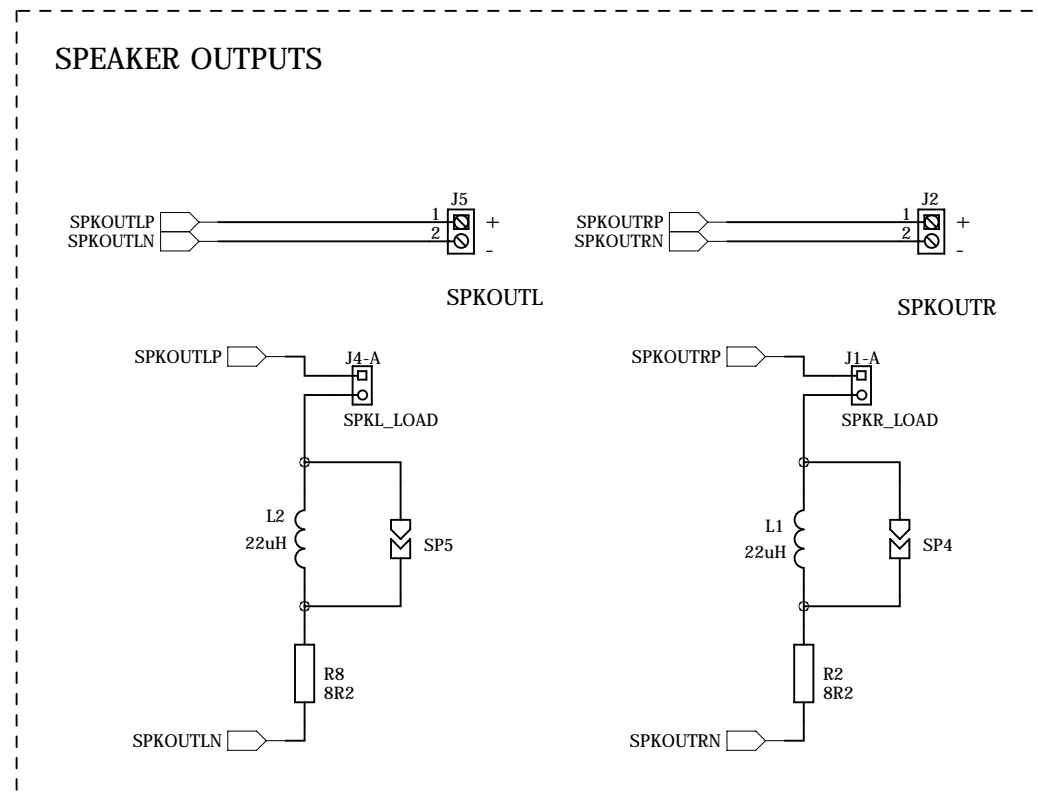

6KHHW \$QDORJXH,2

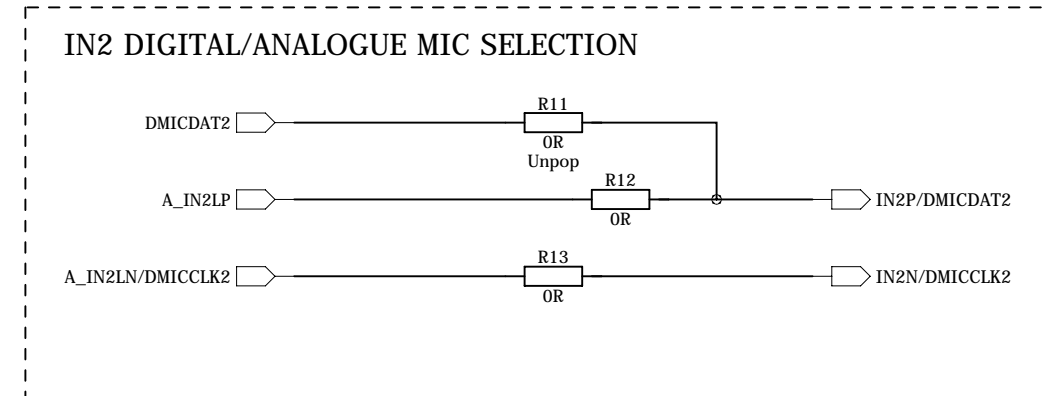
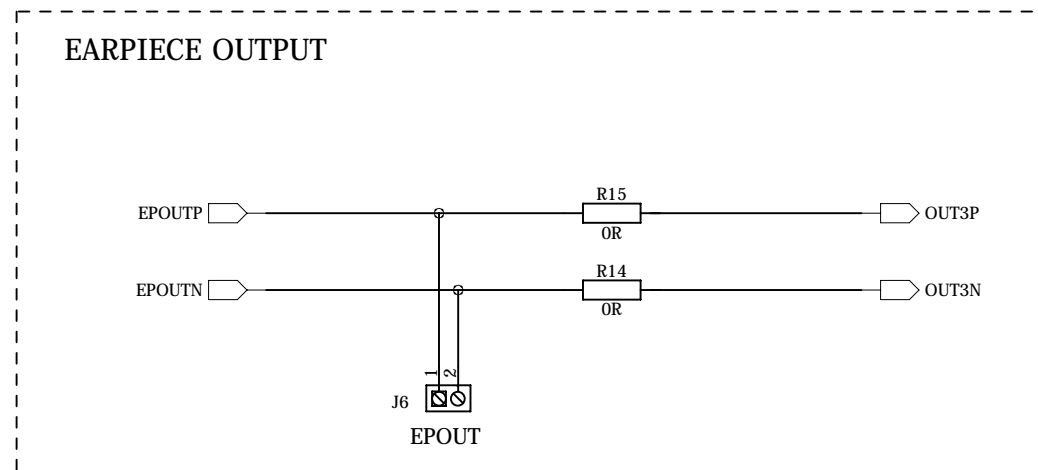
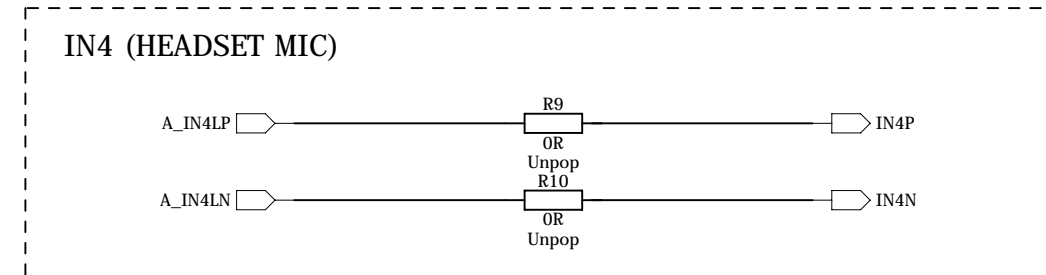
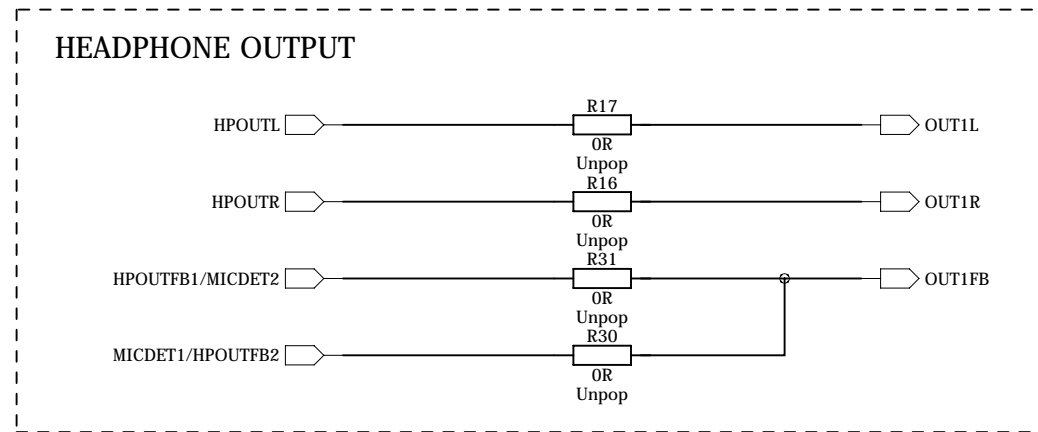