

## High Performance Two-Channel Audio Codec

### Features

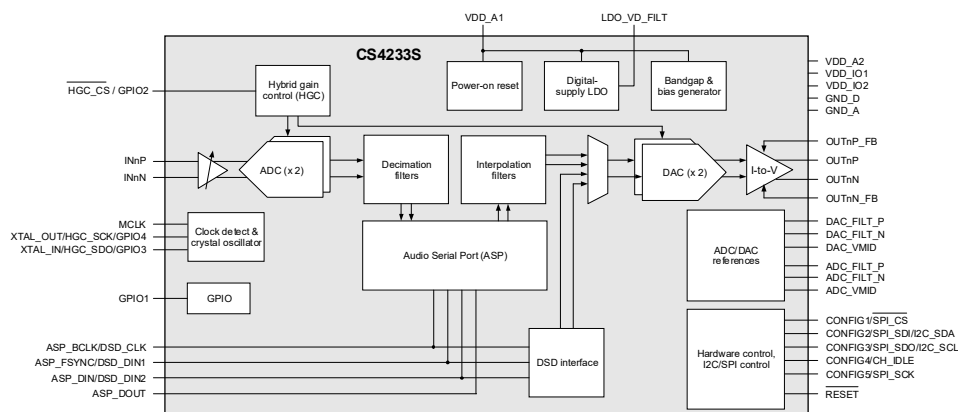
- High performance two-channel codec
  - Differential analog architecture
  - High-resolution 32-bit digital design
  - Low-latency digital filters and digital volume control
- Crystal oscillator interface
- Sample timing alignment across multiple devices
- Hybrid gain control (HGC)
  - Synchronized control of external analog, and internal analog and digital gain
- Virtual passive attenuation device (PAD)
- Clip detection
- Signal activity detection
- Audio serial port (ASP) sample rates up to 384 kHz
  - I<sup>2</sup>S, left-justified, and TDM data formats
- Direct Stream Digital® (DSD) input path supporting direct playback modes at up to 256×Fs oversample rate
- Hardware and software control modes
  - I<sup>2</sup>C control port up to 1 MHz
  - SPI control port up to 24 MHz
  - Hardware control with no host processor required
- Single-supply operation at 3.3 V
  - Support for 1.8 V–3.3 V digital input/output
  - Dual VDD<sub>IO</sub> supplies support independent voltage domains for HGC and control interface
  - 40-pin QFN package

### Specifications

- Advanced multibit sigma-delta ADC
  - 115 dB dynamic range (A-weighted)
  - –105 dB total harmonic distortion + noise (THD+N)
  - 3.9/Fs group delay at 48 kHz sample rate (slow roll-off, minimum phase)
  - 2 V<sub>RMS</sub> differential analog input
  - High-pass filter
- Enhanced oversampling sigma-delta voltage-output DAC
  - 115 dB dynamic range (A-weighted)
  - –105 dB total harmonic distortion + noise (THD+N)
  - 4.6/Fs group delay at 48 kHz sample rate (slow roll-off, minimum phase)
  - 2 V<sub>RMS</sub> full-scale output

### Applications

- A/V receivers
- Digital mixing consoles
- Powered speakers
- Power amplifiers
- High-performance speakers and soundbars
- DAW interfaces
- Musical instruments
- Commercial audio systems



Advanced Product Information

This document contains information for a product under development. Cirrus Logic reserves the right to modify this product without notice.

---

## General Description

The CS4233S is a high-performance, 32-bit resolution, two-channel codec. The CS4233S supports differential analog input/output, and 32-bit digital input/output via the audio serial port (ASP) at sample rates up to 384 kHz. The ADC input path incorporates internal analog gain for signal amplification without additional noise or increased power consumption, minimizing external component requirements. Overall system efficiency and performance is enhanced by delivering superior input-referred noise performance and maintaining signal integrity between different applications. A Direct Stream Digital® (DSD) input path is also available, supporting playback modes at up to 256×Fs oversample rate.

The ADC provides differential architecture, optimized for high performance combined with low power consumption. The CS4233S uses a 5th-order, multibit sigma-delta modulator followed by digital filtering and decimation.

The voltage-output DAC incorporates a proprietary analog FIR architecture to reduce out-of-band noise and minimize the external component requirements. Configurable low-latency digital-interpolation filters are provided. The analog output supports configurable out-of-band filtering, enabling flexible integration and optimal dynamic range for the target application.

The CS4233S can be configured using a control interface supporting I<sup>2</sup>C and SPI modes of operation. The device can also be operated in hardware mode, using external resistors to select the required configuration. Multiple hardware-control options are supported, including system clocking source, ASP format, digital-filter selection, and sample rate.

The low-latency digital filters are optimized for the applicable sample rate. Fast and slow roll-off filters in the ADC path, and fast, slow, and balanced roll-off filters in the DAC path can be combined with minimum or linear phase responses to support the desired signal characteristics. A de-emphasis filter is provided in the DAC output path.

The CS4233S includes a virtual PAD function, to emulate a conventional PAD with minimal impact on the noise floor; this minimizes external component requirements leading to a more compact and efficient design. Zero-cross detection is used to synchronize the internal gain changes with zero points in the input signal, avoiding audible gain-change transients. An automatic PAD response feature is incorporated to prevent clipping of large signals at the ASP output.

The CS4233S supports synchronized control of external analog gain associated with each ADC input and DAC output path. The external gain settings can be configured through either the HGC serial interface or the GPIO pins. Dual VDD<sub>IO</sub> supplies support independent voltage domains for the HGC function and the control interface. Updates to the external and internal gain settings are fully synchronized. A transient-masking function provides additional capability to ensure seamless operation across all signal levels.

The ASP supports operation in I<sup>2</sup>S, left-justified, and TDM data formats. Tristate control of the data-output pin allows multiple devices to operate on a shared bus.

Clocking for the CS4233S is provided by a separate clock source (MCLK) or else from the crystal oscillator. The ADC-sample and DAC-conversion timing is referenced to the ASP data frame, enabling time-aligned operation across multiple devices sharing a common data bus.

The CS4233S can be powered from a single 3.3 V supply. Digital input/output at 1.8 V logic levels is also possible using a separate external supply. The device combines high performance with low power consumption.

The CS4233S is available in a commercial-grade 0.4 mm pitch, 40-pin QFN package for operation from -40°C to +85°C.

See [Section 11](#) for ordering information.

**Table of Contents**

<b>1 Pin Assignments and Descriptions</b> .....	<b>4</b>
1.1 40-Pin QFN (Top View, Through-Package) .....	4
1.2 QFN Pin Descriptions .....	4
1.3 Termination of Unused Pins .....	6
1.4 Electrostatic Discharge (ESD) Protection .....	6
<b>2 Typical Connection Diagrams</b> .....	<b>7</b>
<b>3 Characteristics and Specifications</b> .....	<b>8</b>
Table 3-1. Parameter Definitions .....	8
Table 3-2. Recommended Operating Conditions .....	8
Table 3-3. Absolute Maximum Ratings .....	8
Table 3-4. ADC Path Characteristics .....	9
Table 3-5. DAC Path Characteristics .....	9
Table 3-6. ADC Filter Characteristics .....	10
Table 3-7. ADC High-Pass Filter (HPF) .....	11
Table 3-8. DAC Filter Characteristics .....	11
Table 3-9. DAC High-Pass Filter (HPF) .....	12
Table 3-10. Device Power Consumption .....	12
Table 3-11. Digital Interface Specifications and Characteristics .....	13
Table 3-12. DC Characteristics .....	13
Table 3-13. Switching Specifications—Reset and Clock References .....	14
Table 3-14. Switching Specifications—Audio Serial Port (ASP) .....	14
Table 3-15. Switching Specifications—Direct Stream Digital (DSD) Interface .....	17
Table 3-16. Switching Specifications—I <sup>2</sup> C Control Port .....	18
Table 3-17. Switching Specifications—SPI Control Port .....	19
Table 3-18. Switching Specifications—SPI Controller (Hybrid Gain Control) .....	20
<b>4 Functional Description</b> .....	<b>21</b>
4.1 Device Power and Reset .....	21
4.2 Hardware Configuration .....	21
4.3 Software Configuration .....	23
4.4 System Clocking .....	23
4.5 ADC and Analog Input .....	26
4.6 DAC and Analog Output .....	32
4.7 Hybrid Gain Control .....	33
4.8 Digital Filter Selection .....	41
4.9 Audio Serial Port (ASP) .....	43
4.10 DSD Interface .....	50
4.11 I <sup>2</sup> C/SPI Control Port .....	51
4.12 Interrupts .....	56
4.13 Device ID .....	56
<b>5 Applications</b> .....	<b>57</b>
5.1 Input Buffer Circuit .....	57
5.2 Output Buffer Circuit .....	58
5.3 Crystal Component Selection .....	62
<b>6 Register Quick Reference</b> .....	<b>64</b>
6.1 DEVID .....	64
6.2 CONFIG .....	64
6.3 INPUT_PATH .....	65
6.4 OUTPUT_PATH .....	65
6.5 HGC .....	66
6.6 PIN_CONFIG .....	69
6.7 IRQ_CONFIG .....	69
<b>7 Register Descriptions</b> .....	<b>71</b>
7.1 DEVID .....	71
7.2 CONFIG .....	72
7.3 INPUT_PATH .....	73
7.4 OUTPUT_PATH .....	76
7.5 HGC .....	79
7.6 PIN_CONFIG .....	99
7.7 IRQ_CONFIG .....	99
<b>8 Thermal Characteristic</b> .....	<b>103</b>
<b>9 Package Dimensions</b> .....	<b>103</b>
<b>10 Package Marking</b> .....	<b>104</b>
<b>11 Ordering Information</b> .....	<b>104</b>
<b>12 References</b> .....	<b>104</b>
<b>13 Revision History</b> .....	<b>104</b>

# 1 Pin Assignments and Descriptions

## 1.1 40-Pin QFN (Top View, Through-Package)

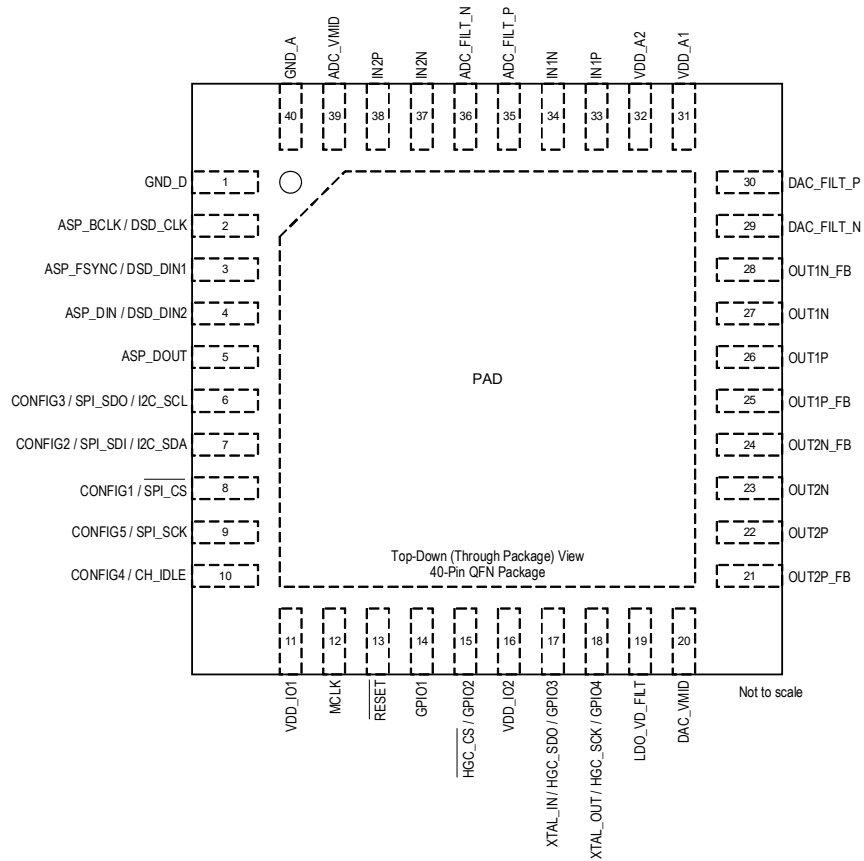


Figure 1-1. QFN 40-Pin Diagram (Top View, Through Package)

## 1.2 QFN Pin Descriptions

Table 1-1. QFN Pin Descriptions

Pin Name	Pin #	Power Supply	I/O	Description
<b>Digital I/O</b>				
ASP_BCLK/DSD_CLK	2	VDD_IO1	I/O	Audio serial port bit clock/DSD clock.
ASP_DIN/DSD_DIN2	4	VDD_IO1	I	Audio serial port data input/DSD data Input 2.
ASP_DOUT	5	VDD_IO1	O	Audio serial port data output.
ASP_FSYNC/DSD_DIN1	3	VDD_IO1	I/O	Audio serial port frame sync/DSD data Input 1.
GPIO1	14	VDD_IO2	I/O	General-purpose input/output.
HGC_CS/GPIO2	15	VDD_IO2	I/O	Hybrid gain control (HGC) chip select/General-purpose input/output.
MCLK	12	VDD_IO1	I/O	Master clock input/output.
RESET	13	VDD_IO1	I	Hardware reset control (active low).
XTAL_IN/HGC_SDO/GPIO3	17	VDD_IO2	I/O	Input for an external crystal/HGC data output/General-purpose input/output.
XTAL_OUT/HGC_SCK/GPIO4	18	VDD_IO2	I/O	Output for an external crystal/HGC clock/General-purpose input/output.

**Table 1-1. QFN Pin Descriptions (Cont.)**

Pin Name	Pin #	Power Supply	I/O	Description
<b>Analog I/O</b>				
ADC_FILT_N	36	VDD_A2	O	ADC external capacitor connection.
ADC_FILT_P	35	VDD_A2	O	
ADC_VMID	39	VDD_A2	O	ADC mid-rail voltage reference output.
CONFIG1/SPI_CS	8	VDD_IO1	I	Hardware control pins.
CONFIG2/SPI_SDI/I2C_SDA	7	VDD_IO1	I/O	In software control mode, CONFIG1–3 and CONFIG5 support the SPI/I2C interface.
CONFIG3/SPI_SDO/I2C_SCL	6	VDD_IO1	I/O	
CONFIG4/CH_IDLE	10	VDD_IO1	I/O	In software control mode, CONFIG1 selects the I2C target address.
CONFIG5/SPI_SCK	9	VDD_IO1	I	In software control mode, CONFIG4 supports Signal Activity Detection.
DAC_FILT_N	29	VDD_A1	O	DAC external capacitor connection.
DAC_FILT_P	30	VDD_A1	O	
DAC_VMID	20	VDD_A1	O	DAC mid-rail voltage reference output.
IN1N	34	VDD_A2	I	Analog Input 1.
IN1P	33	VDD_A2	I	
IN2N	37	VDD_A2	I	Analog Input 2.
IN2P	38	VDD_A2	I	
LDO_VD_FILT	19	VDD_A1	O	LDO_D regulator external capacitor connection.
OUT1N	27	VDD_A1	O	Analog Output 1.
OUT1P	26	VDD_A1	O	
OUT2N	23	VDD_A1	O	Analog Output 2.
OUT2P	22	VDD_A1	O	
OUT1N_FB	28	VDD_A1	O	Analog Output 1 feedback connection.
OUT1P_FB	25	VDD_A1	O	
OUT2N_FB	24	VDD_A1	O	Analog Output 2 feedback connection.
OUT2P_FB	21	VDD_A1	O	
<b>Power Supplies</b>				
VDD_A1	31	—	—	Analog Supply 1.
VDD_A2	32	—	—	Analog Supply 2.
VDD_IO1	11	—	—	Digital I/O Supply 1.
VDD_IO2	16	—	—	Digital I/O Supply 2.
GND_A	40, PAD	—	—	Analog ground 1.
GND_D	1	—	—	Digital ground 1.

1. All ground pins, including the ground paddle, must be tied to a common ground plane directly underneath the CS4233S. It is recommended that each ground pin is connected separately to the ground plane, using multiple vias to connect the ground paddle.

## 1.3 Termination of Unused Pins

Table 1-2 shows the required termination for unused pins (i.e., if the functionality of the pin is not being used). Pins not listed must be connected as shown in the typical connection drawings (see Section 2).

**Table 1-2. Termination of Unused Pins**

Name	Termination if unused
ASP_DOUT	Float
INnX <sup>1</sup>	
MCLK <sup>2</sup>	
ASP_DIN/DSD_DIN2	10 kΩ pull-down to GND
ASP_FSYNC/DSD_IN1	
CONFIG3/SPI_SDO/I2C_SCL	
CONFIG4/CH_IDLE	
CONFIG5/SPI_SCK	
GPIO1	
HGC_CS/GPIO2	
XTAL_IN/HGC_SDO/GPIO3	
XTAL_OUT/HGC_SCK/GPIO4	Connect to OUTnX_FB
OUTnX <sup>3</sup>	
RESET	Connect to VDD_IO1

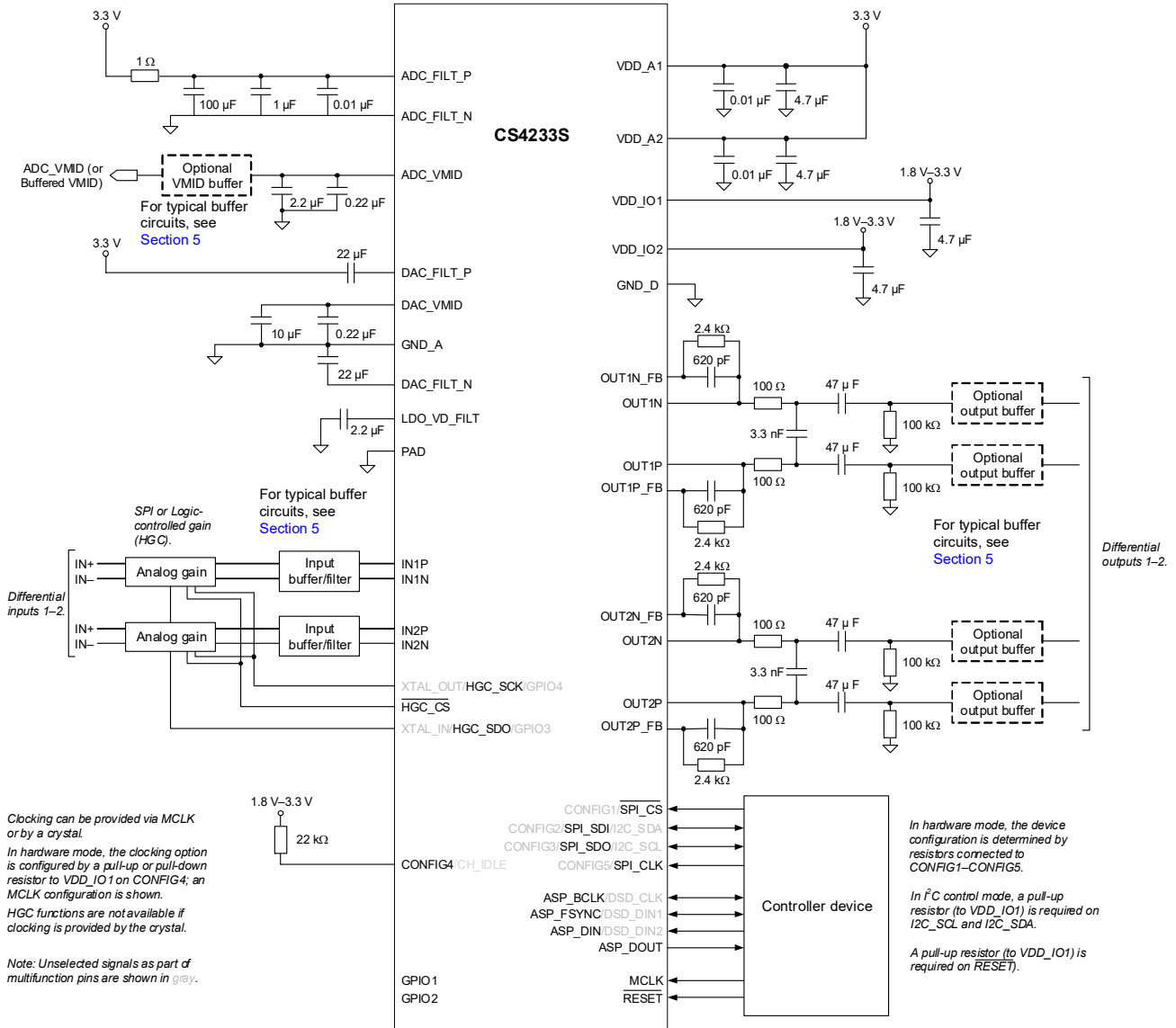
1. See Section 5.1.1 for requirements in case of single-ended input configurations.
2. If the system clock is provided by the crystal oscillator and an MCLK output is not required, MCLK should be left floating.
3. See Section 5.2.3 for requirements in case of single-ended output configurations.

## 1.4 Electrostatic Discharge (ESD) Protection



ESD-sensitive device. The CS4233S is manufactured on a CMOS process. Therefore, it is generically susceptible to damage from excessive static voltages. Proper ESD precautions must be taken while handling and storing this device. This device is qualified to current JEDEC ESD protection standards.

## 2 Typical Connection Diagrams



**Figure 2-1. Typical Connections**

### 3 Characteristics and Specifications

**Note:** Table 3-1 defines parameters as they are characterized in this section. Default register field configurations are used unless specified otherwise in the test conditions.

**Table 3-1. Parameter Definitions**

Parameter	Definition
Channel separation	The difference in level between the active channel (driven to maximum full scale output) and the measured signal level in the idle channel at the test signal frequency. The active channel is configured and supplied with an appropriate input signal to drive a full scale output, with signal measured at the output of the associated idle channel.
Common-mode rejection ratio (CMRR)	The ratio of a specified input signal (applied to both sides of a differential input), relative to the output signal that results from it.
Signal-to-noise ratio	The difference in level between the maximum full-scale output signal and the output with no input signal applied.
Dynamic range	The difference in level between the maximum full-scale output signal and the sum of all harmonic distortion products plus noise with a low-level input signal applied (an input signal level 60 dB below full scale is used).
Power-supply rejection ratio (PSRR)	The ratio of a specified power supply variation relative to the output signal that results from it. PSRR is measured under quiescent signal path conditions.
Total harmonic distortion plus noise (THD+N)	The ratio of the RMS sum of the harmonic distortion products plus noise in the specified bandwidth relative to the RMS amplitude of the fundamental (i.e., test frequency) output.

**Note:** Unless specified otherwise, all performance measurements are for a 10 Hz to 20 kHz bandwidth.

**Table 3-2. Recommended Operating Conditions**

Test conditions (unless specified otherwise): Ground = GND = GND\_A = PAD = GND\_D = 0 V; voltages are with respect to ground.

Parameter		Symbol	Minimum	Maximum	Unit
DC power supply	Analog supply <sup>1</sup>	VDD_A1, VDD_A2	3.13	3.47	V
	Digital I/O supply	VDD_IO1, VDD_IO2	1.71	3.63	V
Supply ramp up/down (all supplies)		t <sub>PWR-UD</sub>	0.01	10	ms
Ambient temperature		Commercial Grade T <sub>A</sub>	-40	85	°C

**Note:** The device is fully functional and meets all parametric specifications in this section if operated within the specified conditions. Functionality and parametric performance is not guaranteed or implied outside of these limits. Operation outside of these limits may adversely affect device reliability.

1. The VDD\_A1 and VDD\_A2 rails should be tied together and powered from a single supply. The associated power domain is referred to as VDD\_A.

**Table 3-3. Absolute Maximum Ratings**

Test conditions (unless specified otherwise): Ground = GND = GND\_A = PAD = GND\_D = 0 V; voltages are with respect to ground.

Parameter		Symbol	Minimum	Maximum	Unit
DC power supply	Analog supply <sup>1</sup>	VDD_A1, VDD_A2	-0.3	4.32	V
	Digital I/O supply	VDD_IO1, VDD_IO2	-0.3	4.32	V
External voltage applied to digital input/output	VDD_IO1 logic pins	V <sub>INDI</sub>	-0.3	VDD_IO1 + 0.3	V
	VDD_IO2 logic pins		-0.3	VDD_IO2 + 0.3	V
External voltage applied to analog inputs		V <sub>INAI</sub>	-0.3	VDD_A + 0.3	V
Input current	digital input/output	I <sub>IN</sub>	—	±10	mA
	analog inputs		—	±10	mA
Ambient operating temperature		T <sub>A</sub>	-40	+115	°C
Junction operating temperature		T <sub>J</sub>	-40	+125	°C
Storage temperature		T <sub>STG</sub>	-65	+150	°C

**Caution:** Stresses beyond “Absolute Maximum Ratings” levels may cause permanent damage to the device. These levels are stress ratings only, and functional operation of the device at these or any other conditions beyond those indicated in Table 3-2 is not implied. Exposure to absolute maximum rating conditions for extended periods may affect device reliability.

1. The VDD\_A1 and VDD\_A2 rails should be tied together and powered from a single supply. The associated power domain is referred to as VDD\_A.

**Table 3-4. ADC Path Characteristics**

Test conditions (unless specified otherwise): External components as shown in Fig. 2-1 incorporating the typical output circuit illustrated in Fig. 5-1; VDD<sub>A</sub> = VDD<sub>IO1</sub> = VDD<sub>IO2</sub> = 3.3 V; Ground = GND = GND<sub>A</sub> = PAD = GND<sub>D</sub> = 0 V; voltages are with respect to ground; T<sub>A</sub> = +25°C; 1 kHz sine wave test signal; F<sub>s</sub> = 48 kHz, 32-bit audio data, MCLK = 24.576 MHz.

Parameter		Min	Typ	Max	Units
Input impedance (INnP to INnN)	internal analog gain = 0 dB	—	12	—	kΩ
	internal analog gain = 6 dB	—	6	—	kΩ
	internal analog gain = 12 dB	—	3	—	kΩ
Full-scale differential input signal level (INnP to INnN) <sup>1</sup>	0 dBFS output	—	2.0	—	V <sub>RMS</sub>
SNR	A-weighted	112	115	—	dB
	unweighted	109	112	—	dB
Dynamic range <sup>2</sup>	A-weighted	—	115	—	dB
	unweighted	—	112	—	dB
THD+N	-1 dBFS output	—	-105	-99	dB
	-20 dBFS output	—	-92	—	dB
	-60 dBFS output	—	-52	—	dB
Input-referred noise (A-weighted)	internal analog gain = 0 dB	—	3.55	4.97	μV <sub>RMS</sub>
	internal analog gain = 6 dB	—	2.51	3.52	μV <sub>RMS</sub>
	internal analog gain = 12 dB	—	1.78	2.49	μV <sub>RMS</sub>
CMRR	100 mV (peak-peak) 1 kHz	—	80	—	dB
Channel separation		—	110	—	dB
Interchannel phase deviation		—	0.03	—	degree
Interchannel gain deviation		—	0.1	—	dB
Gain drift		—	±100	—	ppm/°C
DC offset error	HPF enabled	—	0	—	μV
	HPF disabled	—	100	—	μV
PSRR (VDD <sub>A</sub> )	100 mV (peak-peak) 1 kHz sine wave	—	65	—	dB

1. The full-scale input signal level is also the maximum analog input level, before clipping occurs. A sinusoidal input signal is assumed.

Full-scale input signal level scales with VDD<sub>A</sub>.

2. Dynamic range is derived by measuring the performance including the input buffer, and then deducting the contribution from the input buffer.

**Table 3-5. DAC Path Characteristics**

Test conditions (unless specified otherwise): External components as shown in Fig. 2-1;

VDD<sub>A</sub> = VDD<sub>IO1</sub> = VDD<sub>IO2</sub> = 3.3 V; Ground = GND = GND<sub>A</sub> = PAD = GND<sub>D</sub> = 0 V; voltages are with respect to ground; T<sub>A</sub> = +25°C; 1 kHz sine wave test signal; F<sub>s</sub> = 48 kHz, 32-bit audio data, MCLK = 24.576 MHz.

Parameter		Min	Typ	Max	Units
Full scale differential output signal level (OUTnP to OUTnN)	0 dBFS input	—	2.00	—	V <sub>RMS</sub>
Dynamic range	A-weighted	112	115	—	dB
	unweighted	109	112	—	dB
THD+N	0 dBFS input	—	-105	-99	dB
	-20 dBFS input	—	-92	—	dB
	-60 dBFS input	—	-52	—	dB
Idle channel noise	A-weighted	—	3.55	—	μV <sub>RMS</sub>
Channel separation	1 kHz	—	110	—	dB
	20 kHz	—	100	—	dB
DC offset error		—	±0.5	—	mV
PSRR (VDD <sub>A</sub> )	100 mV (peak-peak) 1 kHz sine wave	—	75	—	dB
Load resistance		3	—	—	kΩ
Load capacitance		—	—	100	pF

**Table 3-6. ADC Filter Characteristics**

Test conditions (unless specified otherwise): VDD\_A = VDD\_IO1 = VDD\_IO2 = 3.3 V; Ground = GND = GND\_A = PAD = GND\_D = 0 V; voltages are with respect to ground; T<sub>A</sub> = +25°C; 1 kHz sine wave test signal, 32-bit audio data.

		Parameter	Min	Typ	Max	Units	
Fs = 16 kHz	Fast roll-off	Passband	to -3 dB corner	—	—	0.47	Fs
		Passband ripple	f ≤ 0.45 Fs	-0.092	—	0.092	dB
		Stopband attenuation	f ≥ 0.55 Fs	98	—	—	dB
		Group delay <sup>1</sup>	linear phase minimum phase	— —	20.5/Fs 4.1/Fs	— —	s s
Fs = 32 kHz	Fast roll-off	Passband	to -3 dB corner	—	—	0.47	Fs
		Passband ripple	f ≤ 0.45 Fs	-0.092	—	0.092	dB
		Stopband attenuation	f ≥ 0.55 Fs	98	—	—	dB
		Group delay <sup>1</sup>	linear phase minimum phase	— —	20.5/Fs 4.1/Fs	— —	s s
Fs = 44.1 kHz or 48 kHz	Fast roll-off	Passband	to -3 dB corner	—	—	0.48	Fs
		Passband ripple	f ≤ 0.46 Fs	-0.011	—	0.011	dB
		Stopband attenuation	f ≥ 0.54 Fs	98	—	—	dB
		Group delay <sup>1</sup>	linear phase minimum phase	— —	27.6/Fs 4.0/Fs	— —	s s
	Slow roll-off	Passband	to -3 dB corner	—	—	0.46	Fs
		Passband ripple	f ≤ 0.42 Fs	-0.099	—	0.099	dB
		Stopband attenuation	f ≥ 0.58 Fs	96	—	—	dB
		Group delay <sup>1</sup>	linear phase minimum phase	— —	13.3/Fs 3.9/Fs	— —	s s
Fs = 88.2 kHz or 96 kHz	Fast roll-off	Passband	to -3 dB corner	—	—	0.48	Fs
		Passband ripple	f ≤ 0.45 Fs	-0.006	—	0.006	dB
		Stopband attenuation	f ≥ 0.55 Fs	111	—	—	dB
		Group delay <sup>1</sup>	linear phase minimum phase	— —	32.3/Fs 6.3/Fs	— —	s s
	Slow roll-off	Passband	to -3 dB corner	—	—	0.43	Fs
		Passband ripple	f ≤ 0.27 Fs	-0.011	—	0.011	dB
		Stopband attenuation	f ≥ 0.77 Fs	103	—	—	dB
		Group delay <sup>1</sup>	linear phase minimum phase	— —	7.0/Fs 4.1/Fs	— —	s s
Fs = 176.4 kHz or 192 kHz	Fast roll-off	Passband	to -3 dB corner	—	—	0.47	Fs
		Passband ripple	f ≤ 0.43 Fs	-0.009	—	0.009	dB
		Stopband attenuation	f ≥ 0.57 Fs	99	—	—	dB
		Group delay <sup>1</sup>	linear phase minimum phase	— —	19.1/Fs 5.2/Fs	— —	s s
	Slow roll-off	Passband	to -3 dB corner	—	—	0.29	Fs
		Passband ripple	f ≤ 0.12 Fs	-0.010	—	0.010	dB
		Stopband attenuation	f ≥ 0.67 Fs	99	—	—	dB
		Group delay <sup>1</sup>	linear phase minimum phase	— —	6.4/Fs 4.2/Fs	— —	s s
Fs = 352.8 kHz or 384 kHz	Fast roll-off	Passband	to -3 dB corner	—	—	0.48	Fs
		Passband ripple	f ≤ 0.43 Fs	-0.010	—	0.010	dB
		Stopband attenuation	f ≥ 0.57 Fs	100	—	—	dB
		Group delay <sup>1</sup>	linear phase minimum phase	— —	23.8/Fs 7.5/Fs	— —	s s
	Slow roll-off	Passband	to -3 dB corner	—	—	0.34	Fs
		Passband ripple	f ≤ 0.12 Fs	-0.010	—	0.010	dB
		Stopband attenuation	f ≥ 0.67 Fs	129	—	—	dB
		Group delay <sup>1</sup>	linear phase minimum phase	— —	5.8/Fs 4.7/Fs	— —	s s

1. Group delay is measured from the time at which a signal is presented on the input pins (INnP/INnN) to the time of the first data bit of the corresponding FSYNC frame being output on the ASP\_DOUT pin.

**Table 3-7. ADC High-Pass Filter (HPF)**

Test conditions (unless specified otherwise): VDD\_A = VDD\_IO1 = VDD\_IO2 = 3.3 V; Ground = GND = GND\_A = PAD = GND\_D = 0 V; voltages are with respect to ground; T<sub>A</sub> = +25°C; 1 kHz sine wave test signal; F<sub>s</sub> = 48 kHz, 32-bit audio data.

Parameter		Min	Typ	Max	Units
Passband	–0.01 dB corner	—	19	—	Hz
	–3 dB corner	—	1	—	Hz
Phase deviation	f = 20 Hz	—	0.001	—	degree
Filter settling time		—	0.4	—	s

**Table 3-8. DAC Filter Characteristics**

Test conditions (unless specified otherwise): VDD\_A = VDD\_IO1 = VDD\_IO2 = 3.3 V; Ground = GND = GND\_A = PAD = GND\_D = 0 V; voltages are with respect to ground; T<sub>A</sub> = +25°C; 1 kHz sine wave test signal; F<sub>s</sub> = 48 kHz, 32-bit audio data.

Parameter		Min	Typ	Max	Units	
F <sub>s</sub> = 16 kHz	Fast roll-off	Passband to –3 dB corner	—	—	0.49	F <sub>s</sub>
		Passband ripple f ≤ 0.45 F <sub>s</sub>	–0.001	—	0.001	dB
		Stopband attenuation f ≥ 0.55 F <sub>s</sub>	100	—	—	dB
		Group delay <sup>1</sup>	—	32.5/F <sub>s</sub> 4.6/F <sub>s</sub>	—	s s
F <sub>s</sub> = 32 kHz	Fast roll-off	Passband to –3 dB corner	—	—	0.49	F <sub>s</sub>
		Passband ripple f ≤ 0.45 F <sub>s</sub>	–0.001	—	0.001	dB
		Stopband attenuation f ≥ 0.55 F <sub>s</sub>	100	—	—	dB
		Group delay <sup>1</sup>	—	32.5/F <sub>s</sub> 4.6/F <sub>s</sub>	—	s s
F <sub>s</sub> = 44.1 kHz or 48 kHz	Fast roll-off	Passband to –3 dB corner	—	—	0.49	F <sub>s</sub>
		Passband ripple f ≤ 0.45 F <sub>s</sub>	–0.001	—	0.001	dB
		Stopband attenuation f ≥ 0.55 F <sub>s</sub>	100	—	—	dB
		Group delay <sup>1</sup>	—	32.6/F <sub>s</sub> 4.7/F <sub>s</sub>	—	s s
	Slow roll-off	Passband to –3 dB corner	—	—	0.47	F <sub>s</sub>
		Passband ripple f ≤ 0.42 F <sub>s</sub>	–0.004	—	0.005	dB
		Stopband attenuation f ≥ 0.59 F <sub>s</sub>	101	—	—	dB
		Group delay <sup>1</sup>	—	17.1/F <sub>s</sub> 4.6/F <sub>s</sub>	—	s s
F <sub>s</sub> = 88.2 kHz or 96 kHz	Fast roll-off	Passband to –3 dB corner	—	—	0.49	F <sub>s</sub>
		Passband ripple f ≤ 0.45 F <sub>s</sub>	–0.001	—	0.001	dB
		Stopband attenuation f ≥ 0.55 F <sub>s</sub>	101	—	—	dB
		Group delay <sup>1</sup>	—	32.9/F <sub>s</sub> 5.0/F <sub>s</sub>	—	s s
	Slow roll-off	Passband to –3 dB corner	—	—	0.39	F <sub>s</sub>
		Passband ripple f ≤ 0.23 F <sub>s</sub>	–0.005	—	0.005	dB
		Stopband attenuation f ≥ 0.70 F <sub>s</sub>	90	—	—	dB
		Group delay <sup>1</sup>	—	7.4/F <sub>s</sub> 4.5/F <sub>s</sub>	—	s s
	Balanced roll-off	Passband to –3 dB corner	—	—	0.35	F <sub>s</sub>
		Passband ripple f ≤ 0.23 F <sub>s</sub>	–0.001	—	0.001	dB
		Stopband attenuation f ≥ 0.55 F <sub>s</sub>	101	—	—	dB
		Group delay <sup>1</sup>	—	11.6/F <sub>s</sub> 5.2/F <sub>s</sub>	—	s s

**Table 3-8. DAC Filter Characteristics (Cont.)**

Test conditions (unless specified otherwise): VDD\_A = VDD\_IO1 = VDD\_IO2 = 3.3 V; Ground = GND = GND\_A = PAD = GND\_D = 0 V; voltages are with respect to ground; T<sub>A</sub> = +25°C; 1 kHz sine wave test signal; F<sub>s</sub> = 48 kHz, 32-bit audio data.

Parameter		Min	Typ	Max	Units	
F <sub>s</sub> = 176.4 kHz or 192 kHz	Fast roll-off	Passband to -3 dB corner	—	—	0.48	F <sub>s</sub>
		Passband ripple f ≤ 0.45 F <sub>s</sub>	-0.004	—	0.005	dB
		Stopband attenuation f ≥ 0.55 F <sub>s</sub>	101	—	—	dB
		Group delay <sup>1</sup>	—	34.7/F <sub>s</sub> 6.3/F <sub>s</sub>	—	s s
	Slow roll-off	Passband to -3 dB corner	—	—	0.36	F <sub>s</sub>
		Passband ripple f ≤ 0.11 F <sub>s</sub>	-0.001	—	0.001	dB
		Stopband attenuation f ≥ 0.80 F <sub>s</sub>	108	—	—	dB
		Group delay <sup>1</sup>	—	7.6/F <sub>s</sub> 5.4/F <sub>s</sub>	—	s s
	Balanced roll-off	Passband to -3 dB corner	—	—	0.28	F <sub>s</sub>
		Passband ripple f ≤ 0.11 F <sub>s</sub>	-0.001	—	0.001	dB
		Stopband attenuation f ≥ 0.55 F <sub>s</sub>	109	—	—	dB
		Group delay <sup>1</sup>	—	10.6/F <sub>s</sub> 6.7/F <sub>s</sub>	—	s s
F <sub>s</sub> = 352.8 kHz or 384 kHz	Fast roll-off	Passband to -3 dB corner	—	—	0.28	F <sub>s</sub>
		Passband ripple f ≤ 0.45 F <sub>s</sub>	-0.004	—	0.000	dB
		Stopband attenuation f ≥ 0.55 F <sub>s</sub>	116	—	—	dB
		Group delay <sup>1</sup>	—	14.2/F <sub>s</sub> 7.5/F <sub>s</sub>	—	s s
	Balanced roll-off	Passband to -3 dB corner	—	—	0.22	F <sub>s</sub>
		Passband ripple f ≤ 0.11 F <sub>s</sub>	-0.001	—	0.000	dB
		Stopband attenuation f ≥ 0.55 F <sub>s</sub>	116	—	—	dB
		Group delay <sup>1</sup>	—	10.8/F <sub>s</sub> 7.6/F <sub>s</sub>	—	s s

1. Group delay is measured from the start of the FSYNC frame containing the audio data on the ASP\_DIN pin to the time at which the signal is presented on the output pins (OUTnP/OUTnN).

**Table 3-9. DAC High-Pass Filter (HPF)**

Test conditions (unless specified otherwise): VDD\_A = VDD\_IO1 = VDD\_IO2 = 3.3 V; Ground = GND = GND\_A = PAD = GND\_D = 0 V; voltages are with respect to ground;

T<sub>A</sub> = +25°C; 1 kHz sine wave test signal; F<sub>s</sub> = 48 kHz, 32-bit audio data.

Parameter	Min	Typ	Max	Units
Passband	—	19	—	Hz
	—	1	—	Hz
Phase deviation	—	0.001	—	degree
Filter settling time	—	0.4	—	s

**Table 3-10. Device Power Consumption**

Test conditions (unless specified otherwise): VDD\_A = VDD\_IO1 = VDD\_IO2 = 3.3 V; Ground = GND = GND\_A = PAD = GND\_D = 0 V; voltages are with respect to ground; T<sub>A</sub> = +25°C; 1 kHz sine wave test signal; F<sub>s</sub> = 48 kHz, 32-bit audio data.

Use Configuration	Typical Current (mA)			Total Power (mW)
	I <sub>VDD_A</sub>	I <sub>VDD_IO1</sub>	I <sub>VDD_IO2</sub>	
Reset	0.70	0.04	0.04	2.574

**Table 3-11. Digital Interface Specifications and Characteristics**

Test conditions (unless specified otherwise): Ground = GND = GND\_A = PAD = GND\_D = 0 V; voltages are with respect to ground; T<sub>A</sub> = +25°C.

Parameter		Symbol	Minimum	Maximum	Unit
Input leakage current (per pin)		I <sub>IN</sub>	—	±10	μA
Input capacitance (per pin)		C <sub>IN</sub>	—	5	pF
Digital I/O (VDD_IO1 logic pins; see Section 1) <sup>1</sup>	High-level output	V <sub>OH</sub>	0.9×VDD_IO1	—	V
	Low-level output	V <sub>OL</sub>	—	0.1×VDD_IO1	V
	High-level input	V <sub>IH</sub>	0.7×VDD_IO1	—	V
	Low-level input	V <sub>IL</sub>	—	0.3×VDD_IO1	V
Digital I/O (VDD_IO2 logic pins; see Section 1) <sup>1</sup>	High-level output	V <sub>OH</sub>	0.9×VDD_IO2	—	V
	Low-level output	V <sub>OL</sub>	—	0.1×VDD_IO2	V
	High-level input	V <sub>IH</sub>	0.7×VDD_IO2	—	V
	Low-level input	V <sub>IL</sub>	—	0.3×VDD_IO2	V

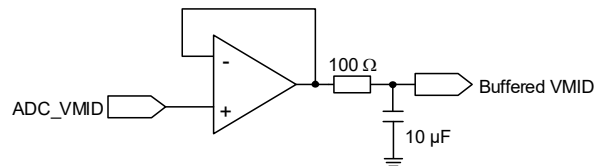
1. If the system clock is not supplied by the crystal oscillator, the XTAL\_IN and XTAL\_OUT pins are used to support HGC (Section 4.7) and virtual PAD (see Section 4.5.6).

**Table 3-12. DC Characteristics**

Test conditions (unless specified otherwise): VDD\_A = VDD\_IO1 = VDD\_IO2 = 3.3 V; Ground = GND = GND\_A = PAD = GND\_D = 0 V; voltages are with respect to ground; T<sub>A</sub> = +25°C.

Parameter		Minimum	Typical	Maximum	Unit
LDO_VD_FILT	Nominal voltage	—	1.2	—	V
DAC_FILT <sup>1</sup>	Nominal voltage	—	1.95	—	V
	VDD_A to DAC_FILT_P DAC_FILT_N to GND	—	1.9	—	V
DAC_VMID	Nominal voltage	—	1.65	—	V
	Maximum output current	—	50	—	nA
ADC_FILT <sup>2</sup>	Nominal voltage	—	3.3	—	V
	Maximum output current	—	0.01	—	mA
ADC_VMID <sup>3</sup>	Nominal voltage	—	1.65	—	V
	Maximum output current	—	0.01	—	mA
VDD_A power-on reset (POR) threshold (V <sub>POR</sub> )	VDD_A rising	2.0	—	2.8	V
	VDD_A falling	2.0	—	2.8	V
VDD_IO1 power-on reset (POR) threshold (V <sub>POR</sub> )	VDD_IO1 rising	1.08	—	1.58	V
	VDD_IO1 falling	0.99	—	1.43	V
VDD_IO2 power-on reset (POR) threshold (V <sub>POR</sub> )	VDD_IO2 rising	0.45	—	0.75	V
	VDD_IO2 falling	0.45	—	0.74	V

- DAC\_FILT characteristics are provided as a guide for external component selection. The output current (arising from capacitor leakage) must be less than the maximum output current of the DAC\_FILT\_x pin.
- ADC\_FILT characteristics are measured between ADC\_FILT\_P and ADC\_FILT\_N, and are provided as a guide for external component selection. The output current (arising from capacitor leakage) must be less than the maximum output current of the ADC\_FILT\_x pin.
- The output current (arising from capacitor leakage and the input-buffer circuit) must be less than the maximum output current of the ADC\_VMID pin. If a larger current is required, an external ADC\_VMID buffer should be used. A buffer can be provided using a standard op-amp (noise voltage < 5 nV/√Hz, input current < 10 μA), an example circuit is as follows.



**Table 3-13. Switching Specifications—Reset and Clock References**

Test conditions (unless specified otherwise): VDD\_A = VDD\_IO1 = VDD\_IO2 = 3.3 V; Ground = GND = GND\_A = PAD = GND\_D = 0 V; voltages are with respect to ground; T<sub>A</sub> = +25°C.

Parameter		Symbol	Minimum	Typical	Maximum	Unit
Reset	RESET low (logic 0) pulse width	t <sub>RLPW</sub>	1	—	—	ms
	RESET rising edge to control port active	t <sub>IRS</sub>	—	—	5	ms
MCLK input	MCLK frequency	f <sub>MCLK</sub>	—	24.576	—	MHz
			—	22.5792	—	MHz
			—	49.152	—	MHz
—			45.1584	—	MHz	
	MCLK duty cycle	D <sub>MCLK</sub>	45	—	55	%
	MCLK frequency tolerance	—	-1	—	1	%
MCLK output	MCLK frequency	f <sub>MCLK</sub>	—	24.576	—	MHz
			—	22.5792	—	MHz
			—	49.152	—	MHz
—			45.1584	—	MHz	
	MCLK duty cycle	D <sub>MCLK</sub>	45	—	55	%
	MCLK frequency accuracy	—	-1	—	1	%
Crystal	Oscillator frequency	f <sub>XTAL</sub>	—	24.576	—	MHz
			—	22.5792	—	MHz
—			49.152	—	MHz	
—			45.1584	—	MHz	
	Interface transconductance			26	—	mS
		VDD_IO2 = 3.3 V	—	43	—	mS
		VDD_IO2 = 1.8 V	—	—	—	mS

**Table 3-14. Switching Specifications—Audio Serial Port (ASP)**

Test conditions (unless specified otherwise): VDD\_A = VDD\_IO2 = 3.3 V; Ground = GND = GND\_A = PAD = GND\_D = 0 V; voltages are with respect to ground; input timings are measured at V<sub>IL</sub> and V<sub>IH</sub> thresholds, output timings are measured at V<sub>OL</sub> and V<sub>OH</sub> thresholds for VDD\_IO1 logic (as specified in Table 3-11); T<sub>A</sub> = 25°C.

Parameter 1,2,3,4,5		Symbol	Minimum	Maximum	Unit	
Secondary Mode, VDD_IO1 = 3.3 V	ASP_FSYNC input sample/frame rate	F <sub>s</sub>	16	384	kHz	
	ASP_FSYNC pulse width	t <sub>HI:FSYNC</sub>	1/f <sub>ASP_BCLK</sub>	—	ns	
	ASP_BCLK frequency	f <sub>BCLK</sub>	1.024	24.576	MHz	
	ASP_BCLK high period	t <sub>HI:BCLK</sub>	18	—	ns	
	ASP_BCLK low period	t <sub>LO:BCLK</sub>	18	—	ns	
	ASP_FSYNC setup time before ASP_BCLK latching edge	t <sub>SU:FSYNC</sub>	5	—	ns	
	ASP_FSYNC hold time after ASP_BCLK latching edge	t <sub>H:FSYNC</sub>	5	—	ns	
	ASP_DIN setup time before ASP_BCLK latching edge	t <sub>SU:DIN</sub>	10	—	ns	
	ASP_DIN hold time after ASP_BCLK latching	t <sub>H:DIN</sub>	5	—	ns	
	ASP_DOUT delay after ASP_BCLK launching edge	half-cycle mode, load = 50 pF full-cycle mode, load = 150 pF	t <sub>D:BCLK-DOUT</sub>	0	10	ns
				0	12	ns
	ASP_DOUT Hi-Z delay after ASP_BCLK latching edge	half-cycle mode, load = 50 pF full-cycle mode, load = 150 pF	t <sub>DLY:HiZ</sub>	0	9	ns
				0	9	ns
	ASP_DOUT delay from Hi-Z after ASP_BCLK launching edge	half-cycle mode, load = 50 pF full-cycle mode, load = 150 pF	t <sub>DLY:EN</sub>	0	10	ns
10				28	ns	
ASP_DOUT load capacitance	ASP_DOUT	—	0	150	pF	

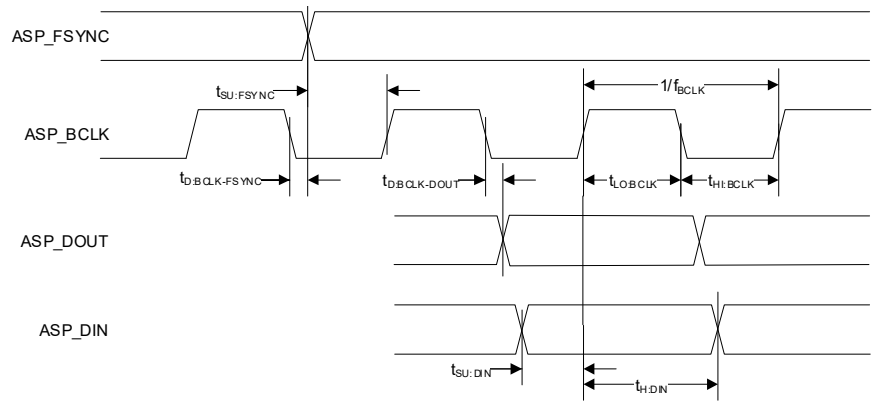
**Table 3-14. Switching Specifications—Audio Serial Port (ASP) (Cont.)**

Test conditions (unless specified otherwise): VDD\_A = VDD\_IO2 = 3.3 V; Ground = GND = GND\_A = PAD = GND\_D = 0 V; voltages are with respect to ground; input timings are measured at V<sub>IL</sub> and V<sub>IH</sub> thresholds, output timings are measured at V<sub>OL</sub> and V<sub>OH</sub> thresholds for VDD\_IO1 logic (as specified in Table 3-11); T<sub>A</sub> = 25°C.

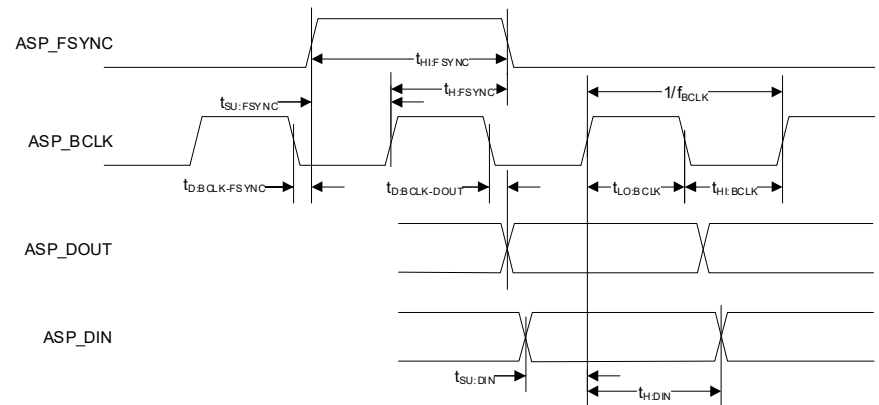
Parameter 1,2,3,4,5		Symbol	Minimum	Maximum	Unit	
Primary Mode, VDD_IO1 = 3.3 V	ASP_FSYNC output sample/frame rate	F <sub>s</sub>	16	384	kHz	
	ASP_BCLK frequency	f <sub>BCLK</sub>	2.8224	24.576	MHz	
	ASP_BCLK duty cycle	D <sub>BCLK</sub>	45	55	%	
	ASP_FSYNC delay time after ASP_BCLK launching edge	t <sub>D:BCLK-FSYNC</sub>	0	20	ns	
	ASP_DIN setup time before ASP_BCLK latching edge	t <sub>SU:DIN</sub>	6	—	ns	
	ASP_DIN hold time after ASP_BCLK latching edge	t <sub>H:DIN</sub>	5	—	ns	
	ASP_DOUT delay after ASP_BCLK launching edge	t <sub>D:BCLK-DOUT</sub>	half-cycle mode, load = 50 pF	0	11	ns
	full-cycle mode, load = 150 pF		0	13	ns	
	ASP_DOUT Hi-Z delay after ASP_BCLK latching edge	t <sub>DLY:HiZ</sub>	half-cycle mode, load = 50 pF	0	10	ns
	full-cycle mode, load = 150 pF		0	10	ns	
	ASP_DOUT delay from Hi-Z after ASP_BCLK launching edge	t <sub>DLY:EN</sub>	half-cycle mode, load = 50 pF	0	15	ns
full-cycle mode, load = 150 pF	7		28	ns		
ASP_x load capacitance	ASP_BCLK	—	0	50	pF	
	ASP_FSYNC		0	50	pF	
	ASP_DOUT		0	150	pF	
Secondary Mode, VDD_IO1 = 1.8 V	ASP_FSYNC input sample/frame rate	F <sub>s</sub>	16	384	kHz	
	ASP_FSYNC pulse width	t <sub>HI:FSYNC</sub>	1/f <sub>ASP_BCLK</sub>	—	ns	
	ASP_BCLK frequency	f <sub>BCLK</sub>	1.024	24.576	MHz	
	ASP_BCLK high period	t <sub>HI:BCLK</sub>	18	—	ns	
	ASP_BCLK low period	t <sub>LO:BCLK</sub>	18	—	ns	
	ASP_FSYNC setup time before ASP_BCLK latching edge	t <sub>SU:FSYNC</sub>	5	—	ns	
	ASP_FSYNC hold time after ASP_BCLK latching edge	t <sub>H:FSYNC</sub>	5	—	ns	
	ASP_DIN setup time before ASP_BCLK latching edge	t <sub>SU:DIN</sub>	10	—	ns	
	ASP_DIN hold time after ASP_BCLK latching	t <sub>H:DIN</sub>	5	—	ns	
	ASP_DOUT delay after ASP_BCLK launching edge	t <sub>D:BCLK-DOUT</sub>	half-cycle mode, load = 50 pF	0	15	ns
	full-cycle mode, load = 150 pF		0	17	ns	
	ASP_DOUT Hi-Z delay after ASP_BCLK latching edge	t <sub>DLY:HiZ</sub>	half-cycle mode, load = 50 pF	0	12	ns
	full-cycle mode, load = 150 pF		0	12	ns	
	ASP_DOUT delay from Hi-Z after ASP_BCLK launching edge	t <sub>DLY:EN</sub>	half-cycle mode, load = 50 pF	0	15	ns
full-cycle mode, load = 150 pF	11		33	ns		
ASP_DOUT load capacitance	ASP_DOUT	—	0	150	pF	
Primary Mode, VDD_IO1 = 1.8 V	ASP_FSYNC output sample/frame rate	F <sub>s</sub>	16	384	kHz	
	ASP_BCLK frequency	f <sub>BCLK</sub>	2.8224	24.576	MHz	
	ASP_BCLK duty cycle	D <sub>BCLK</sub>	45	55	%	
	ASP_FSYNC delay time after ASP_BCLK launching edge	t <sub>D:BCLK-FSYNC</sub>	0	20	ns	
	ASP_DIN setup time before ASP_BCLK latching edge	t <sub>SU:DIN</sub>	6	—	ns	
	ASP_DIN hold time after ASP_BCLK latching edge	t <sub>H:DIN</sub>	5	—	ns	
	ASP_DOUT delay after ASP_BCLK launching edge	t <sub>D:BCLK-DOUT</sub>	half-cycle mode, load = 50 pF	0	16	ns
	full-cycle mode, load = 150 pF		0	18	ns	
	ASP_DOUT Hi-Z delay after ASP_BCLK latching edge	t <sub>DLY:HiZ</sub>	half-cycle mode, load = 50 pF	0	13	ns
	full-cycle mode, load = 150 pF		0	13	ns	
	ASP_DOUT delay from Hi-Z after ASP_BCLK launching edge	t <sub>DLY:EN</sub>	half-cycle mode, load = 50 pF	0	15	ns
full-cycle mode, load = 150 pF	7		34	ns		
ASP_x load capacitance	ASP_BCLK	—	0	50	pF	
	ASP_FSYNC		0	50	pF	
	ASP_DOUT		0	150	pF	

1. The ASP\_BCLK launching edge is selectable. Half-cycle mode = ASP\_BCLK launching edge is opposite to latching edge. Full-cycle mode = ASP\_BCLK launching edge is same as latching edge.

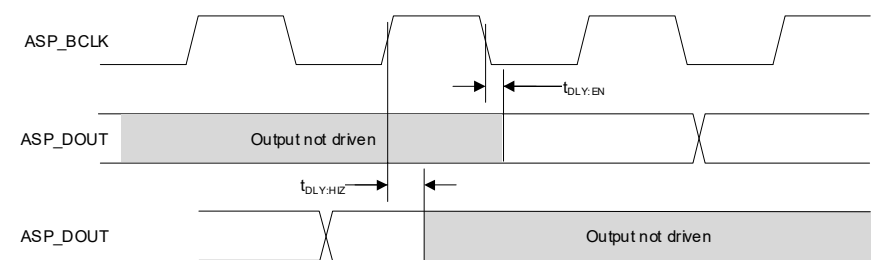
2. ASP timing in I<sup>2</sup>S and Left-Justified Modes.  
 ASP\_BCLK can be inverted if required; the figure shows the default polarity in half-cycle mode.



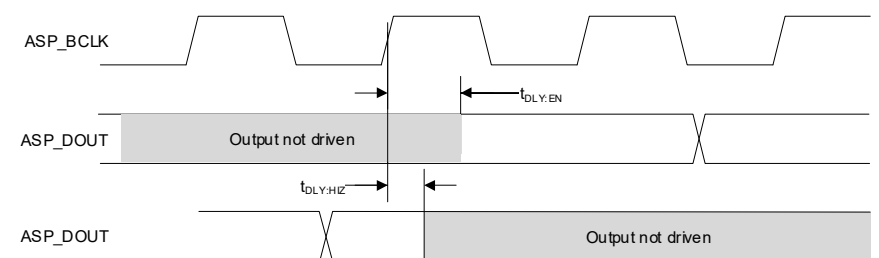
3. ASP timing in TDM Mode.  
 ASP\_BCLK can be inverted if required; the figure shows the default polarity in half-cycle mode.



4. ASP\_DOUT timing for multiple devices sharing the audio serial port bus—half-cycle mode.



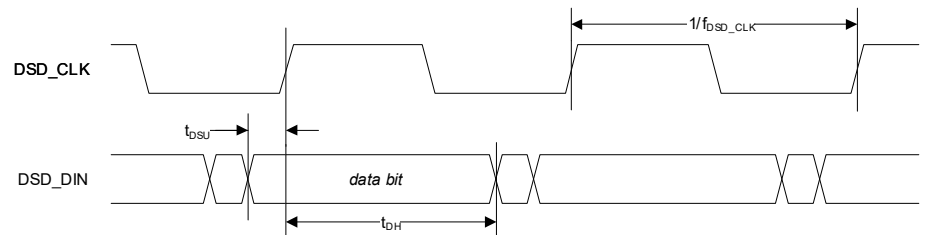
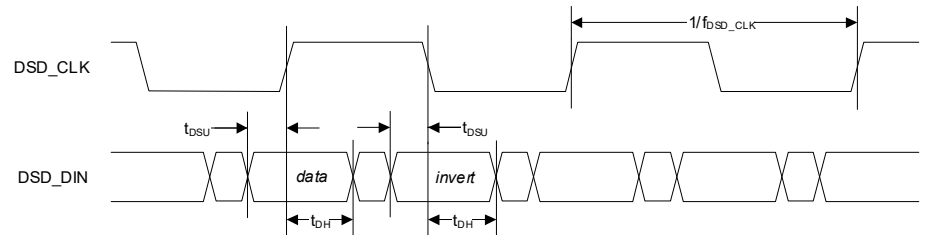
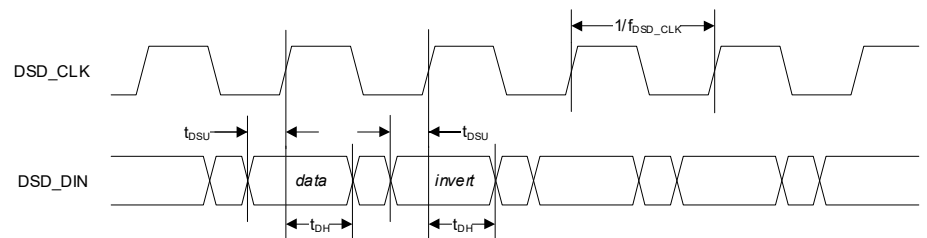
5. ASP\_DOUT timing for multiple devices sharing the audio serial port bus—full-cycle mode.



**Table 3-15. Switching Specifications—Direct Stream Digital (DSD) Interface**

Test conditions (unless specified otherwise): VDD\_A = VDD\_IO1 = 3.3 V; Ground = GND = GND\_A = PAD = GND\_D = 0 V; voltages are with respect to ground; input timings are measured at V<sub>IL</sub> and V<sub>IH</sub> thresholds, output timings are measured at V<sub>OL</sub> and V<sub>OH</sub> thresholds for VDD\_IO1 logic (as specified in Table 3-11); T<sub>A</sub> = 25°C.

Parameter 1,2,3		Symbol	Minimum	Maximum	Unit
Normal Mode	DSD_CLK frequency	f <sub>DSD_CLK</sub>	2.8224	22.5792	MHz
	DSD_CLK duty cycle	—	45	55	%
	DSD_DIN setup time to active DSD_CLK edge	t <sub>DSU</sub>	10	—	ns
	DSD_DIN fall time from active DSD_CLK edge	t <sub>DH</sub>	10	—	ns
Phase Modulation Mode	DSD_CLK frequency	f <sub>DSD_CLK</sub>	2.8224	2.8224	MHz
	DSD_CLK frequency	f <sub>DSD_CLK</sub>	5.6448	5.6448	MHz
	DSD_CLK duty cycle	—	45	55	%
	DSD_DIN setup time to active DSD_CLK edge	t <sub>DSU</sub>	10	—	ns
	DSD_DIN fall time from active DSD_CLK edge	t <sub>DH</sub>	10	—	ns

**1. DSD Normal Mode.**

**2. DSD Phase Modulation, (64fs CLK).**

**3. DSD Phase Modulation, (128fs CLK).**


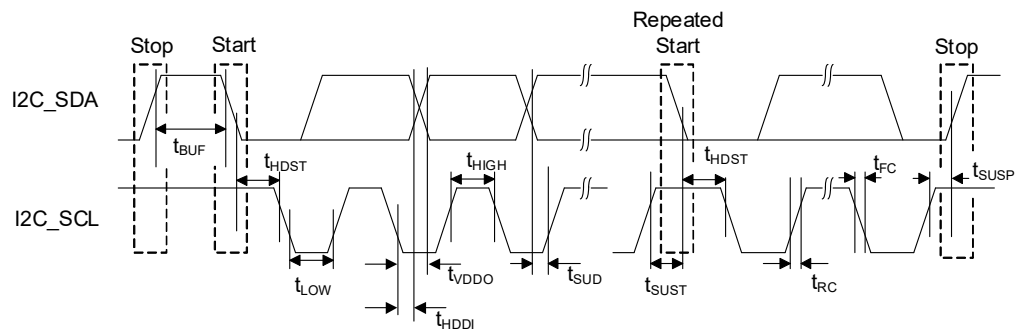
**Table 3-16. Switching Specifications—I<sup>2</sup>C Control Port**

Test conditions (unless specified otherwise): VDD\_A = VDD\_IO1 = VDD\_IO2 = 3.3 V; Ground = GND = GND\_A = PAD = GND\_D = 0 V; voltages are with respect to ground; input timings are measured at V<sub>IL</sub> and V<sub>IH</sub> thresholds, output timings are measured at V<sub>OL</sub> and V<sub>OH</sub> thresholds for VDD\_IO1 logic (as specified in Table 3-11); T<sub>A</sub> = 25°C.

Parameter <sup>1,2</sup>	Symbol	Minimum	Maximum	Unit
SCL clock frequency	f <sub>SCL</sub>	—	1000	kHz
Clock low time	t <sub>LOW</sub>	500	—	ns
Clock high time	t <sub>HIGH</sub>	260	—	ns
Start condition hold time (before first clock pulse)	t <sub>HDST</sub>	260	—	ns
Setup time for repeated start	t <sub>SUST</sub>	260	—	ns
Rise time of SCL and SDA	f <sub>SCL</sub> ≤ 100 kHz	600	1000	ns
	100 kHz < f <sub>SCL</sub> ≤ 400 kHz	180	300	ns
	400 kHz < f <sub>SCL</sub> ≤ 1000 kHz	72	120	ns
Fall time of SCL and SDA	f <sub>SCL</sub> ≤ 100 kHz	6.5	300	ns
	100 kHz < f <sub>SCL</sub> ≤ 400 kHz	6.5	300	ns
	400 kHz < f <sub>SCL</sub> ≤ 1000 kHz	6.5	120	ns
Rise time variation between SDA and SCL	—	—	1.67	ns
Fall time variation between SDA and SCL	f <sub>SCL</sub> ≤ 100 kHz	—	100	ns
	100 kHz < f <sub>SCL</sub> ≤ 400 kHz	—	100	ns
	400 kHz < f <sub>SCL</sub> ≤ 1000 kHz	—	75	ns
Setup time for stop condition	t <sub>SUSP</sub>	260	—	ns
SDA setup time to SCL rising	t <sub>SUD</sub>	50	—	ns
SDA input hold time from SCL falling <sup>3</sup>	t <sub>HDDI</sub>	0	—	ns
Output data valid (Data/ACK) <sup>4</sup>	f <sub>SCL</sub> ≤ 100 kHz	—	3450	ns
	100 kHz < f <sub>SCL</sub> ≤ 400 kHz	—	900	ns
	400 kHz < f <sub>SCL</sub> ≤ 1000 kHz	—	450	ns
Bus free time between transmissions	t <sub>BUF</sub>	500	—	ns
SDA bus capacitance	C <sub>B</sub>	—	550	pF
SCL/SDA pull-up resistance	R <sub>P</sub>	500	—	Ω
Pulse width of spikes to be suppressed	t <sub>ps</sub>	0	50	ns

1. All timing is relative to thresholds specified in Table 3-11, V<sub>IL</sub> and V<sub>IH</sub> for input signals, and V<sub>OL</sub> and V<sub>OH</sub> for output signals.

2. I<sup>2</sup>C control-port timing.



3. Data must be held long enough to bridge the transition time, t<sub>FC</sub>, of SCL.

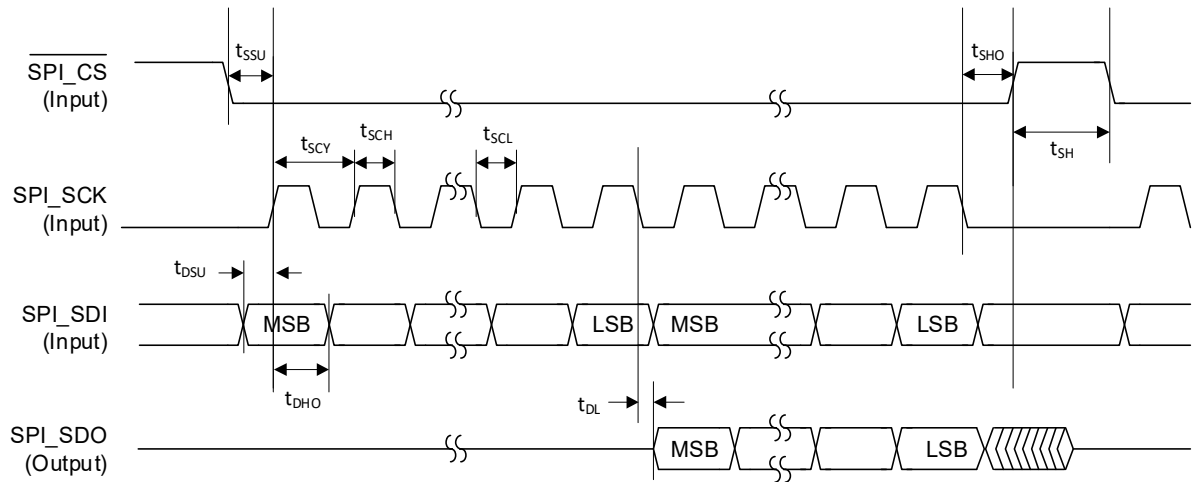
4. Time from falling edge of SCL until data output is valid.

**Table 3-17. Switching Specifications—SPI Control Port**

Test conditions (unless specified otherwise): VDD\_A = VDD\_IO = 3.3 V; Ground = GND = GND\_A = PAD = GND\_D = 0 V; voltages are with respect to ground; input timings are measured at V<sub>IL</sub> and V<sub>IH</sub> thresholds, output timings are measured at V<sub>OL</sub> and V<sub>OH</sub> thresholds for VDD\_IO1 logic (as specified in Table 3-11); T<sub>A</sub> = 25°C.

Parameter <sup>1</sup>	Symbol	Minimum	Maximum	Unit
SPI_SCK frequency	f <sub>SCY</sub>	—	24	MHz
SPI_CS falling edge to SPI_SCK rising edge	t <sub>SSU</sub>	5	—	ns
SPI_SCK falling edge to SPI_CS rising edge	t <sub>SHO</sub>	0.5	—	ns
SPI_SCK pulse width low	t <sub>SCL</sub>	18.5	—	ns
SPI_SCK pulse width high	t <sub>SCH</sub>	18.5	—	ns
SPI_SDI to SPI_SCK setup time	t <sub>DSU</sub>	5	—	ns
SPI_SDI to SPI_SCK hold time	t <sub>DHO</sub>	2.5	—	ns
SPI_SCK falling edge to SPI_SDO transition	t <sub>DL</sub>	0	15	ns
SPI_CS rising edge to SPI_SDO output high-Z	—	0	15	ns
Bus free time between active SPI_CS	t <sub>SH</sub>	20	—	ns

1. SPI control-port timing.

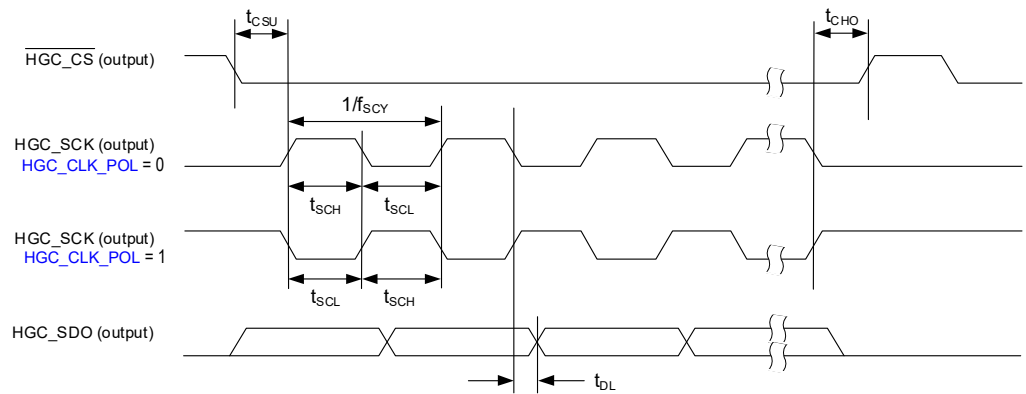


**Table 3-18. Switching Specifications—SPI Controller (Hybrid Gain Control)**

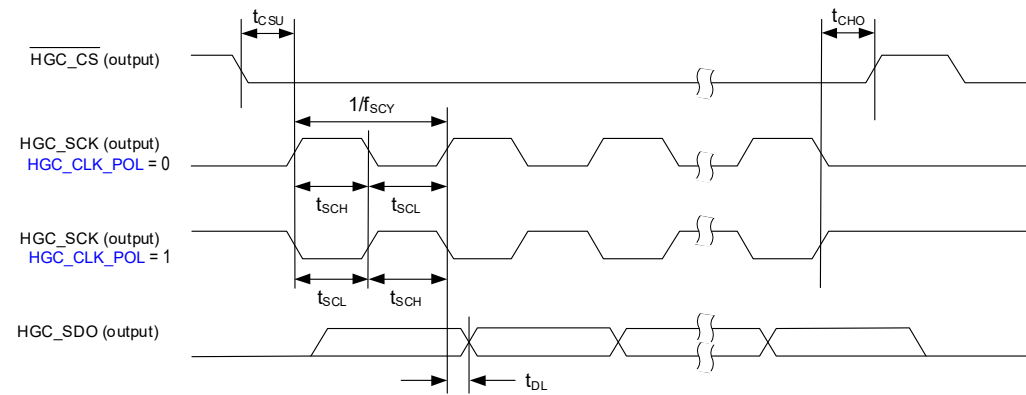
Test conditions (unless specified otherwise): VDD\_A = VDD\_IO1 = VDD\_IO2 = 3.3 V; Ground = GND = GND\_A = PAD = GND\_D = 0 V; voltages are with respect to ground; output timings are measured at V<sub>OL</sub> and V<sub>OH</sub> thresholds for VDD\_IO2 logic (as specified in Table 3-11); T<sub>A</sub> = 25°C.

Parameter 1,2	Symbol	Minimum	Maximum	Unit
HGC_SCK frequency	f <sub>SCY</sub>	—	12.288	MHz
HGC_CS falling edge to HGC_SCK rising edge	t <sub>CSU</sub>	30	—	ns
HGC_SCK falling edge to HGC_CS rising edge	t <sub>CHO</sub>	30	—	ns
HGC_SCK pulse width low	t <sub>SCL</sub>	40	—	ns
HGC_SCK pulse width high	t <sub>SCH</sub>	40	—	ns
HGC_SCK falling edge to HGC_SDO transition	t <sub>DL</sub>	-15	15	ns
		C <sub>LOAD</sub> (HGC_SDO) = 30 pF		
		C <sub>LOAD</sub> (HGC_SDO) = 60 pF		ns

1. SPI Master timing, HGC\_CLK\_PHA = 0.



2. SPI Master timing, HGC\_CLK\_PHA = 1.



## 4 Functional Description

### 4.1 Device Power and Reset

The CS4233S is powered using VDD\_A1, VDD\_A2, VDD\_IO1, and VDD\_IO2 external supplies.

**Notes:** The VDD\_A1 and VDD\_A2 rails should be tied together and powered from a single supply. The associated power domain is referred to as VDD\_A.

VDD\_IO1 and VDD\_IO2 are independent power domains. VDD\_IO1 supplies host-related interfaces (e.g., SPI control interface); VDD\_IO2 supplies external interfaces (e.g., crystal oscillator connections). Integrated level shifters are included for direct interface to logic levels from 1.8 V to 3.3 V.

There are no power-sequencing requirements—supplies can be enabled in any order.

The CS4233S is in reset if the  $\overline{\text{RESET}}$  pin is asserted (Logic 0), or if the VDD\_A supply is below the respective reset threshold defined in [Table 3-12](#).

All ground pins, including the ground paddle, must be tied to a common ground (GND) plane directly underneath the CS4233S.

### 4.2 Hardware Configuration

The CS4233S supports hardware and software control modes. In hardware mode, the device configuration is determined entirely by external resistors connected to the hardware-control pins. In software mode, the I<sup>2</sup>C/SPI control port is used to configure the device.

In hardware mode, the audio serial port (ASP) configuration is selected using the CONFIG1 and CONFIG2 pins as described in [Table 4-1](#). See [Section 4.4](#) for more details of the sample-rate selection and [Section 4.9](#) for more details of the ASP operation.

**Note:** The DSD interface ([Section 4.10](#)) is not supported in hardware control mode.

**Table 4-1. Hardware Control—ASP Configuration**

Pin Name	Pin Configuration	Description	
CONFIG1	Pull-up to VDD_IO1	0 Ω	Software control mode (I <sup>2</sup> C/SPI)
		4.7 kΩ	In I <sup>2</sup> C Mode, the pull-up resistor is used to select the device address—see <a href="#">Section 4.11</a> .
		22 kΩ	In SPI Mode, it is recommended to use a 100 kΩ pull-up resistor.
		100 kΩ	
	Pull-down to GND_D	100 kΩ	ASP Primary Mode, 176.4 kHz, 192 kHz sample rate
		22 kΩ	ASP Primary Mode, 88.2 kHz, 96 kHz sample rate
		4.7 kΩ	ASP Primary Mode, 44.1 kHz, 48 kHz sample rate
		0 Ω	ASP Secondary Mode, autodetect sample rate
CONFIG2	Pull-up to VDD_IO1	0 Ω	ASP TDM Mode—minimum time slots <sup>1</sup> , <a href="#">ASP_FSYNC_TYPE</a> = pulse
		4.7 kΩ	ASP TDM Mode—maximum time slots <sup>2</sup> , data output on BCLK falling edge (half-cycle mode) <sup>3</sup> , <a href="#">ASP_FSYNC_TYPE</a> = pulse
		22 kΩ	ASP TDM Mode—maximum time slots <sup>2</sup> , data output on BCLK rising edge (full-cycle mode) <sup>4</sup> , <a href="#">ASP_FSYNC_TYPE</a> = pulse
		100 kΩ	ASP TDM Mode—minimum time slots <sup>1</sup> , <a href="#">ASP_FSYNC_TYPE</a> = square wave (50% duty cycle) <sup>5</sup>
	Pull-down to GND_D	100 kΩ	ASP TDM Mode—maximum time slots <sup>2</sup> , data output on BCLK falling edge (half-cycle mode) <sup>3</sup> , <a href="#">ASP_FSYNC_TYPE</a> = square wave (50% duty cycle) <sup>5</sup>
		22 kΩ	ASP TDM Mode—maximum time slots <sup>2</sup> , data output on BCLK rising edge (full-cycle mode) <sup>4</sup> , <a href="#">ASP_FSYNC_TYPE</a> = square wave (50% duty cycle) <sup>5</sup>
		4.7 kΩ	ASP Left-Justified Mode
		0 Ω	ASP I <sup>2</sup> S Mode

1. The ASP data format is configured to support two time slots; this is the minimum necessary for the CS4233S input/output.

2. The ASP data format is configured to support the maximum number of time slots for the applicable BCLK rate, refer to [Table 4-16](#).

3. Half-cycle mode = ASP\_DOUT launching edge (BCLK falling) is opposite to the receiving-device latching edge (BCLK rising), refer to [Table 3-14](#).

4. Full-cycle mode = ASP\_DOUT launching edge (BCLK rising) is same as the receiving-device latching edge, refer to [Table 3-14](#).

5. [ASP\\_FSYNC\\_TYPE](#) = square wave (50% duty cycle) is available in ASP Primary Mode only, as described in [Section 4.9](#).

If the ASP is configured for TDM data format with maximum time slots, the TDM slot selection is determined using the CONFIG3 pin as described in [Table 4-2](#). See [Section 4.9](#) for more details of the ASP TDM modes.

**Table 4-2. Hardware Control—TDM Slot Selection**

Pin Name	Pin Configuration		Description
CONFIG3	Pull-up to VDD_IO1	0 Ω	Slots 14–15 [1]
		4.7 kΩ	Slots 12–13 [1]
		22 kΩ	Slots 10–11 [1]
		100 kΩ	Slots 8–9 [1]
	Pull-down to GND_D	100 kΩ	Slots 6–7 [2]
		22 kΩ	Slots 4–5 [2]
		4.7 kΩ	Slots 2–3
		0 Ω	Slots 0–1

1. Slots 8–15 are only valid in 16-slot TDM Mode.

2. Slots 4–7 are only valid in 8-slot or 16-slot TDM Mode.

The clock-reference and virtual PAD configurations are determined using the CONFIG4 pin as described in [Table 4-3](#). See [Section 4.4](#) for more details of the CS4233S clocking architecture, and [Section 4.5.6](#) for more details of virtual PAD function.

**Table 4-3. Hardware Control—Clocking Configuration**

Pin Name	Pin Configuration		Clock Reference	Reference Clock Frequency (MHz) <sup>1</sup>	Virtual PAD
CONFIG4	Pull-up to VDD_IO1	0 Ω	XTAL	1024 fs(base)	Bypassed
		4.7 kΩ	XTAL	512 fs(base)	
		22 kΩ	MCLK	1024 fs(base)	
		100 kΩ	MCLK	512 fs(base)	
	Pull-down to GND_D	100 kΩ	MCLK	1024 fs(base)	Enabled - Level Detection
		22 kΩ	MCLK	512 fs(base)	Enabled - Edge Detection <sup>2</sup>
		4.7 kΩ	MCLK	1024 fs(base)	
		0 Ω	MCLK	512 fs(base)	

1. fs(base) is the base sample rate. fs(base) = 48 kHz for 48 kHz-related sample rates; or 44.1 kHz for 44.1 kHz-related sample rates.

2. If CONFIG4 is configured for virtual PAD edge-detection switching, the GPIO1 pin is configured as a logic output; in this case, the DAC shutdown function is not supported (for details of DAC shutdown, see [Section 4.6.5](#))

In hardware mode, the digital filter is selected using the CONFIG5 pin. The filter selection differs between the ADC input path and the DAC output path. See [Section 4.8](#) for more details of the digital filters.

The filter selection for the ADC input path is defined in [Table 4-4](#). The filter selection is dependent on the sample rate, as described in Footnote 1 in [Table 4-4](#).

**Table 4-4. Hardware Control—ADC Input Digital Filter Selection**

Pin Name	Pin Configuration		ADC Decimation Filter <sup>1</sup>	High-Pass Filter (HPF)
CONFIG5	Pull-up to VDD_IO1	0 Ω	Minimum phase, slow roll-off	Bypassed
		4.7 kΩ	Minimum phase, fast roll-off	
		22 kΩ	Linear phase, slow roll-off	
		100 kΩ	Linear phase, fast roll-off	
	Pull-down to GND_D	100 kΩ	Linear phase, fast roll-off	Enabled
		22 kΩ	Linear phase, slow roll-off	
		4.7 kΩ	Minimum phase, fast roll-off	
		0 Ω	Minimum phase, slow roll-off	

1. Fast roll-off filters are supported for all sample rates. Slow roll-off filters are not valid for 16 kHz or 32 kHz sample rates.

The filter selection for the DAC output path is defined in [Table 4-5](#). The filter selection is dependent on the sample rate, as described in Footnote 1 in [Table 4-5](#).

**Table 4-5. Hardware Control—DAC Output Digital Filter Selection**

Pin Name	Pin Configuration		DAC Interpolation Filter		High-Pass Filter (HPF)
			16–48 kHz Sample Rate <sup>1</sup>	88.2–384 kHz Sample Rate	
CONFIG5	Pull-up to VDD_IO1	0 Ω	Minimum phase, slow roll-off	Minimum phase, balanced roll-off	Bypassed
		4.7 kΩ	Minimum phase, fast roll-off	Minimum phase, fast roll-off	
		22 kΩ	Linear phase, slow roll-off	Linear phase, balanced roll-off	
		100 kΩ	Linear phase, fast roll-off	Linear phase, fast roll-off	
	Pull-down to GND_D	100 kΩ	Linear phase, fast roll-off	Linear phase, fast roll-off	Enabled
		22 kΩ	Linear phase, slow roll-off	Linear phase, balanced roll-off	
		4.7 kΩ	Minimum phase, fast roll-off	Minimum phase, fast roll-off	
		0 Ω	Minimum phase, slow roll-off	Minimum phase, balanced roll-off	

1. Fast roll-off filters are supported for all sample rates. Slow roll-off filters are not valid for 16 kHz or 32 kHz sample rates.

In hardware mode, the device configuration is latched when reset is released (either power-on reset or deassertion of the  $\overline{\text{RESET}}$  pin). In hardware mode, the configuration cannot be changed while the device is operational. To update the device configuration, the  $\overline{\text{RESET}}$  pin must be asserted (Logic 0), or the device power cycled, in order to read new settings on the CONFIGx pins.

If software mode is selected (i.e., CONFIG1 is pulled-up to VDD\_IO1), the device configuration and the digital-filter selection are controlled by register writes via the applicable control interface, as described in [Section 4.11](#). Unused CONFIGx pins should be terminated as described in [Section 1.3](#).

**Note:** In software mode, the CONFIG1 pin is used to select the I<sup>2</sup>C target address (see [Section 4.11](#)). If the SPI control interface is used, it is recommended to connect the CONFIG1 pin to VDD\_IO1 via a 100 kΩ resistor.

### 4.3 Software Configuration

Software control mode is enabled if the CONFIG1 pin is pulled-up to VDD\_IO1; note that  $\overline{\text{RESET}}$  must remain asserted (i.e., Logic\_0) until CONFIG\_1/SPI\_CS is deasserted (i.e., Logic\_1). In software control mode, the CS4233S is configured by writing to control registers using the control port.

The control port supports I<sup>2</sup>C and SPI modes of operation; the applicable mode is detected automatically on the respective interface pins. In I<sup>2</sup>C mode, the target address is selectable using the CONFIG1 pin. See [Section 4.11](#) for further details of the I<sup>2</sup>C/SPI control port.

In software control mode, [GLOBAL\\_EN](#) is used as the global control field for enabling/disabling the CS4233S functions. The device should be configured using the applicable control registers before setting [GLOBAL\\_EN](#).

**Notes:** The clocking ([Section 4.4](#)) and ASP ([Section 4.9](#)) control registers are only valid on the rising edge of [GLOBAL\\_EN](#). Writing to these registers has no effect at any other time. It is recommended to select the disabled state ([GLOBAL\\_EN](#) = 0) before writing to these registers.

To minimize the CS4233S power consumption when all output paths are disabled, see [Section 4.6.5](#).

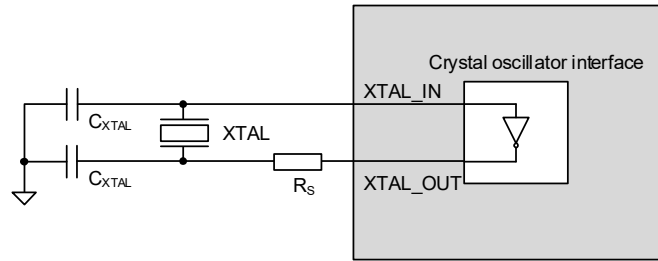
A reset of the CS4233S can be triggered by writing 0x5A to the [SW\\_RESET](#) field. A software reset disables all functions and sets the control registers to their default states.

### 4.4 System Clocking

Clocking for the CS4233S is provided using either the MCLK input or the crystal oscillator. In each case, the frequency must be 1024 fs(base) or 512 fs(base); where fs(base) = 48 kHz (for 48 kHz-related sample rates), or 44.1 kHz (for 44.1 kHz-related sample rates). The specifications for the clocking sources are described in [Table 3-13](#); for optimal out-of-band noise performance a system clock rate of 1024 fs(base) is recommended.

In hardware mode, the clock source is configured using the CONFIG4 pin, as detailed in [Table 4-3](#). In software mode, the clocking source is selected using [SYSCLK\\_SRC](#).

The crystal oscillator uses an external crystal (XTAL) to generate the system clock. Load capacitors are connected to the crystal as shown in Fig. 4-1. A series resistor ( $R_S$ ) may also be required to configure the drive level for the selected crystal.



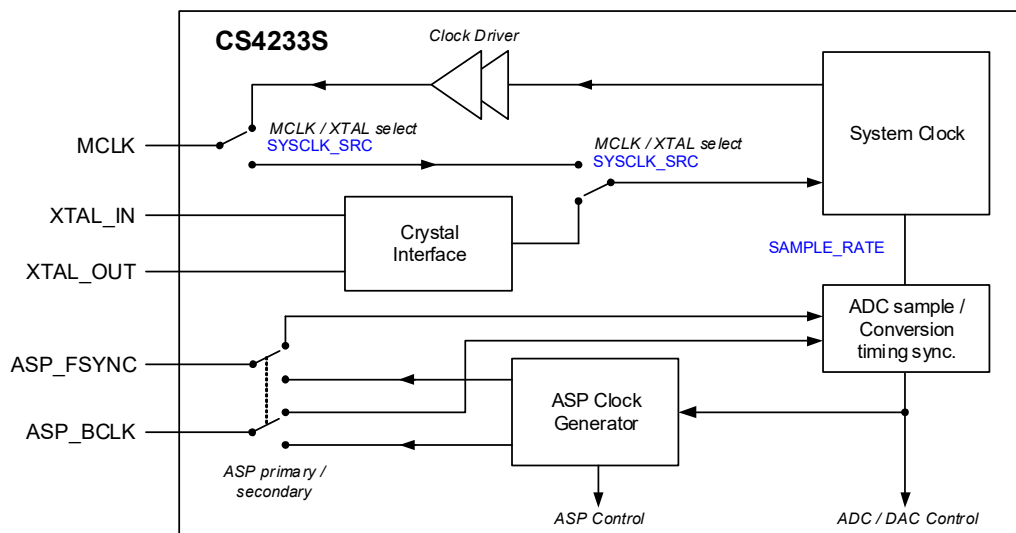
**Figure 4-1. Crystal Oscillator Connection**

Guidance on selecting a suitable crystal and associated components is provided in Section 5.3. The suitability of the external crystal is calculated as a function of the operating voltage ( $V_{DD\_IO2}$ ) and the transconductance of the crystal interface, as defined in Table 3-13.

If clocking is provided using the crystal oscillator, the CS4233S outputs a clock on the MCLK pin. The frequency of the MCLK output clock matches the crystal oscillator frequency. The output clock can be used to drive other devices.

In ASP Secondary Mode, the ASP\_FSYNC input is used to control the ADC-sample and DAC-conversion timing, enabling multiple CS4233S devices to operate synchronously (sample timing is phase aligned) in a system. The external clocks ASP\_FSYNC and ASP\_BCLK must be derived from a common clock source (i.e., the MCLK input, or the MCLK output when clocking is provided using the crystal oscillator). See Section 4.9 for more details of the ASP.

The clocking architecture is illustrated in Fig. 4-2.



**Figure 4-2. System Clocking**

### 4.4.1 Hardware Control Mode

In hardware control mode, the system clock can be sourced from the MCLK pin or from the crystal oscillator. In each case, the frequency must be 1024 fs(base) or 512 fs(base); where fs(base) = 48 kHz (for 48 kHz-related sample rates), or 44.1 kHz (for 44.1 kHz-related sample rates). The clock source is configured using the CONFIG4 pin as described in Section 4.2.

The sample rate is selected using the CONFIG1 pin as described in Section 4.2. Sample rates 44.1 kHz–192 kHz can be configured, or else the autodetect option (sample rates 16 kHz–192 kHz) automatically configures the device according to the ASP interface clock signals. The autodetect sample-rate option is only valid if the ASP is operating in Secondary Mode (see Section 4.9).

The supported clocking configurations are summarized in [Table 4-6](#).

**Table 4-6. System Clock Configuration**

Reference Source	Reference Frequency (MHz)	ASP Operating Conditions <sup>1</sup>
MCLK or XTAL	24.576 or 49.152	Primary or Secondary Mode, I <sup>2</sup> S, left-justified, or TDM data formats, sample rates 48, 96, and 192 kHz Primary Mode, or sample rates 16, 32, 48, 96, and 192 kHz in Secondary Mode (autodetect only).
MCLK or XTAL	22.5792 or 45.1584	Primary or Secondary Mode, I <sup>2</sup> S, left-justified, or TDM data formats, sample rates 44.1, 88.2, 176.4 kHz in Primary Mode, or sample rates 44.1, 88.2, 176.4 kHz in Secondary Mode (autodetect only).

1. See [Section 4.9](#) for details of the audio serial port (ASP).

The sample rate must be related to the system clock reference as described in [Table 4-7](#).

**Table 4-7. Hardware Control Mode Sample Rate Options**

Reference Source	Reference Frequency (MHz)	MCLK Out (MHz)	Sample Rate (kHz)
MCLK	22.5792 or 45.1584	—	44.1, 88.2, 176.4
	24.576 or 49.152		16, 32, 48, 96, 192
XTAL	22.5792 or 45.1584	22.5792 or 45.1584	44.1, 88.2, 176.4
	24.576 or 49.152	24.576 or 49.152	16, 32, 48, 96, 192

If the ASP is configured in ASP Secondary Mode, the external clocks (MCLK, BCLK, and FSYNC) must be derived from a common clock source. The clocks must be synchronized, but the phase difference is not important. If clocking for the CS4233S is provided using the crystal oscillator, then the BCLK and FSYNC signals should be derived from the common clock source provided by the CS4233S MCLK output, see [Section 4.9](#).

#### 4.4.2 Software Control Mode—ASP Input

In software (I<sup>2</sup>C/SPI) control mode, with the ASP interface selected as the audio source (see [Section 4.9](#)), the clocking configuration is selected using the following control fields:

- The sample rate is configured using [SAMPLE\\_RATE](#). Sample rates 16 kHz–384 kHz can be configured, or else the autodetect option automatically configures the device according to the ASP interface signals. The sample-rate autodetect option is only valid for sample rates 16 kHz–192 kHz.
- The system clock source is selected using [SYSCLK\\_SRC](#). The clock source can be either the crystal oscillator or MCLK.
- The system clock frequency is configured using [SYSCLK\\_FREQ](#). The system clock frequency must be 1024 fs(base) or 512 fs(base); where fs(base) = 48 kHz (for 48 kHz-related sample rates), or 44.1 kHz (for 44.1 kHz-related sample rates).

The sample rate must be related to the system clock reference as described in [Table 4-8](#).

**Table 4-8. Software Control Mode Sample Rate Options**

Reference Source	Reference Frequency (MHz)	MCLK Out (MHz)	Sample Rate (kHz)
MCLK	22.5792 or 45.1584	—	44.1, 88.2, 176.4, 352.8
	24.576 or 49.152		16, 32, 48, 96, 192, 384
XTAL	22.5792 or 45.1584	22.5792 or 45.1584	44.1, 88.2, 176.4, 352.8
	24.576 or 49.152	24.576 or 49.152	16, 32, 48, 96, 192, 384

The sample-rate autodetect option (16 kHz–192 kHz) is only valid if the ASP is operating in Secondary Mode (see [Section 4.9](#)).

If the ASP is configured in ASP Secondary Mode, the external clocks (MCLK, BCLK, and FSYNC) must be derived from a common clock source. The clocks must be synchronized, but the phase difference is not important. If clocking for the CS4233S is provided using the crystal oscillator, then the BCLK and FSYNC signals should be derived from the common clock source provided by the CS4233S MCLK output, see [Section 4.9](#).

### 4.4.3 Software Control Mode—DSD Input

In software (I<sup>2</sup>C/SPI) control mode, with the DSD interface selected as the audio source (see [Section 4.10](#)), the clocking configuration is selected using the following control fields:

- The system clock source is selected using `SYSCLK_SRC`. The clock source can be either the crystal oscillator or the MCLK input.
- The system clock frequency is configured using `SYSCLK_FREQ`. The system clock frequency must be 22.5792 MHz.
- The DSD clock, `DSD_CLK`, frequency is configured using `DSD_OSR` as described in [Section 4.10.2](#).

The external clocks; i.e., the system clock (MCLK or crystal oscillator) and `DSD_CLK` must be derived from a common clock source. The clocks must be synchronized, but the phase difference is not important. If clocking for the CS4233S is provided using the crystal oscillator, then the `DSD_CLK` signal should be derived from the common clock source provided by the CS4233S MCLK output, see [Section 4.9](#).

## 4.5 ADC and Analog Input

The CS4233S supports two analog input channels, each incorporating a high-performance sigma-delta analog-to-digital converter (ADC) with integrated programmable analog gain. Digital volume and mute control is also provided on each input channel.

The analog gain, digital volume, and mute controls are supported in software (I<sup>2</sup>C/SPI) control mode only.

### 4.5.1 ADC Path Enable

The analog input and ADC paths are enabled using `INx_ADC_EN` (where x indicates the channel number 1–2).

**Note:** Both input paths (1–2) must always be configured in the same state (enabled or disabled). For example, input path 1 should not be enabled without also enabling input path 2.

The polarity of the ADC output can be inverted using `INx_INV` for the respective channel.

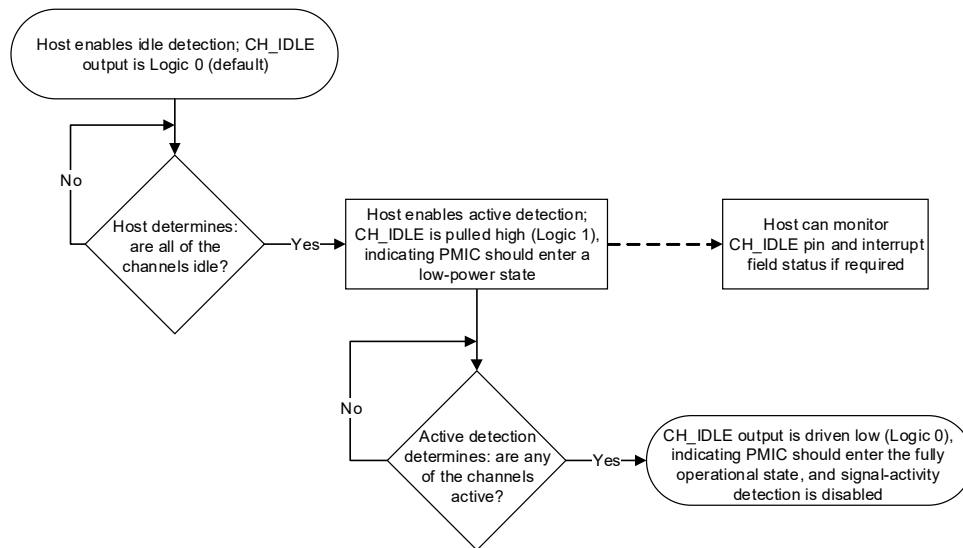
### 4.5.2 Signal-Activity Detection

The CS4233S incorporates a signal-activity detection function, enabling the host to control power-management circuits and related functions according to the status of the ADC input channels. The signal-activity detection function controls the `CH_IDLE` pin output. In a typical use case, `CH_IDLE` connects to an external PMIC, to control the power supply to the CS4233S input buffers. The Logic 0 output selects the fully operational condition; the Logic 1 output selects a low-power operating state.

The signal-activity detection function comprises two features:

- Idle detection: used to determine if the ADC channels are idle. A latching status bit is set if any of the input signals exceed a low-level threshold. The host clears this bit by writing 1. The idle status can be determined by the host on the basis that the status bit is not set for a required duration. Note that the `CH_IDLE` pin is not controlled by idle detection.
- Active detection: used to control the `CH_IDLE` pin. `CH_IDLE` is driven low (Logic 0) by default. If active detection is enabled, `CH_IDLE` is pulled high (Logic 1); if a high-level threshold is exceeded on any channel, `CH_IDLE` is driven low (Logic 0) and signal-activity detection (active and idle detection) is disabled. An external pull-up resistor, typically 10 k $\Omega$ , is required on `CH_IDLE`.

Idle detection is used to determine if all input channels are idle. In this event, the host enables active detection, which also selects the low-power PMIC operating state using the CH\_IDLE output. If an active signal is detected on any channel, the CH\_IDLE pin reverts to Logic 0 to select the fully operational PMIC condition, as illustrated in Fig. 4-3.



**Figure 4-3. Signal Activity Detection Operation**

Idle detection is enabled using `IN_SIG_ACT_LOW_EN`. The signal level is monitored against a low-level threshold; the threshold for each channel is configured using `INx_SIG_ACT_LOW_THR` (where x indicates the channel number 1–2). If any input channel exceeds the low-level threshold, `INx_SIG_ACT_LOW_INT` is set. In a typical application, the host polls `INx_SIG_ACT_LOW_INT` to determine if the input channels have been idle for a required duration, before selecting the low-power PMIC state.

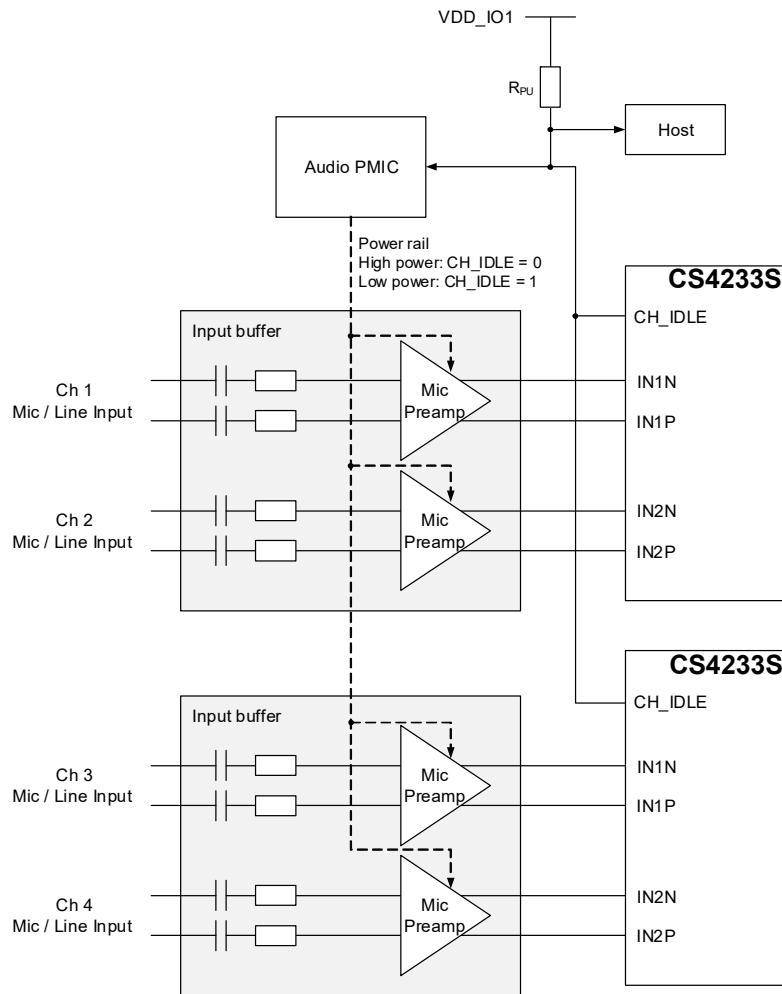
Active detection is enabled using `IN_SIG_ACT_HIGH_EN`. The signal level is monitored against a high-level threshold; the high-level threshold for each channel is configured using `INx_SIG_ACT_HIGH_THR`. If any input channel exceeds the high-level threshold `INx_SIG_ACT_HIGH_INT` is set, the CH\_IDLE pin is driven low (Logic 0), and signal-activity detection is disabled (`IN_SIG_ACT_LOW_EN` and `IN_SIG_ACT_HIGH_EN` are cleared).

Signal activity detection provides input to the interrupt controller, described in Section 4.12. `INx_SIG_ACT_HIGH_INT` and `INx_SIG_ACT_LOW_INT` are latching fields which, once set, remain set until a 1 is written to the respective bit; these bits can be polled at any time or in response to the interrupt being asserted.

Signal detection uses an averaged signal level. The averaged signal level is calculated using an exponential moving average (EMA) function; the time constant is configurable using `IN_TM_LD_TIME`. Note that these fields are also associated with the transient mask function (see Section 4.7).

The CH\_IDLE pin is an open-drain output, enabling multiple devices to drive the Logic 0 condition in a Wired-OR configuration. The host can monitor the CH\_IDLE status to determine status of the ADC input channels.

Typical connections are shown in Fig. 4-4.



**Figure 4-4. Signal Activity Detection**

### 4.5.3 ADC Digital Volume and Mute

The ADC signal path incorporates a digital volume control, supporting a gain range of  $-127.5$  dB to  $+30$  dB in  $0.5$  dB steps. Volume ramping and digital mute is also supported.

The digital volume is configured using `INx_VOL` for the respective input channel. The digital mute is enabled by setting `INx_MUTE`.

Writing to the volume or mute fields has no effect on the signal path until a 1 is written to `IN_VU`. Writing 1 to `IN_VU` causes the volume and mute settings to be updated on all input paths simultaneously.

When the volume or mute is changed, the digital gain of the affected signal paths is ramped up or down to the new setting. For increasing gain, the rate is controlled by `IN_RAMP_RATE_INC`; for decreasing gain, the rate is controlled by `IN_RAMP_RATE_DEC`.

**Note:** The `IN_RAMP_RATE_INC` and `IN_RAMP_RATE_DEC` fields should not be changed while a volume ramp is in progress.

## 4.5.4 Input Path Analog and Digital Gain

The ADC signal path incorporates analog gain, minimizing external component requirements. The analog gain enhances overall system efficiency and performance by delivering superior input-referred noise and maintaining signal integrity between different applications.

The analog gain is configurable to 0 dB, 6 dB, or 12 dB. The maximum differential input signal level at each gain setting is shown in [Table 4-9](#).

**Table 4-9. Maximum Input Signal Level per Internal Analog Gain Setting**

Internal Analog Gain (dB)	Maximum Input Signal Level ( $V_{RMS}$ )
0	2
6	1
12	0.5

The ADC path incorporates digital gain, supporting a range of –32 dB to +31.875 dB in 0.125 dB steps. The digital gain provides fine adjustment of the overall input path gain, optimizing the dynamic range of the signal path across a wide range of signal levels.

### 4.5.4.1 Gain Control

Zero-cross detection is used to synchronize the analog and digital gain changes, avoiding audible gain-change transients.

The analog gain is configured for each channel using the respective `INx_INT_ANA_GAIN` bit (where x indicates the channel number 1–2). By default, both channels are enabled with 0 dB gain.

The digital gain is configured for each channel using `INx_INT_DIG_GAIN`. Gain ramping is also supported (as described in [Section 4.7](#)).

The gain changes are applied upon register write using `INx_UPDATE`.

**Note:** The digital volume and digital gain are configured separately. The total digital gain of the input path is the sum of the digital volume and digital gain. Digital volume is described in [Section 4.5.3](#).

## 4.5.5 Input Clip Warning

The CS4233S provides a clip-warning function on the ADC input paths; this can be used to provide a warning of large or clipped signal levels.

The clip-warning threshold level is configured using `IN_CLIP_THRESH`. The selected level applies to both input channels.

Clip warning provides input to the interrupt controller (see [Section 4.12](#)). If an input signal exceeds the clip-warning threshold, the `INx_CLIP_WARN_INT` bit is set (where x indicates the channel number 1–2). These bits are latching fields which, once set, remain set until a 1 is written to the respective bits; these bits can be polled at any time or in response to the logic output signal being asserted.

## 4.5.6 Virtual PAD

The CS4233S includes a virtual PAD function that emulates a conventional PAD with minimal impact on the noise floor; this reduces external component requirements, leading to a more compact and efficient design.

If virtual PAD is used, an external preamplifier attenuates the input signal, emulating a PAD-on status. To emulate a PAD-off status, corresponding gain is applied to compensate for the external attenuation. This architecture ensures a consistent anti-aliasing filter response in either state.

A logic input to a GPIO pin can be used to select PAD-on/off status. In software mode, the PAD-on/off status can also be selected by writing to control registers via the applicable control interface.

If a logic input to a GPIO pin is used to select PAD-on/off status, edge or level detection is supported.

- If edge detection is selected, a rising-edge input on a GPIO pin toggles the PAD-on/off status for each channel. The PAD-on/off status for each channel is provided as a logic output on a GPIO pin; this can be used, for example, to control LEDs for visual indication. The Logic 1 output indicates the PAD-off status; the Logic 0 output indicates the PAD\_on status.
- If level detection is selected, a Logic 1 input on a GPIO pin selects PAD-off status and a Logic 0 input selects PAD-on status; a logic output is not provided. The logic levels are described in [Table 3-11](#).

**Note:** The GPIO logic levels are referenced to the VDD\_IO2 domain; level shifting may be required if connecting to a host interface operating at a different level (see [Table 3-11](#) for details).

Virtual PAD is supported in hardware and software modes.

#### 4.5.6.1 Hardware Mode

In hardware mode, the virtual PAD function supports a fixed external attenuation of 20 dB. The CS4233S analog and digital gains are configured to provide +20 dB gain if PAD-off status is selected and 0 dB gain if PAD-on status is selected.

**Note:** Virtual PAD is only supported in hardware mode if the system clock is sourced from MCLK.

Edge or level detection is configured using the CONFIG 4 pin, as shown in [Table 4-3](#).

If edge detection is selected, the GPIO pins as assigned as described in [Table 4-10](#).

**Table 4-10. Virtual PAD Edge Detection GPIO Configuration**

Pin Number	Pin Name	Function
14	GPIO1	Channel 1 output
15	GPIO2	Channel 2 output
17	GPIO3	Channel 1 input
18	GPIO4	Channel 2 input

If level detection is selected, the GPIO pins are assigned as described in [Table 4-11](#).

**Table 4-11. Virtual PAD Level Detection GPIO Configuration**

Pin Number	Pin Name	Function
14	GPIO1	DAC shutdown input
15	GPIO2	—
17	GPIO3	Channel 1 input
18	GPIO4	Channel 2 input

**Note:** If edge detection is selected, the DAC shutdown function is not available. For further details on DAC shutdown refer to [Section 4.6.5](#).

#### 4.5.6.2 Software Mode

In software mode, the virtual PAD function supports a configurable external preamplifier gain; for PAD-on, a maximum attenuation of 20 dB is supported. HGC synchronizes adjustments across the combined external and internal gain range (HGC operation is described in [Section 4.7](#)).

- To emulate PAD-off status, the external analog gain is configured for each channel using [INx\\_HIGH\\_EXT\\_ANA\\_GAIN](#), and the internal analog and digital gains are configured for each channel using [INx\\_HIGH\\_INT\\_ANA\\_GAIN](#) and [INx\\_HIGH\\_INT\\_DIG\\_GAIN](#) respectively (where x indicates the channel number 1–2).
- To emulate PAD-on status, the external analog gain is configured for each channel using [INx\\_LOW\\_EXT\\_ANA\\_GAIN](#), and the internal analog and digital gains are configured using [INx\\_LOW\\_INT\\_ANA\\_GAIN](#) and [INx\\_LOW\\_INT\\_DIG\\_GAIN](#) respectively.

The external analog gain can be controlled using the HGC SPI control interface or by logic level output on GPIO pins; HGC SPI or GPIO control is selected using [HGC\\_CTRL\\_INTERFACE](#). If the HGC SPI control interface is selected, GPIO functions are not supported on the HGC\_CS/GPIO2, XTAL\_IN/HGC\_SDO/GPIO3, and XTAL\_OUT/HGC\_SKC/GPIO4 pins,

If the HGC SPI control interface is selected, the bit patterns corresponding to the external gain selections are configured for each channel using the respective [INx\\_HIGH\\_BIT\\_PATT](#) and [INx\\_LOW\\_BIT\\_PATT](#) fields. If GPIO control is selected, the GPIO1–4 pin output levels are configured using bits 12–15 respectively of [INx\\_HIGH\\_BIT\\_PATT\\_1](#) and [INx\\_LOW\\_BIT\\_PATT\\_1](#).

**Note:** The [INx\\_HIGH\\_BIT\\_PATT](#) and [INx\\_LOW\\_BIT\\_PATT](#) bit patterns are a maximum of 32 bits. The bit pattern length is configured for each channel using [INx\\_BIT\\_PATT\\_LENGTH](#), the selected length applies to both bit patterns. If the bit pattern is 16 bits or less, it is stored in the [INx\\_HIGH\\_BIT\\_PATT\\_1](#) and [INx\\_LOW\\_BIT\\_PATT\\_1](#) fields. The MSB represents the first-transmitted bit of the pattern; one or more of the LSBs may be unused, depending on the size of the bit pattern. If the bit pattern is more than 16 bits, the remaining bits are stored in [INx\\_HIGH\\_BIT\\_PATT\\_0](#) and [INx\\_LOW\\_BIT\\_PATT\\_0](#).

The internal and external gain configuration settings do not take effect until the PAD-on/off status is selected. PAD-off status can be selected by writing 1 to [INx\\_HIGH\\_UPDATE](#); PAD-on status can be selected by writing 1 to [INx\\_LOW\\_UPDATE](#).

PAD-on/off selection provides input to the interrupt controller, described in [Section 4.12](#). If [INx\\_HIGH\\_UPDATE](#) and [INx\\_LOW\\_UPDATE](#) are set concurrently (i.e., PAD-on status and PAD-off status are both selected simultaneously), an interrupt event is indicated using [GAIN\\_CONFLICT\\_INT](#). This is a latching bit which, once set, remains set until a 1 is written. This bit can be polled at any time or in response to the interrupt being asserted.

The PAD-on/off status can be selected by a logic input to a GPIO pin; the pin is selected using the respective [INx\\_GPI\\_SEL](#) bits. Edge or level detection (described in [Section 4.5.6](#)) is configured using [SW\\_TYPE](#).

- If edge detection is selected, the debounce time is configurable using [DB\\_TIME](#).
- If level detection is selected, a Logic 1 input selects PAD-off status and a Logic 0 input selects PAD-on status; the input polarity can be inverted for each channel using the respective [INx\\_GPI\\_POL](#) bits.

The PAD-on/off status for each channel can be configured as a logic output on a GPIO pin; the pin is selected using the respective [INx\\_GPO1\\_SEL](#) to [INx\\_GPO4\\_SEL](#) bits. For PAD on status, the output logic levels for pins GPIO1–4 are configured using bits 12–15 respectively of [INx\\_LOW\\_BIT\\_PATT\\_1](#); for PAD off status, the output logic levels for pins GPIO1–4 are configured using bits 12–15 respectively of [INx\\_HIGH\\_BIT\\_PATT\\_1](#). Note that if one or more GPIO pins are used to control external gain, the same GPIO pins cannot be used for virtual PAD functions.

**Notes:** Pins GPIO3 and GPIO4 are not available if the system clock is sourced from the crystal oscillator.

The GPIO logic levels are referenced to the VDD\_IO2 domain; level shifting may be required if connecting to a host interface operating at a different level (see [Table 3-11](#) for details).

The current status for each GPIO pin is indicated using [GPI\\_STS](#) and [GPO\\_STS](#). If the input polarity is inverted (i.e., the [INx\\_GPI\\_POL](#) bits are set), the [GPI\\_STS](#) bits indicate the opposite logic level to the GPIO pin status.

### 4.5.6.3 Automatic PAD Response

In software mode, the virtual PAD function incorporates a level detector on the ADC input channels to selectively determine whether the PAD should be turned on. This can be used to prevent clipping of large signals at the ASP output without requiring host intervention. The level detector is enabled on each audio channel using the respective [INx\\_PAD\\_LD\\_EN](#) bit (where x indicates the channel number 1–2).

The high and low thresholds associated with the virtual PAD level detector are configured using [INx\\_PAD\\_HIGH\\_THR](#) and [INx\\_PAD\\_LOW\\_THR](#) respectively.

Signal detection for the high-level threshold uses either the instantaneous or averaged signal level; this is selected using [IN\\_PAD\\_LD\\_AVG](#). Signal detection for the low-level threshold uses the averaged signal level. The averaged signal level is calculated using an exponential moving average (EMA) function; the time constant is configurable using [IN\\_PAD\\_LD\\_TIME](#).

If the input signal exceeds the high-level threshold, the CS4233S can automatically select PAD-on status. Automatic PAD response is enabled using `INx_PAD_AUTO_EN`. Note that PAD-on status remains selected until PAD-off is selected by a Logic 1 input to a GPIO pin or by writing 1 to `INx_HIGH_UPDATE`.

Automatic PAD response provides input to the interrupt controller, described in [Section 4.12](#). If the input signal exceeds the low-level threshold, the `INx_PAD_LOW_INT` bit is set. If the input signal exceeds the high-level threshold, the `INx_PAD_HIGH_INT` bit is set. These bits are latching fields which, once set, remains set until a 1 is written. These bits can be polled at any time or in response the interrupt being asserted; the host can use these bits to determine whether to turn the PAD-on, or to turn the PAD-off (including after an automatic response).

## 4.6 DAC and Analog Output

The CS4233S supports up to two analog output channels, each incorporating a high-performance sigma-delta digital-to-analog converter (DAC). Digital volume and mute control is provided on each output channel.

The digital volume and mute controls are supported in software (I<sup>2</sup>C/SPI) control mode only. In hardware control mode, all channels are enabled with 0 dB volume.

### 4.6.1 DAC Path Enable

The analog outputs and DAC paths are enabled using `OUTx_DAC_EN` (where x indicates the channel number 1–2).

When the output paths are enabled for the first time after power-up or after the DAC reference has been disabled (described in [Section 4.6.5](#)), the paths do not become active until a startup delay has elapsed; the delay ensures the noise floor of the output path has settled before it becomes active and mitigates any audible artifacts. The time delay (1 s) is applied when the output paths are enabled using `OUTx_DAC_EN`.

The polarity of the DAC output can be inverted using `OUTx_INV` for the respective channel.

The CS4233S supports a mono output configuration; this can be used in applications where stereo sound is unnecessary, such as voice playback, alarms, or devices with a single speaker. If mono operation is required, it is recommended to configure the CS4233S with a single output path enabled prior to initial startup to minimize any audible artifacts.

### 4.6.2 DAC Digital Volume and Mute

The DAC signal path incorporates a digital volume control, supporting a gain range of –127.5 dB to 0 dB in 0.5 dB steps. Volume ramping and digital mute is also supported.

The digital volume is configured using `OUTx_VOL` for the respective output channel. The digital mute is enabled by setting `OUTx_MUTE`.

Writing to the volume or mute fields has no effect on the signal path until a 1 is written to `OUT_VU`. Writing 1 to `OUT_VU` causes the volume and mute settings to be updated on all output paths simultaneously.

When the volume or mute is changed, the gain of the affected signal paths is ramped up or down to the new setting. For increasing gain, the rate is controlled by `OUT_RAMP_RATE_INC`; for decreasing gain, the rate is controlled by `OUT_RAMP_RATE_DEC`.

**Note:** The `OUT_RAMP_RATE_INC` and `OUT_RAMP_RATE_DEC` fields should not be changed while a volume ramp is in progress.

### 4.6.3 DAC Digital Gain

The DAC signal path incorporates digital gain, supporting a range of –32 dB to +31.875 dB in 0.125 dB steps. The digital gain provides fine adjustment of the overall output path gain. The digital gain is configured for each channel using `OUTx_DIG_GAIN`. Gain ramping is also supported (as described in [Section 4.7](#)).

The gain changes are applied upon register write using `OUTx_UPDATE`.

**Note:** The digital volume and digital gain are configured separately. The total digital gain of the output path is the sum of the digital volume and digital gain.

#### 4.6.4 DAC Power Optimization

A Class A amplifier is provided in the DAC output path to convert the current output to a voltage output. An external feedback circuit is required, as described in [Section 5.2](#).

A voltage output of  $2 V_{RMS}$  is provided; this supports a minimum resistive load of  $3\text{ k}\Omega$  in parallel with a maximum capacitive load of  $100\text{ pF}$ . If the load has a higher-impedance, the CS4233S can optimize power consumption by adjusting the drive current while maintaining an output of  $2 V_{RMS}$ . In this case, a minimum resistive load of  $10\text{ k}\Omega$  in parallel with a maximum capacitive load of  $100\text{ pF}$  is supported.

The maximum load impedance is selected using [OUT\\_LOAD\\_CFG](#).

#### 4.6.5 DAC Shutdown

To minimize power consumption when all output paths are disabled, the DAC reference circuit can be disabled. Note that power consumption is only reduced if the output paths have previously been enabled. Until they are enabled for the first time, the power consumption is already minimized.

In software mode, the DAC reference circuit is disabled using [DAC\\_SHUTDOWN](#). If this bit is set, all paths are disabled regardless of the status of the [OUTx\\_DAC\\_EN](#) bits. Prior to disabling the DAC reference circuit, it is recommended to mute the output paths, as described in [Section 4.6.2](#).

**Note:** If the [DAC\\_SHUTDOWN](#) bit is cleared, any output paths where [OUTx\\_DAC\\_EN](#) is set are enabled.

In hardware mode, the DAC shutdown function incorporates a controlled shutdown sequence to mitigate any audible artifacts. The shutdown sequence slowly ramps down the digital volume and then ramps down the DAC output voltage prior to disabling the DAC reference circuit.

The shutdown sequence is selected using a rising-edge logic input on the GPIO1 pin. GPIO1 must be held low (i.e., Logic 0) during device startup.

**Note:** If CONFIG4 is configured to enable virtual PAD edge detection (refer to [Table 4-3](#)), GPIO1 functions as a GPIO output. In this case, the DAC shutdown function is not available in hardware mode. For further details on virtual PAD see [Section 4.5.6](#).

To enable the DAC reference circuit after a hardware shutdown, the  $\overline{\text{RESET}}$  pin must be asserted (Logic 0), or the device power cycled.

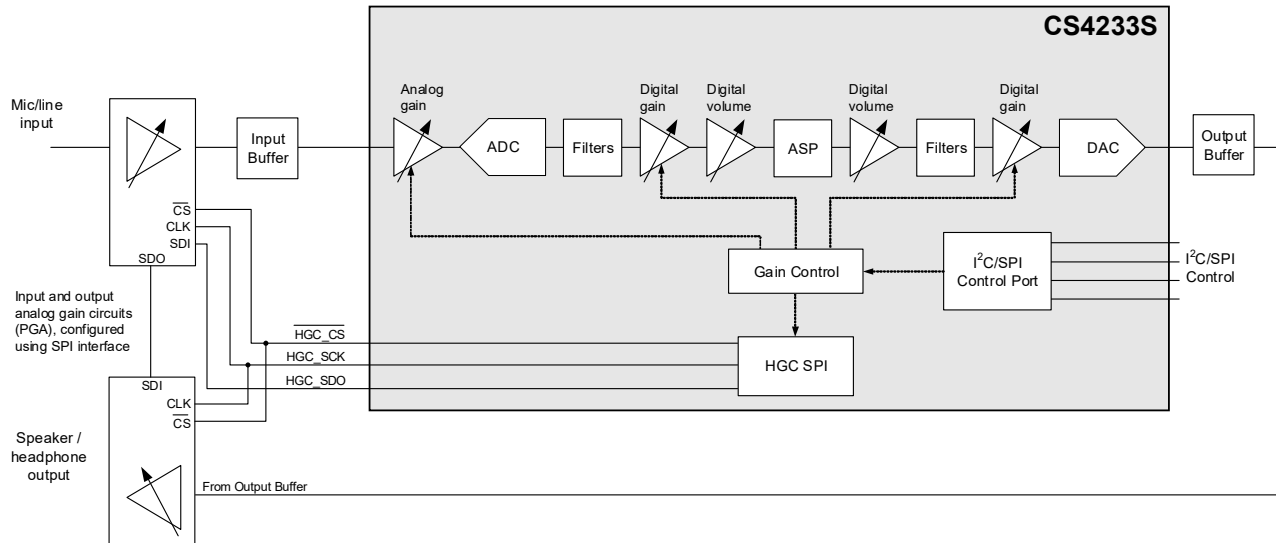
### 4.7 Hybrid Gain Control

The CS4233S provides the capability to independently or simultaneously control external gain stages associated with the ADC input path and the DAC output path. In typical applications, a separate gain control manages the external gain changes. The hybrid gain control (HGC) function enables synchronized adjustments across the combined external and internal gain range; this enables fine-resolution gain changes without audible artifacts due to external gain step changes.

A configurable transient-masking function is integrated with the input path gain-control circuits; this enables seamless gain adjustment by actively suppressing the switching transients often associated with the input analog gain selection.

The external analog gain can be controlled by the CS4233S using the HGC SPI control interface implemented on the  $\overline{\text{HGC\_CS}}$ ,  $\overline{\text{HGC\_SCK}}$ , and  $\overline{\text{HGC\_SDO}}$  pins, as illustrated in [Fig. 4-5](#). The HGC SPI control interface is not available if the system clock is supplied using the crystal oscillator.

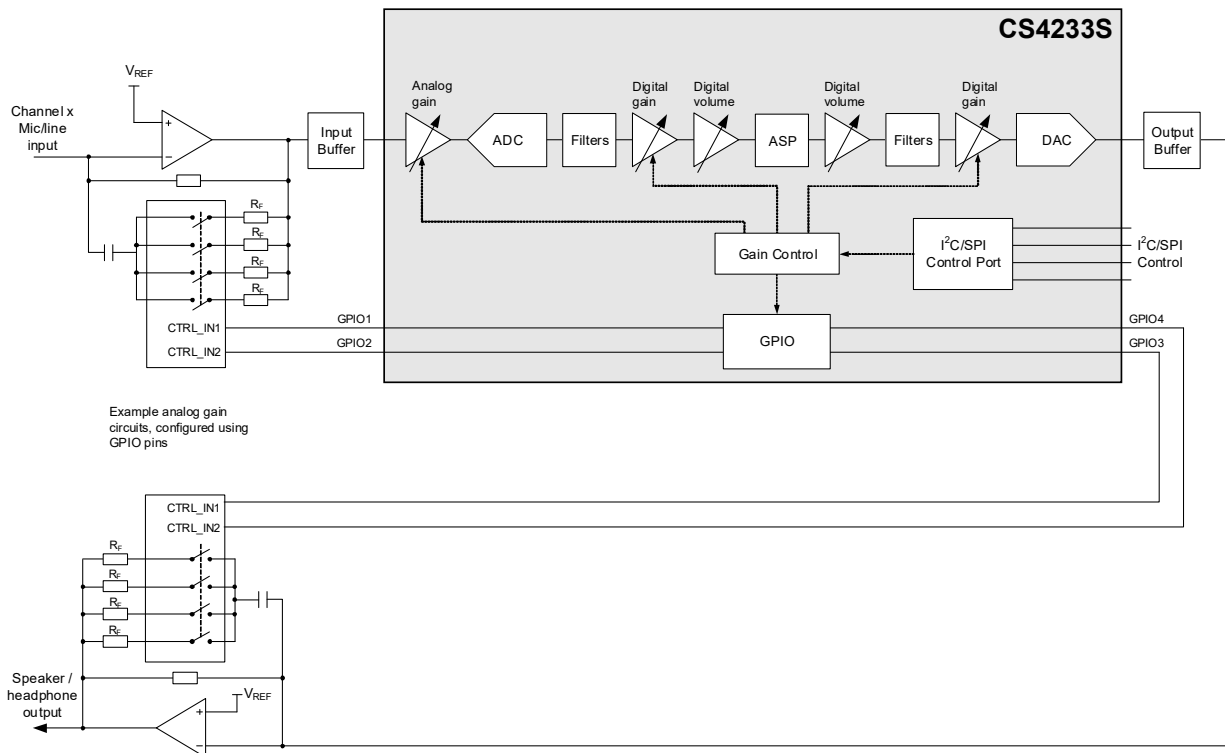
**Note:** If the HGC SPI control interface is selected, GPIO functions are not supported on the GPIO2, GPIO3, GPIO4 pins.



**Figure 4-5. Hybrid Gain Control using HGC SPI**

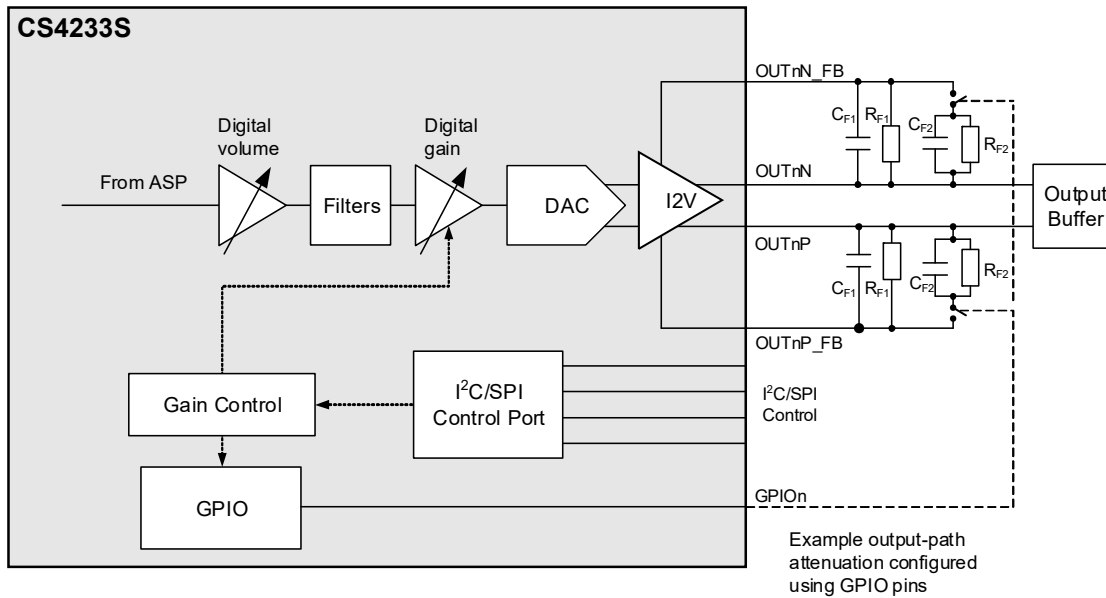
Alternatively, the GPIO pins can be configured to control the external analog gain; an example using GPIO1 and GPIO2 for the input path gain, and GPIO3 and GPIO4 for the output path gain is shown in Fig. 4-6. The control type, SPI (default) or GPIO, is selected using [HGC\\_CTRL\\_INTERFACE](#).

**Note:** GPIO3 and GPIO4 are not available if the system clock is supplied using the crystal oscillator.



**Figure 4-6. Hybrid Gain Control using GPIO Pins**

The HGC function can be used to attenuate the output path; an example using GPIO pins is illustrated in Fig. 4-7.



**Figure 4-7. Example of Output Path Attenuation using GPIO Pins**

To configure the signal path, the host processor writes gain control data to the CS4233S. If the HGC SPI interface has been selected, the CS4233S forwards the data to the external analog gain stage; if the GPIOs have been selected, the CS4233S configures the required GPIO output logic levels. If HGC SPI control is used, multiple external analog gain stages can be independently controlled in a configurable daisy-chain arrangement, as described in Section 4.7.1.

Zero-cross detection is used to synchronize the external gain configuration with the input/output signal and with the internal gain configurations ensuring seamless operation across the combined gain range.

Volume ramping is supported on the digital volume (see Section 4.5.3 and Section 4.6.2); the volume ramp is coordinated with the internal and external gain controls, enabling smooth transitions across the full range of the internal and external gain selections.

**Note:** The digital volume and digital gain are configured separately. The total digital gain of the output path is the sum of the digital volume and digital gain.

The HGC SPI controller interface can also be used to control auxiliary functions associated with the input/output path using a port expander or similar external IC.

### 4.7.1 HGC SPI Controller Interface Configuration

The HGC SPI controller interface is supported using the  $\overline{\text{HGC\_CS}}$ /GPIO2, XTAL\_IN/HGC\_SDO/GPIO3, and XTAL\_OUT/HGC\_SCK/GPIO4 pins, which must be configured for the SPI function if required. The HGC SPI function is selected using  $\overline{\text{HGC\_CTRL\_INTERFACE}}$ . The interface comprises three connections as follows:

- HGC\_SCK = Clock output
- HGC\_SDO = Data output
- $\overline{\text{HGC\_CS}}$  = Chip select ( $\overline{\text{CS}}$ ), active low

**Note:** The HGC SPI interface connections are powered by VDD\_IO2; see Table 3-11 for digital I/O levels.

The CS4233S configures the external analog gain circuits using a bit pattern that is transmitted to each of the connected devices in a daisy-chain manner. The bit pattern is shifted through each of the connected devices according to a configurable position in the chain, allowing each device to be individually controlled via a shared data interface.

The HGC SPI interface is fully configurable and flexible to support a wide variety of external gain-control implementations. The HGC SPI data definition is not fixed on the CS4233S; the HGC SPI data can be configured to support whatever bit patterns are required in the specific application.

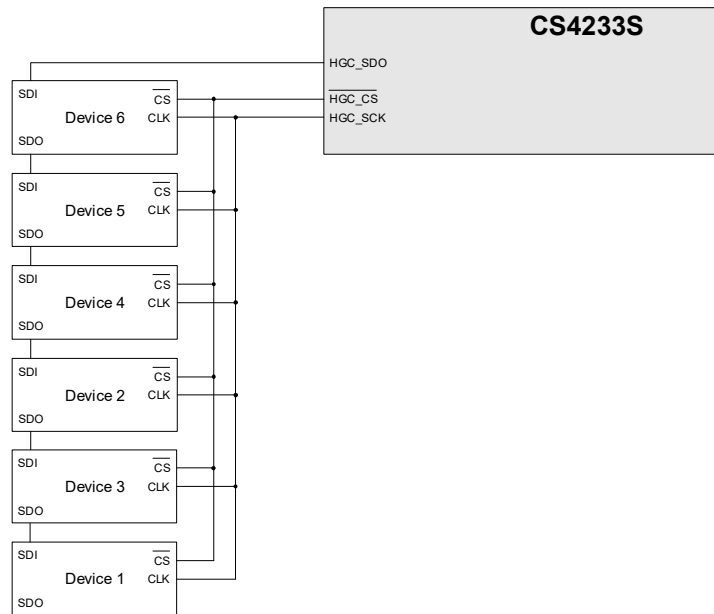
A maximum of six devices can be controlled, including two auxiliary devices, as described in [Section 4.7.7](#). The number of bits associated with each connected device is configured for the respective audio channel using [INx\\_BIT\\_PATT\\_LENGTH](#), [OUTx\\_BIT\\_PATT\\_LENGTH](#), and for the auxiliary devices using [AUXx\\_BIT\\_PATT\\_LENGTH](#).

Each connected device is allocated a position in the daisy chain using the respective [INx\\_SPI\\_POSITION](#), [OUTx\\_SPI\\_POSITION](#), and [AUXx\\_SPI\\_POSITION](#) bits. The devices must be assigned to consecutive positions, starting with position 000. The daisy-chain wiring of the external devices must be in the same order as the allocated positions; this ensure each device is configured with its corresponding bit pattern.

The bit pattern length and device position bits should be set to 0 for any audio channel where there is no associated device to be controlled.

If the bit pattern or the device position bits are updated, the new settings are latched internally and are not reflected in the HGC SPI data output until a 1 is written to [HGC\\_INIT\\_UPDATE](#). The host processor must confirm that the gain controller is idle ([HGC\\_BUSY\\_STS](#) = 0) before writing to [HGC\\_INIT\\_UPDATE](#).

Example connections are shown in [Fig. 4-8](#).



**Figure 4-8. HGC SPI Daisy Chain Example Connections**

In this example, Device 1 and Device 3 are connected to input channels 1 and 2 respectively, Device 2 and Device 4 are connected to output channels 1 and 2 respectively, and there are two auxiliary devices, Device 5 and Device 6. The order that the devices are to be serviced in, i.e., the order that they are connect in the daisy chain is Device 1, Device 3, Device 2, Device 4, Device 5, and Device 6. The device positions are configured as shown in [Table 4-12](#).

**Table 4-12. Example SPI Position Configuration**

Device	Position	Configuration
Device 1	1	IN1_SPI_POSITION = 000
Device 2	3	OUT1_SPI_POSITION = 010
Device 3	2	IN2_SPI_POSITION = 001
Device 4	4	OUT2_SPI_POSITION = 011
Device 5	5	AUX1_SPI_POSITION = 100
Device 6	6	AUX2_SPI_POSITION = 101

The HGC SPI controller is configurable to support different timing and signal-polarity options. The `HGC_CLK_POL` bit controls the polarity of the clock output; the `HGC_CLK_PHA` bit controls which phase of the clock cycle the data output is valid. See [Table 3-18](#) for timing specifications.

The HGC SPI clock rate is derived as an integer division of the system clock. The HGC SPI clock rate is configured using `HGC_SCK_DIV`, supporting divisors of 512 fs(base) or 1024 fs(base); where fs(base) = 48 kHz (for 48 kHz-related sample rates), or 44.1 kHz (for 44.1 kHz-related sample rates). The fastest HGC SPI clock is 12.288 MHz or 11.2896 MHz, depending on sample rate. Slower clock rates can be used to ensure correct timing of the bus signals in applications where a large load capacitance is connected to the HGC SPI outputs.

The minimum idle period between HGC SPI transactions is configured using `HGC_CSB_IDLE_DUR`. The delay between the falling  $\overline{CS}$  edge and the first SCK edge is configured using `HGC_CSB_FALL_DLY`. The minimum delay between the last SCK edge and the rising  $\overline{CS}$  edge is configured using `HGC_CSB_RISE_DLY`.

In normal operation, the timing of the rising  $\overline{CS}$  edge is controlled automatically by the zero-cross detection; the `HGC_CSB_RISE_DLY` field determines the minimum delay.

## 4.7.2 GPIO Configuration

External gain control using GPIO output is supported using pins GPIO1, HGC\_CS/GPIO2, XTAL\_IN/HGC\_SDO/GPIO3, and XTAL\_OUT/HGC\_SCK/GPIO4, which must be configured for GPIO use if required. External gain configuration using the GPIO output is selected using `HGC_CTRL_INTERFACE`.

The GPIO pins are configured as outputs for the input channels using `INx_GPO1_SEL` to `INx_GPO4_SEL` and for the output channels using `OUTx_GPO1_SEL` to `OUTx_GPO4_SEL` (where x indicates the channel number 1–2). Pins GPIO3 and GPIO4 are not available if the system clock is supplied by the crystal oscillator.

The GPIO pins are powered by VDD\_IO2; see [Table 3-11](#) for digital I/O levels.

## 4.7.3 Input Path Gain Control Optimization

The CS4233S provides tunable input path parameters to minimize any audible artifacts when changing the gain configuration. After configuring the external gain, by clocking out the HGC SPI bit pattern or configuring the required GPIO control fields, the CS4233S waits for a zero-cross point in the affected audio channel before completing the HGC SPI transaction (by deasserting the  $\overline{CS}$  signal) or updating the GPIO output logic levels. This ensures the gain change is aligned with a zero-cross point on the input signal, on the assumption that deasserting the  $\overline{CS}$  (Logic 1) or configuring the GPIO output logic levels causes the new gain setting to be applied immediately in the external circuit. A timeout for zero-cross detection is configured using `IN_ZC_TIMEOUT`.

After the external gain is updated, the CS4233S waits for a configurable delay before completing the internal analog gain change. The delay is used to align the internal analog gain update with the external analog gain update in the audio stream. The internal analog delay is configured using `IN_INT_ANA_GAIN_DLY`; this field should be set to equal the total external input path delay (i.e., external input analog gain circuit + input buffer) even if no internal analog gain change is required. The delay should be rounded down for the purposes of selecting the nearest `IN_INT_ANA_GAIN_DLY` option.

To align the digital gain update with the internal analog gain update in the audio stream, the CS4233S waits for a configurable digital gain delay before completing the internal digital gain counter step and ramp change. The digital counter step is equal to the sum of the external and internal analog gain steps. The digital gain delay is configured using `IN_INT_DIG_GAIN_DLY`; this field should be set equal to the ADC filter group delay. The ADC filter characteristics are specified in [Table 3-6](#). The delay should be rounded down for the purposes of selecting the nearest `IN_INT_DIG_GAIN_DLY` option.

A transient-masking function is available on the input path; this is enabled using `IN_TM_EN`. If enabled, the CS4233S repeats one audio sample for the duration of the transient period, masking the artifact arising from the gain change.

The `IN_TM_DLY` field defines the time from the external analog gain update to the onset of the transient masking; for typical use cases, the `IN_TM_DLY` field should be less than or equal to the `IN_INT_DIG_GAIN_DLY`. The duration of the transient period masking is configured using `IN_TM_HOLD_TIME`.

Transient masking is most effective on low-amplitude signals and is not recommended for larger signals. The CS4233S incorporates a level detector to selectively determine whether the masking should be applied. The transient-masking level detector is enabled on each audio channel using the respective `INx_TM_LD_EN` bit (where x indicates the channel number 1–2). The level detector calculates the signal level using an exponential moving average (EMA) function; the time constant is configurable using `IN_TM_LD_TIME`.

If the level detector is enabled, the threshold for transient masking is configured using `INx_TM_LD_THR`—masking is applied if the signal level is below the threshold. If the level detector is disabled, transient masking is applied regardless of the signal level.

#### 4.7.4 Output Path Gain Control Optimization

The CS4233S provides tunable output path parameters to minimize any audible artifacts when changing the gain configuration. After configuring the external gain, by clocking out the HGC SPI bit pattern or configuring the required GPIO control fields, the CS4233S pauses the external gain change (by asserting the `CS` signal or maintaining the current GPIO output logic levels). The CS4233S then completes the required internal digital gain change. The digital gain change process is dependent on whether a positive or negative external gain change is required:

- If a positive gain change is required, the CS4233S waits for a zero-cross point in the affected audio channel before completing the digital gain step and ramp.
- If a negative gain step is required, the CS4233S ramps down the digital gain and then waits for the zero-cross point in the affected audio channel before completing the digital gain step.

Gain ramping is described in [Section 4.7.6](#).

The CS4233S waits for a configurable external delay, to ensure the digital gain change has time to propagate through the DAC and any external delay (i.e., the output buffer and external amplifier), before completing the external gain change (by deasserting the `CS` signal or updating the GPIO output logic levels). This ensures the analog step is aligned with the zero-cross point, reducing any audible artifacts. The external delay is configured using `OUT_EXT_GAIN_DLY`. A timeout for zero-cross point detection is configured using `OUT_ZC_TIMEOUT`.

#### 4.7.5 Audio Channel Gain Control

The host processor configures the external analog, internal analog, and internal digital gain for each audio channel by writing to the respective `INx_EXT_ANA_GAIN`, `INx_INT_ANA_GAIN`, and `INx_INT_DIG_GAIN` and `OUTx_ANA_GAIN`, and `OUTx_DIG_GAIN` fields.

The host must also write the `INx_BIT_PATT` and `OUTx_BIT_PATT` fields to provide the bit pattern to configure the external device for the required analog gain. If the GPIOs are used, the GPIO output logic levels are determined by bits 12–15 of the `INx_BIT_PATT_1` and `OUTx_BIT_PATT_1` fields.

**Note:** The `INx_BIT_PATT` and `OUTx_BIT_PATT` bit pattern is a maximum of 32 bits (the size is configured using `INx_BIT_PATT_LENGTH` and `OUTx_BIT_PATT_LENGTH`). If the bit pattern is 16 bits or less, it is stored in the `INx_BIT_PATT_1` and `OUTx_BIT_PATT_1` field. The MSB represents the first-transmitted bit of the pattern; one or more of the LSBs may be unused, depending on the size of the bit pattern. If the bit pattern is more than 16 bits, the remaining bits are stored in `INx_BIT_PATT_0` and `OUTx_BIT_PATT_0`.

The analog and digital gain settings do not become effective immediately on updating the control fields. Writing 1 to `INx_UPDATE` and `OUTx_UPDATE` initiates the update for the respective audio channel and queues the update to be applied; the CS4233S services each updated channel in turn and applies the respective gain settings at the earliest opportunity, dependent on the zero-cross detection for each affected channel.

The `HGC_BUSY_STS` bit, if set, indicates that gain updates are pending for one or more audio channels (i.e., gain settings have been written to the CS4233S, but not yet applied to the respective audio paths). The bit is cleared automatically when all updates have been applied to the respective channels.

The gain settings, including external gain bit patterns or GPIO output level settings, for each audio channel can be written at any time, regardless of whether an earlier update is currently pending for that channel.

If an audio channel is enabled, but does not have any associated HGC SPI- or GPIO-controlled external gain circuit, the external and internal analog gain and digital gain for the respective channel must be maintained at 0 dB (default).

For efficiency of the host-processor interactions, the input path and output path bit pattern and gain fields can be written as a contiguous block (i.e., one auto-incrementing I<sup>2</sup>C/SPI write operation). The `INx_UPDATE` and `OUTx_UPDATE` bits can be set in the same I<sup>2</sup>C/SPI operation as writing to the corresponding `INx_INT_DIG_GAIN` and `OUTx_DIG_GAIN` bits.

**Note:** If the `INx_UPDATE` or `OUTx_UPDATE` bits are written 0 when updating the gains or bit-pattern fields, the settings are latched internally but the updates are not applied to the audio path and do not cause the `HGC_BUSY_STS` bit to be set. Writing 0 to `INx_UPDATE` or `OUTx_UPDATE` is used in the initialization steps described in Section 4.7.8. Prior to writing 1 to any of the `INx_UPDATE` or `OUTx_UPDATE` bits, HGC must be initialized as described in Section 4.7.8.

### 4.7.6 Gain Ramping Control

The CS4233S supports independent control of the external analog, internal analog, and digital gain stages of the input and output path. When the digital gain is updated, the gain is ramped up or down to the new value. When the external and internal analog gains are updated, the CS4233S uses digital control to provide a ramped response, masking the larger step size of the analog gain.

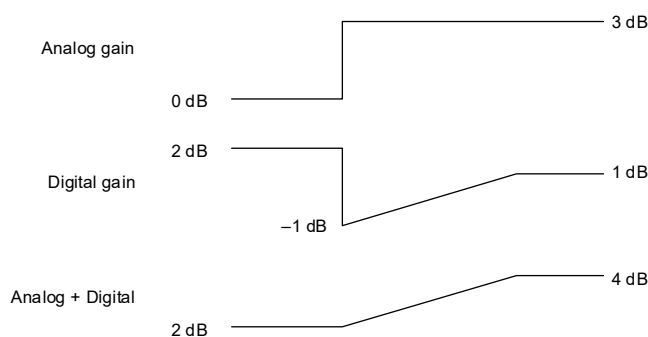
For example, if the input path external analog gain is increased by 3 dB, the gain step is initially canceled out by decreasing the digital gain by -3 dB. Following this, the digital gain is smoothly ramped up by 3 dB to give the desired overall gain; if the output path external analog gain is decreased by -3 dB, the digital gain is smoothly ramped up by 3 dB gain. Following this the analog gain increase is canceled out by decreasing the digital gain by -3 dB.

Gain ramping is supported for changes in analog gain up to a maximum step size of ±32 dB. The digital adjustment used to cancel the initial analog step is supported using a combination of the digital gain and digital volume functions.

Note there is no restriction on whether the external and internal gains are updated in the same operation—the gain ramping is supported for all combinations.

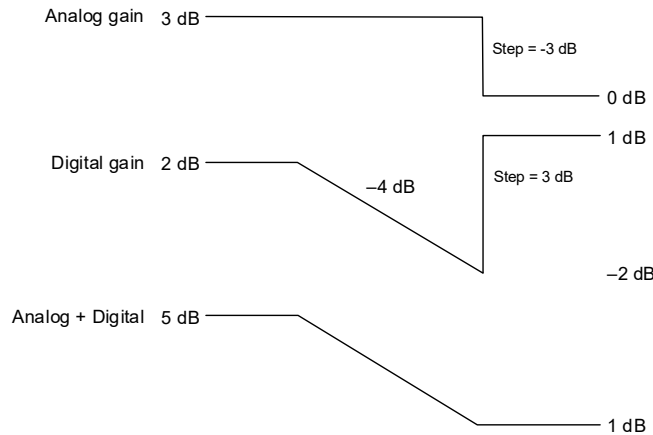
The gain ramping is illustrated in Fig. 4-9 and Fig. 4-10.

In Fig. 4-9, the initial input path overall gain is 2 dB and a gain of 4 dB is required. The total external plus internal analog gain is updated by +3 dB from 0 dB to 3 dB. The digital gain is initially set to -1 dB, providing the -3 dB counter step to the analog gain step, and then ramped to +1 dB. This gives a smooth transition from 2 dB to 4 dB in the overall (analog + digital) response.



**Figure 4-9. Input Path Positive Gain Ramping**

In Fig. 4-10, the initial output path overall gain is 5 dB and an overall gain of 1 dB is required. The external analog gain is updated by -3 dB from 3 dB to 0 dB. The digital gain ramps down by 4 dB from 2 dB to -2 dB and then steps up by +3 dB, providing the analog counter step. This gives a smooth transition from 5 dB to 1 dB in the overall (analog + digital) response,



**Figure 4-10. Output Path Negative Gain Ramping**

The digital gain counter step and ramp response is configured using `IN_STEP_RAMP_EN` and `OUT_STEP_RAMP_EN`. If this bit is set, the CS4233S applies the digital gain counter step to mask the analog gain steps. If this bit is clear, there is no masking of the analog gain steps.

For increasing gain, the ramp rate is controlled by `IN_RAMP_RATE_INC` and `OUT_RAMP_RATE_INC`; for decreasing gain, the rate is controlled by `IN_RAMP_RATE_DEC` and `OUT_RAMP_RATE_DEC`.

**Notes:** If the digital gain ramping is enabled, (`IN_STEP_RAMP_EN` = 1 or `OUT_STEP_RAMP_EN` = 1), the volume increasing/decreasing ramp rates must be set to nonzero values. See Section 4.5.3 and Section 4.6.2 to configure the volume ramp rates.

The `IN_RAMP_RATE_INC` and `OUT_RAMP_RATE_INC` and `IN_RAMP_RATE_DEC` and `OUT_RAMP_RATE_DEC` fields should not be changed while a volume ramp is in progress.

### 4.7.7 Auxiliary Device Control

Auxiliary device control is supported if the HGC SPI control interface is used, for details refer to Section 4.7.1. The host processor configures the auxiliary devices by writing to the respective `AUXx_BIT_PATT` fields. Each field contains the bit pattern to configure the respective external device as required.

**Note:** The bit pattern is a maximum of 32 bits (the size is configured using `AUXx_BIT_PATT_LENGTH`). If the bit pattern is 16 bits or less, it is stored in the `AUXx_BIT_PATT_1` field. The MSB represents the first-transmitted bit of the pattern; one or more of the LSBs may be unused, depending on the size of the bit pattern. If the bit pattern is more than 16 bits, the remaining bits are stored in `AUXx_BIT_PATT_0`.

If the auxiliary bit patterns are updated, the new settings are latched internally and are not reflected in the SPI data output until a 1 is written to `HGC_INIT_UPDATE`. The host processor must confirm that the gain controller is idle (`HGC_BUSY_STS` = 0) before writing to `HGC_INIT_UPDATE`.

### 4.7.8 Initialization

Hybrid gain control must be initialized to ensure correct gain-ramping behavior. The host processor should configure the bit patterns and all gain fields for all channels—writing `INx_UPDATE` = 0 and `OUTx_UPDATE` = 0 separately, for each audio channel—and then write 1 to `HGC_INIT_UPDATE` to transmit the bit patterns and initialize the internal gain-control

algorithms. If a pending update ( $INx\_UPDATE = 1$  or  $OUTx\_UPDATE = 1$ ) is superseded by another update ( $INx\_UPDATE = 0$  or  $OUTx\_UPDATE = 0$ ), the former is ignored. Note that the host processor must confirm that the gain controller is idle ( $HGC\_BUSY\_STS = 0$ ) before writing to  $HGC\_INIT\_UPDATE$ .

**Note:** There is no zero-cross detection or transient masking when using  $HGC\_INIT\_UPDATE$ , so audible artifacts may occur. It is recommended to mute all audio channels (using  $INx\_MUTE$  and  $OUTx\_MUTE$ ) to suppress any unintended transients.

Writing to  $HGC\_INIT\_UPDATE$  has no effect if  $HGC\_BUSY\_STS = 1$ , indicating that gain updates are pending for one or more audio channels. The host processor can cancel any pending gain updates by writing 1 to  $HGC\_ABORT$ —this can be used to return the controller to the idle state as quickly as possible, in readiness for initializing the system with a new configuration.

If the  $HGC\_ABORT$  bit is written, the CS4233S does not become idle until it has finished applying the updates to the audio channel currently being processed. The host processor must always check the controller is idle ( $HGC\_BUSY\_STS = 0$ ) before writing to  $HGC\_INIT\_UPDATE$ .

**Note:** Any gain updates that are canceled using the  $HGC\_ABORT$  bit may result in an inconsistency between the register map and the respective gain settings. The  $HGC\_ABORT$  bit should only be used as part of a control sequence that also uses  $HGC\_INIT\_UPDATE$  to apply a new configuration to all channels.

### 4.7.9 HGC Interrupts

The HGC function provides inputs to the interrupt controller, as described in [Section 4.12](#). An interrupt is triggered if any of the following interrupt bits are set:

- $HGC\_SPI\_ERROR\_INT$ : indicates an invalid (zero-length) SPI transaction
- $HGC\_ABORT\_ERROR\_INT$ : the HGC operation has been aborted using the  $HGC\_ABORT$  bit
- $HGC\_ERROR\_INT$ : indicates a gain update error
- $HGC\_DONE\_INT$ : indicates gain updates have completed successfully

These bits are latching fields which, once set, remain set until a 1 is written to the respective bit; these bits can be polled at any time or in response to the interrupt being asserted.

## 4.8 Digital Filter Selection

The ADC input path incorporates a decimation filter and a high-pass filter. Four types of filter are supported:

- Fast roll-off, minimum phase
- Fast roll-off, linear phase
- Slow roll-off, minimum phase
- Slow roll-off, linear phase

The DAC output path incorporates an interpolation filter and a high-pass filter. Six types of filter are supported:

- Fast roll-off, minimum phase
- Fast roll-off, linear phase
- Slow roll-off, minimum phase
- Slow roll-off, linear phase
- Balanced roll-off, minimum phase
- Balanced roll-off, linear phase

The phase-responses are characterized as follows:

- The **minimum-phase** filters offer the lowest latency and an impulse response with no pre-ringing, at the expense of potential in-band phase distortion.
- The **linear-phase** filters have no phase distortion, but also higher latency and a symmetric impulse response.

The frequency-response options are characterized as follows:

- The **fast roll-off** filters maximize the audio signal bandwidth (as a function of the selected sample rate). The fast roll-off filters also provide deep stopband attenuation in the DAC output path. The signal bandwidth and stopband attenuation are prioritized over impulse response and group delay. The deep stopband attenuation minimizes out-of-band noise and aliased signal content.
- The **slow roll-off** filters are optimized for impulse response and group delay, with flat passband over the audible range to 20 kHz. The slow roll-off filters provide a more relaxed stopband specification in the DAC output path. The enhanced impulse response may improve perceived sound quality, especially for transient signal content.
- The **balanced roll-off** filters offer a superior impulse response and group delay as compared with the fast roll-off filters, while retaining a flat passband over the audible range to 20 kHz and deep stopband attenuation.

The ADC input path supports fast roll-off filter options for all sample rates and slow roll-off filter options for 44.1 kHz–384 kHz sample rates. The DAC output path supports filter options for different sample rates as indicated in [Table 4-13](#).

**Table 4-13. Digital Filter Options (DAC Output Path)**

Description	Sample Rate (kHz)									
	16	32	44.1	48	88.2	96	176.4	192	352.8	384
Fast roll-off, minimum phase	Yes	Yes	Yes	Yes	Yes	Yes	Yes	Yes	Yes	Yes
Fast roll-off, linear phase	Yes	Yes	Yes	Yes	Yes	Yes	Yes	Yes	Yes	Yes
Slow roll-off, minimum phase	—	—	Yes	Yes	Yes	Yes	Yes	Yes	—	—
Slow roll-off, linear phase	—	—	Yes	Yes	Yes	Yes	Yes	Yes	—	—
Balanced roll-off, minimum phase	—	—	—	—	Yes	Yes	Yes	Yes	Yes	Yes
Balanced roll-off, linear phase	—	—	—	—	Yes	Yes	Yes	Yes	Yes	Yes

In hardware control mode, the filter selection is determined by the CONFIG5 pin (see [Section 4.2](#)). The filter selection differs between the ADC input path and the DAC output path.

In software (I<sup>2</sup>C/SPI) control mode, the filters are configured separately for the ADC input and DAC output paths:

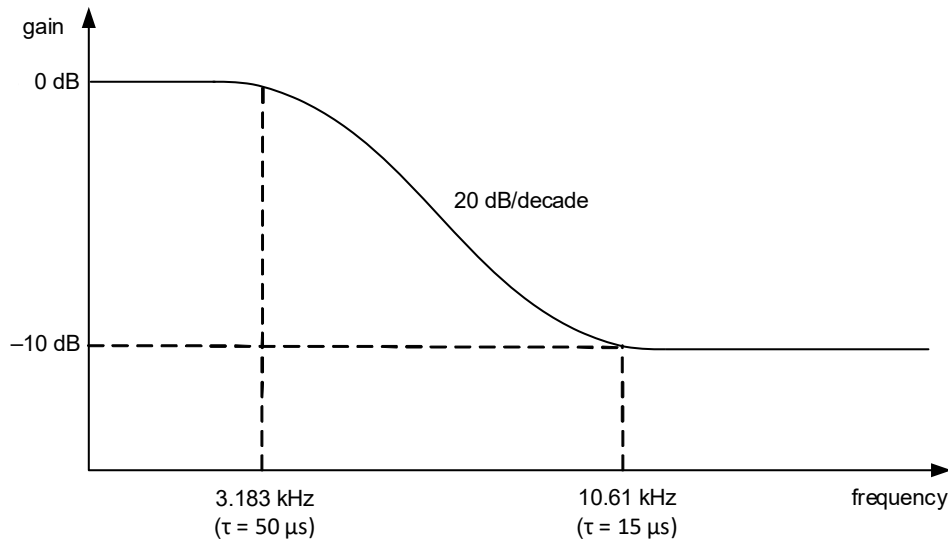
- The ADC decimation filter is selected using [IN\\_FILTER\\_SEL](#); the high-pass filter is enabled using [IN\\_HPF\\_EN](#).
- The DAC interpolation filter is selected using [OUT\\_FILTER\\_SEL](#); the high-pass filter is enabled using [OUT\\_HPF\\_EN](#).

A deemphasis filter can also be enabled in the DAC output path. The filter provides standard *Red Book* deemphasis, with corner frequencies corresponding to 15 μs/50 μs time constants, as illustrated in [Fig. 4-11](#).

The deemphasis filter is supported for 16 kHz, 32 kHz, 44.1 kHz, and 48 kHz sample rates. The filter is enabled using [OUT\\_DEEMPH\\_EN](#). If the sample rate is 44.1 kHz or 48 kHz, the applicable rate must be configured using [OUT\\_DEEMPH\\_FILT\\_SEL](#).

**Note:** The deemphasis filter is not supported for sample rates above 48 kHz; enabling the filter at sample rates higher than 48 kHz has no effect.

The de-emphasis filter response is illustrated in [Fig. 4-11](#).



**Figure 4-11. Deemphasis Filter Response**

**Note:** The interpolation and deemphasis filters are not supported on the DSD signal path (see [Section 4.10](#)).

## 4.9 Audio Serial Port (ASP)

The multichannel ASP supports the input/output of digital audio samples to/from the CS4233S. The ASP can be configured as a primary or secondary interface, and supports I<sup>2</sup>S, left-justified, and TDM data formats.

Timing specifications for the ASP are described in [Table 3-14](#). An option is supported to drive the output data (DOUT) on the rising or falling BCLK edge; driving on the rising edge (assuming noninverted BCLK polarity) can be used to support a larger load capacitance by increasing the time between the launching edge from the CS4233S and the sampling edge at the receiving device.

In hardware control mode, the ASP data format is determined by the CONFIG1 and CONFIG2 pins (see [Section 4.2](#)). In software (I<sup>2</sup>C/SPI) control mode, the ASP data format is configured using register fields.

In hardware mode, sample rates 16 kHz–192 kHz are supported (sample rates 16 kHz and 32 kHz are supported using autodetect in ASP Secondary Mode only). In software mode, sample rates 16 kHz–384 kHz are supported; sample rate 384 kHz is not supported by autodetect. The supported sample rates in ASP Primary Mode and ASP Secondary Mode are summarized in [Table 4-14](#).

**Table 4-14. Supported Sample Rates in ASP Primary Mode and ASP Secondary Mode**

Sample Rate (kHz)	ASP Primary Mode		ASP Secondary Mode	
	Hardware Control Mode	Software Control Mode	Hardware Control Mode	Software Control Mode
16–32	—	Configurable using <a href="#">SAMPLE_RATE</a>	Determined using autodetect only	Configurable using <a href="#">SAMPLE_RATE</a> (autodetect available)
44.1–192	Determined by CONFIG1 pin			Configurable using <a href="#">SAMPLE_RATE</a> (autodetect not available)
352.8, 384	—		—	Configurable using <a href="#">SAMPLE_RATE</a> (autodetect not available)

**Note:** The ASP interface is not supported if the DSD interface is enabled (see [Section 4.10](#)).

### 4.9.1 Primary and Secondary Operation

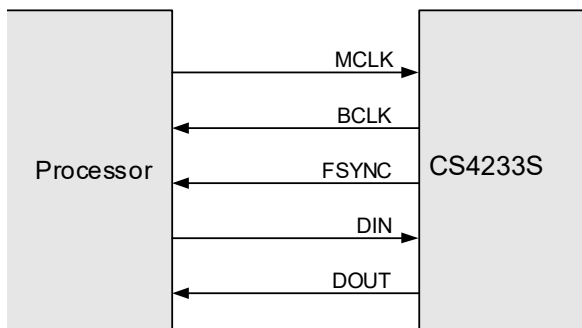
The ASP interface can operate as a primary or secondary interface. In the primary configuration, the BCLK and FSYNC signals are generated by the CS4233S. In the secondary configuration, the BCLK and FSYNC pins are inputs, allowing another device to drive the respective signals.

In ASP Secondary Mode, the external clocks (MCLK, BCLK, and FSYNC) must be derived from a common clock source. The clocks must be synchronized, but the phase difference is not important.

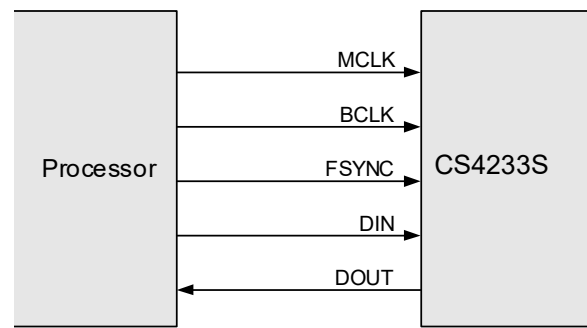
If clocking is provided by the crystal oscillator and the CS4233S is operating in ASP Secondary Mode, then the FSYNC and the BCLK signals should be derived from the common clock source provided by the CS4233S MCLK output.

In hardware control mode, the ASP is configured as a primary or secondary interface using the CONFIG1 pin (see [Section 4.2](#)). In software control mode, the ASP primary/secondary configuration is selected using `ASP_PRIMARY`.

The ASP operation as a primary or secondary interface with MCLK as the clocking source is illustrated in [Fig. 4-12](#) and [Fig. 4-13](#).

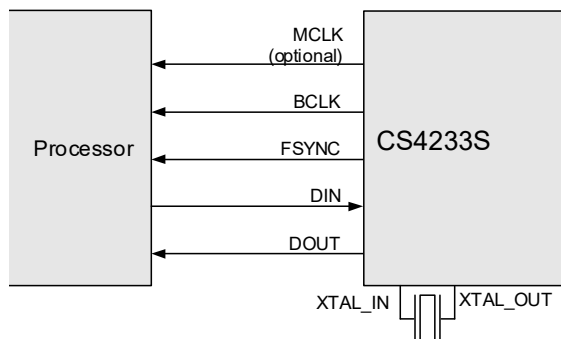


**Figure 4-12. Primary Mode, MCLK Clocking Source**

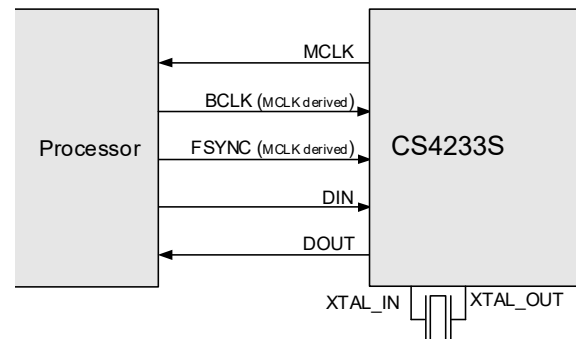


**Figure 4-13. Secondary Mode, MCLK Clocking Source**

The ASP operation as a primary or secondary interface with a crystal as the clocking source is illustrated in [Fig. 4-14](#) and [Fig. 4-15](#).



**Figure 4-14. Primary Mode, XTAL Clocking Source**



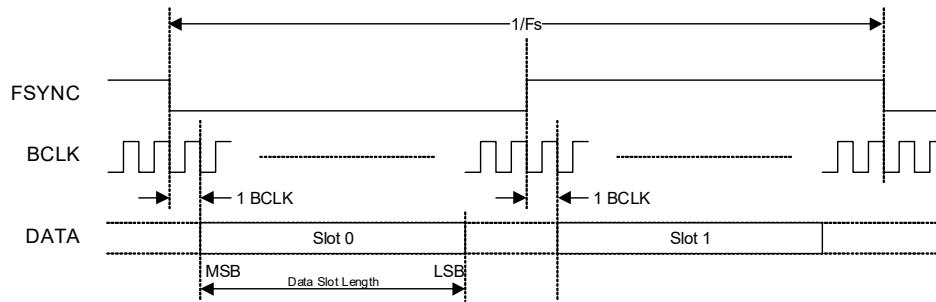
**Figure 4-15. Secondary Mode, XTAL Clocking Source**

## 4.9.2 ASP Data Formats

The ASP interface can be configured to operate in I<sup>2</sup>S, left-justified, or TDM data formats as illustrated in Fig. 4-16 through Fig. 4-18. The data-bit order is MSB first in each case; data words are encoded in 2's complement (signed, fixed-point) format. Each audio sample is allocated a time slot within the FSYNC frame.

- In I<sup>2</sup>S Mode, the MSB is valid on the second BCLK rising edge following an FSYNC transition. The other bits up to the LSB are valid on each successive BCLK cycle. Depending on word length, BCLK frequency, and sample rate, there may be unused BCLK cycles between the LSB of one sample and the MSB of the next.

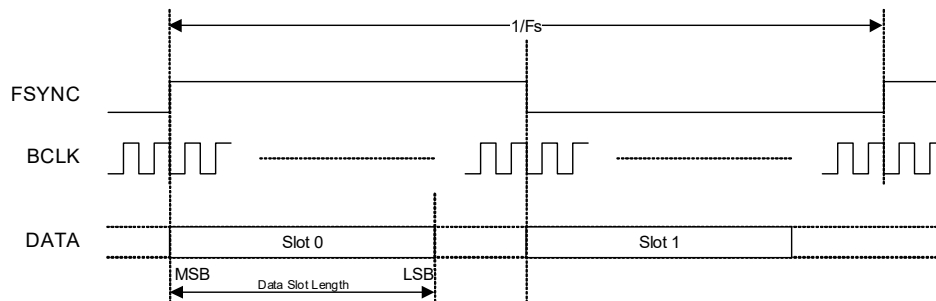
I<sup>2</sup>S Mode data format is shown in Fig. 4-16.



**Figure 4-16. I<sup>2</sup>S Data Format**

- In Left-Justified Mode, the MSB is valid on the first BCLK rising edge following an FSYNC transition. The other bits up to the LSB are valid on each successive BCLK cycle. Depending on word length, BCLK frequency, and sample rate, there may be unused BCLK cycles between the LSB of one sample and the MSB of the next.

Left-Justified Mode data format is shown in Fig. 4-17.



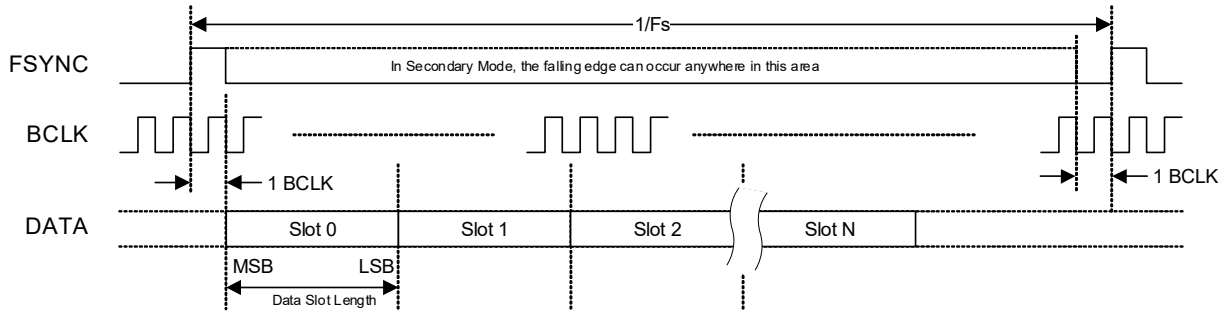
**Figure 4-17. Left-Justified Data Format**

- In TDM Mode, if the ASP is configured in Secondary Mode, the MSB of the first channel is valid on the second BCLK rising edge following a rising FSYNC edge. The other bits up to the LSB are valid on each successive BCLK cycle. If the ASP is configured in Primary Mode, the FSYNC signal can be configured as a pulse (default) or a square wave (with a 50% duty cycle). If the FSYNC signal is configured as a pulse, the MSB of the first channel is valid on the second BCLK rising edge following a rising FSYNC edge. The other bits up to the LSB are valid on each successive BCLK cycle.

In ASP Secondary Mode and in ASP Primary Mode with the FSYNC signal configured as a pulse, the subsequent channels follow immediately after the first channel. The pulse duration can be anything less than  $1/F_s$ , provided the falling edge of the frame pulse occurs at least one BCLK period before the rising edge of the next frame pulse.

Depending on word length, BCLK frequency, and sample rate, there may be unused BCLK cycles between the LSB of one sample and the MSB of the next.

TDM Mode data format in ASP Secondary Mode and ASP Primary Mode with FSYNC configured as a pulse is shown in Fig. 4-18.

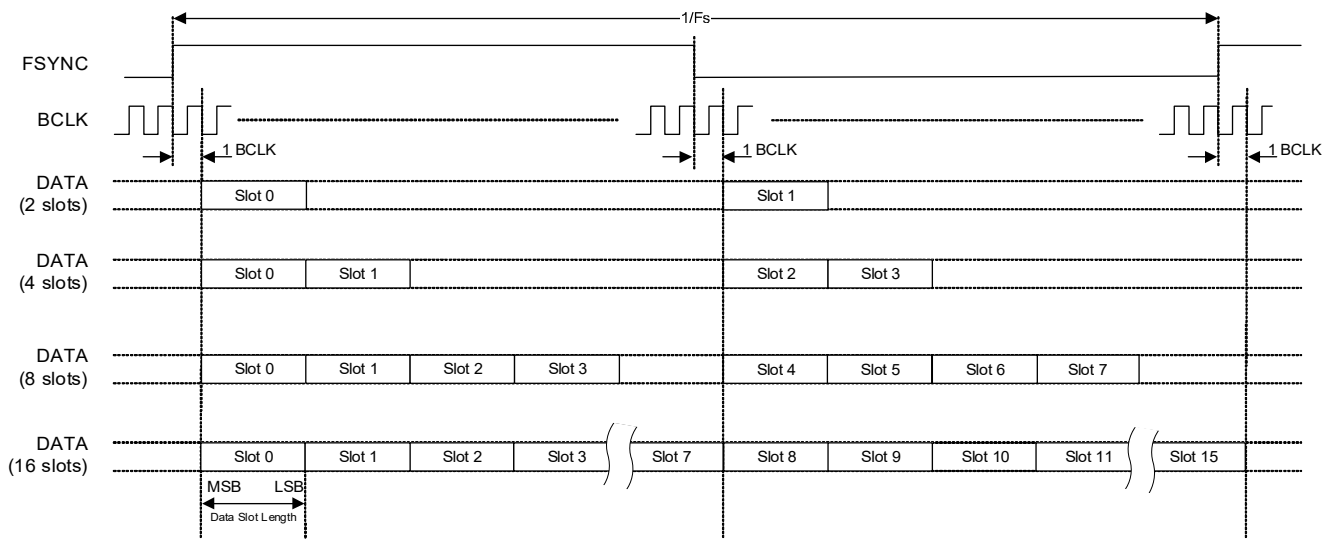


**Figure 4-18. TDM Data Format Primary Mode (FSYNC = Pulse) and Secondary Mode**

In ASP Primary Mode with the FSYNC signal configured as a square wave, the slots are aligned with both rising and falling edges of FSYNC and half of the available slots occur within each phase of the FSYNC cycle. The total number of available slots is determined by the sample rate, as described in Table 4-16.

- The MSB of the first channel in each phase of the FSYNC cycle is valid on the second BCLK rising edge following the rising and falling FSYNC edge respectively. The other bits up to the LSB are valid on each successive BCLK cycle. Depending on word length, BCLK frequency, sample rate, and number of available slots, there may be unused BCLK cycles between the LSB of one sample and the MSB of the next.

TDM Mode data format in ASP Primary Mode with FSYNC configured as a square wave is shown in Fig. 4-19.



**Figure 4-19. TDM Data Format Primary Mode (FSYNC = Square Wave)**

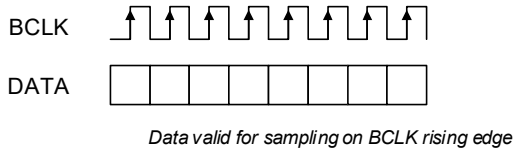
### 4.9.3 ASP Configuration

In hardware control mode, the ASP data format is determined by the CONFIG1 and CONFIG2 pins (see Section 4.2).

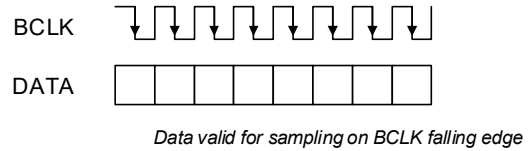
In software control mode, the ASP data format is configured using `SAMPLE_RATE`, and `ASP_FORMAT`. If ASP Primary Mode is selected (see Section 4.9.1), the BCLK frequency is configured using `ASP_BCLK_FREQ` and the FSYNC waveform type (pulse or square wave) is configured using `ASP_FSYNC_TYPE`.

In software control mode, the BCLK polarity is selected using `ASP_BCLK_INV`. The polarity selection is valid in Primary and Secondary Modes, and determines whether the data is valid for sampling on the rising edge or the falling edge.

The BCLK polarity is illustrated in Fig. 4-20 and Fig. 4-21. In hardware control mode, the BCLK polarity is assumed to be noninverted.



**Figure 4-20. Noninverted BCLK**



**Figure 4-21. Inverted BCLK**

In TDM Mode, the two data-format options are supported as follows:

- TDM Mode—minimum slots. The ASP data format is configured to support two slots. This mode allows the BCLK rate to be as low as possible, equating to a minimum of 128 BCLK cycles per audio sample at a minimum sample rate of 64 Fs.
- TDM Mode—maximum time slots. The ASP data format is configured to support the maximum number of time slots for the applicable BCLK rate. The mode is designed for the maximum BCLK rate (22.5792 MHz for 44.1 kHz-related sample rates, or 24.576 MHz for 48 kHz-related sample rates), enabling the maximum possible bandwidth on the ASP data bus to be shared with other devices.

If the ASP is configured for TDM Mode with maximum time slots, the output data (DOUT) can be driven either on the rising or falling BCLK edge. Driving on the rising edge (assuming noninverted BCLK polarity) can be used to support a larger load capacitance by increasing the time between the launching edge from the CS4233S and the sampling edge at the receiving device.

Note that the ASP timing options are dependent on the behavior of the receiving device. It is assumed, for noninverted BCLK, the data is sampled on the rising BCLK edge. Similarly, for inverted BCLK, it is assumed the data is sampled on the falling BCLK edge.

The DOUT drive options for half-cycle and full-cycle mode are described in Table 4-15. In full-cycle mode, the output data is driven on the same BCLK edge as it is sampled (i.e., one full BCLK cycle before the sampling edge). In half-cycle mode, the output data is driven on the opposite BCLK edge as it is sampled (i.e. one half BCLK cycle before the sampling edge), this is also illustrated in Table 3-14.

**Table 4-15. TDM Mode (Maximum Time Slots)—DOUT Drive Timing**

TDM Mode <sup>1</sup>	BCLK Polarity <sup>2</sup>	DOUT Launching (Drive) Edge	DOUT Latching (Sampling) Edge
Half-cycle	Noninverted	BCLK falling	BCLK rising
	Inverted	BCLK rising	BCLK falling
Full-cycle	Noninverted	BCLK rising	BCLK rising
	Inverted	BCLK falling	BCLK falling

1. The TDM variant is selected using the CONFIG2 pin (in hardware control mode) or `ASP_FORMAT` (in software control mode).
2. The BCLK polarity is selected using `ASP_BCLK_INV` in software control mode. In hardware control mode, the polarity is assumed noninverted.

The ASP configuration depends on the sample rate and the selected data format as described in [Table 4-16](#).

**Table 4-16. ASP Data Format**

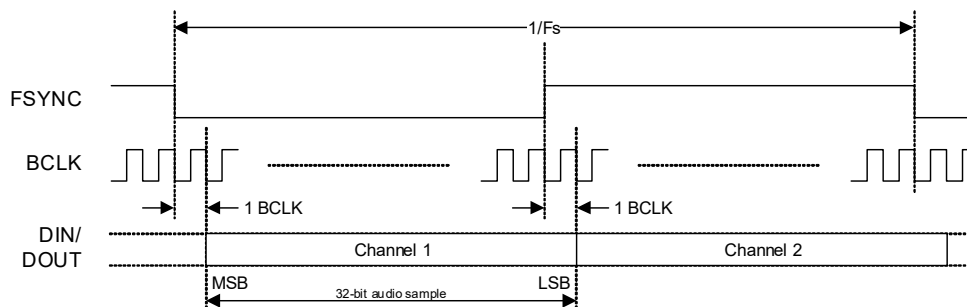
ASP Format <sup>1</sup>	ASP Sample Rate <sup>2,3</sup>	Time Slots per Frame <sup>4</sup>	BCLK Rate <sup>5,6</sup>
I <sup>2</sup> S, Left-Justified	16 kHz	2	BCLK ≥ 64×Fs <sup>[7]</sup>
	32 kHz		BCLK ≥ 64×Fs <sup>[8]</sup>
	44.1 kHz, 48 kHz		BCLK ≥ 64×Fs
	88.2 kHz, 96 kHz		BCLK ≥ 64×Fs
	176.4 kHz, 192 kHz		BCLK ≥ 64×Fs
	352.8 kHz, 384 kHz		BCLK ≥ 64×Fs
	Autodetect (16 kHz–192 kHz)		BCLK ≥ 64×Fs
TDM—minimum time slots	16 kHz	2	BCLK ≥ 64×Fs <sup>[7]</sup>
	32 kHz		BCLK ≥ 64×Fs <sup>[8]</sup>
	44.1 kHz, 48 kHz		BCLK ≥ 64×Fs
	88.2 kHz, 96 kHz		BCLK ≥ 64×Fs
	176.4 kHz, 192 kHz		BCLK ≥ 64×Fs
	352.8 kHz, 384 kHz		BCLK ≥ 64×Fs
	Autodetect (16 kHz–192 kHz)		BCLK ≥ 64×Fs
TDM—maximum time slots	16 kHz	16	BCLK ≥ 512×Fs <sup>[7]</sup>
	32 kHz		BCLK ≥ 512×Fs <sup>[8]</sup>
	44.1 kHz, 48 kHz		BCLK = 512×Fs
	88.2 kHz, 96 kHz	8	BCLK = 256×Fs
	176.4 kHz, 192 kHz	4	BCLK = 128×Fs
	352.8 kHz, 384 kHz	2	BCLK = 64×Fs
	Autodetect (16 kHz–192 kHz)	4	BCLK ≥ 128×Fs

1. The ASP format is selected using the CONFIG2 pin (in hardware control mode) or [ASP\\_FORMAT](#) (in software control mode).
2. The sample rate is selected using the CONFIG1 pin (in hardware control mode) or [SAMPLE\\_RATE](#) (in software control mode).
3. Sample rates 16 kHz–192 kHz are supported in hardware and software control modes; sample rate 384 kHz is supported in software control mode only.
4. Time slots per frame is the number of data-sample time slots supported on the DIN/DOUT pins.
5. The BCLK rate must be a constant integer multiple of the sample rate (Fs).
6. In ASP Primary Mode (hardware control), the BCLK frequency is the minimum specified rate. In ASP Primary Mode (software control), the BCLK frequency is configured using [ASP\\_BCLK\\_FREQ](#).
7. In ASP Primary Mode, the specified minimum BCLK frequency for 16 kHz sample rate is not supported. The available options correspond to 192×Fs, 384×Fs, 768×Fs, or 1536×Fs.
8. In ASP Primary Mode, the specified minimum BCLK frequency for 32 kHz sample rate is not supported. The available options correspond to 96×Fs, 192×Fs, 384×Fs, or 768×Fs.

The ASP data format in I<sup>2</sup>S, Left-Justified, and TDM interface modes as illustrated in [Fig. 4-22](#) through [Fig. 4-25](#). Refer to [Table 4-16](#) for the applicable definition.

- If I<sup>2</sup>S data format is selected, the ASP supports audio channels 1–2 as shown in [Fig. 4-22](#). The minimum BCLK rate is 64×Fs (where Fs is the sample rate). In ASP Primary Mode, the minimum BCLK rate of 64×Fs is not supported for sample rates of 16 kHz or 32 kHz. A higher BCLK frequency can be used, resulting in unused BCLK cycles between the LSB of one sample and the MSB of the next.

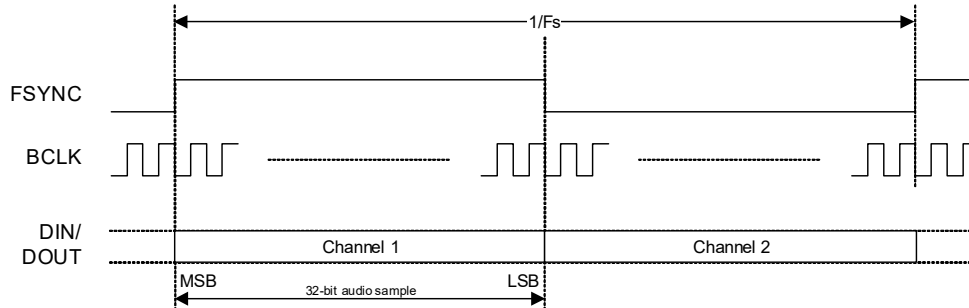
The input data is provided on ASP\_DIN; the output data is provided on ASP\_DOUT.



**Figure 4-22. I<sup>2</sup>S Data Format**

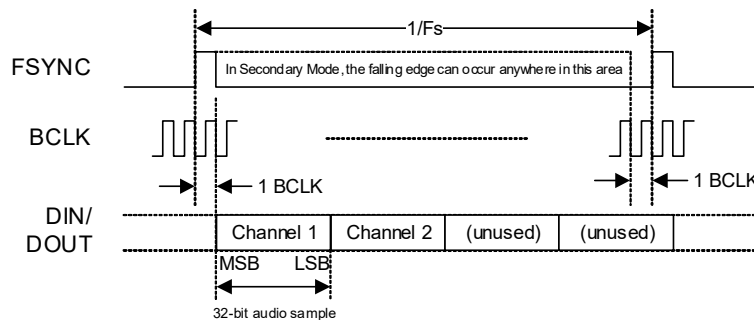
- If Left-Justified data format is selected, the ASP supports audio channels 1–2 as shown in Fig. 4-23. The minimum BCLK rate is  $64 \times F_s$  (where  $F_s$  is the sample rate). In ASP Primary Mode, the minimum BCLK rate of  $64 \times F_s$  is not supported for sample rates of 16 kHz or 32 kHz. A higher BCLK frequency can be used, resulting in unused BCLK cycles between the LSB of one sample and the MSB of the next.

The input data is provided on ASP\_DIN; the output data is provided on ASP\_DOUT.



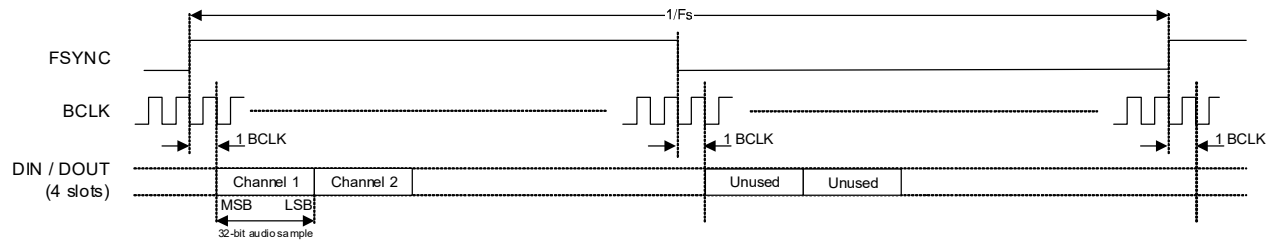
**Figure 4-23. Left-Justified Data Format**

- In TDM Mode, the FSYNC frame is configured for 2, 4, 8, or 16 slots as specified in Table 4-16. In 4-, 8-, and 16-slot modes, the slot assignment for audio channels 1–2 is selected using the CONFIG3 pin (in hardware control mode—see Section 4.2) or else using ASP\_TDM\_SLOT (in software control mode). In 2-slot modes, the default slot assignment (slots 0–1) should be selected. The BCLK rate is related to the sample rate ( $F_s$ ) as described in Table 4-16. Where applicable, the BCLK rate can be higher than the stated minimum, resulting in additional unused BCLK cycles between the last slot in the frame and the start of the next frame. The ASP\_DOUT pin is high impedance if the CS4233S is not transmitting data, allowing other devices on the bus to transmit data during any unused time slots. The input data is provided on ASP\_DIN; the output data is provided on ASP\_DOUT. An example of the 4-slot TDM format in ASP Secondary Mode and in ASP Primary Mode with the FSYNC signal configured as a pulse is shown in Fig. 4-24. In this example, audio channels 1–2 occupy TDM slots 0–1 respectively.



**Figure 4-24. TDM Data Format, 4-Slot Example (FSYNC = Pulse)**

An example of the 4-slot TDM format in ASP Primary Mode with the FSYNC signal configured as a square wave is shown in Fig. 4-25. In this example, audio channels 0 and 1 occupy TDM slots 0 and 1 in the high (Logic 1) phase of the FSYNC signal, TDM slot 0 and 1 in the low (Logic 0) phase of the FSYNC signal are unused.



**Figure 4-25. TDM Data Format, 4-Slot Example (FSYNC = Square Wave)**

## 4.10 DSD Interface

Direct Stream Digital (DSD) is a high-resolution audio-coding standard that employs 1-bit sampling at high oversample rates. The DSD interface uses noise shaping and other filters to decode the data for the purposes of analog audio playback. The CS4233S supports a two-channel DSD interface.

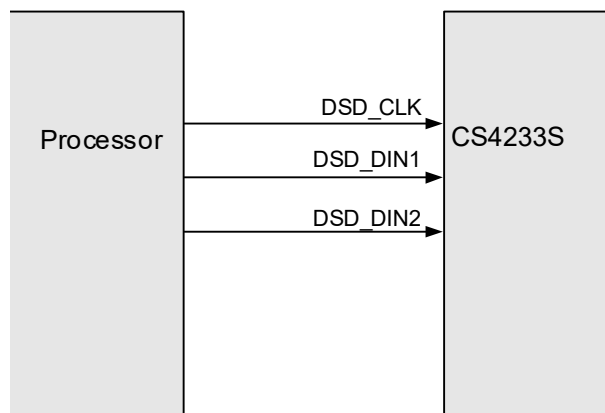
The DSD interface supports digital input at oversample rates up to  $256 \times F_s$ . Phase modulation of the digital input is also supported at  $64 \times F_s$  oversample rate. A selectable high-pass filter is provided in the DSD signal path.

Note the DSD interface is supported in software control mode only.

### 4.10.1 DSD Enable

The DSD interface is enabled using `DSD_EN`. The ASP interface (see Section 4.9) is disabled if the DSD interface is enabled.

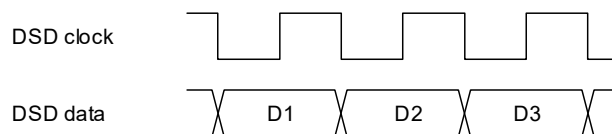
The DSD interface supports two-channel input using the respective `DSD_DINn` data pins. The timing of the DSD data is supported using the `DSD_CLK` clock input. The DSD interface connections are illustrated in Fig. 4-26.



**Figure 4-26. DSD Interface Connection**

### 4.10.2 DSD Format

The DSD interface format is shown in Fig. 4-27. In this default configuration, a new data bit is received on each falling CLK edge, for sampling at the next rising edge. See Table 3-15 for timing specifications.



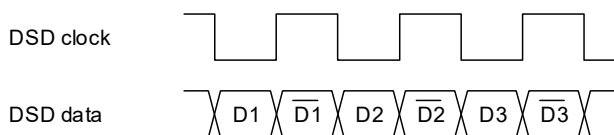
**Figure 4-27. DSD Interface Timing**

The oversample rate is configured using `DSD_OS`. This field must be configured to match the DSD input stream. Oversample rates  $64 \times F_s$ ,  $128 \times F_s$ , and  $256 \times F_s$  rates are supported (where  $F_s = 44.1$  kHz).

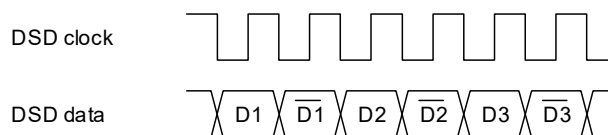
The CS4233S supports DSD phase modulation, where the DSD data is represented in *data plus data-inverted* format as shown in Fig. 4-28. Phase modulation is configured using `DSD_PM_EN`. Phase modulation is supported for  $64 \times F_s$  data rate only.

If phase modulation is enabled, the DSD clock rate is configured using `DSD_PM_SEL`. By default, the clock rate is  $128 \times F_s$  (i.e.,  $2 \times$  OSR rate). The clock rate can be adjusted to  $64 \times F_s$  if required.

The phase-modulation data formats are shown in Fig. 4-28 and Fig. 4-29.



**Figure 4-28. DSD Phase Modulation— $64 \times F_s$  CLK**



**Figure 4-29. DSD Phase Modulation— $128 \times F_s$  CLK**

### 4.10.3 Signal Level Control

The scaling of the DSD signal level, relative to the full-scale level of the CS4233S DAC output path, is configurable using `DSD_ZEROdB`. The scaling is defined with reference to the SACD standard for DSD signal levels.

### 4.10.4 High-Pass Filter

A high-pass filter is incorporated in the DSD signal path. The filter is enabled using `DSD_HPF_EN`. The filter is enabled by default.

**Note:** The digital filters described in Section 4.8 are not supported on the DSD path.

## 4.11 I<sup>2</sup>C/SPI Control Port

The CS4233S incorporates a control port, supporting I<sup>2</sup>C or SPI modes of operation; this is selected using `CONFIG1`, as described in Table 4-1. If the SPI control interface is required, it is recommended to use a pull-up resistor of 100 k $\Omega$ . In software control mode, the CS4233S is configured by writing to control registers using the control port.

The control port is automatically configured in I<sup>2</sup>C mode or SPI mode following the first valid I<sup>2</sup>C/SPI activity detected after power-on or hardware reset.

### 4.11.1 I<sup>2</sup>C Control Port

The I<sup>2</sup>C control port is supported using the following pins, which must be configured for the I<sup>2</sup>C function if required:

- `CONFIG2/SPI_SDI/I2C_SDA`
- `CONFIG3/SPI_SDO/I2C_SCL`

The CS4233S is a target device on the I<sup>2</sup>C bus—SCL is a clock input, while SDA is a bidirectional data pin. To allow arbitration of multiple targets (and/or multiple controllers) on the same interface, the CS4233S transmits Logic 1 by tristating the SDA pin, rather than pulling it high. An external pull-up resistor is required to pull the SDA line high so that the Logic 1 can be recognized by the controller.

In order to allow many devices to share a single two-wire control bus, every device on the bus has a unique 8-bit device address (this is not the same as the address of each register in the CS4233S). The LSB of the device address is the read/write bit; this bit is set to Logic 1 for read and Logic 0 for write.

The I<sup>2</sup>C device address is configured using the CONFIG1 pin as described in [Table 4-17](#).

**Table 4-17. I<sup>2</sup>C Address Selection—CONFIG1 pin**

Pin Configuration		I <sup>2</sup> C Address
Pull-up to VDD_IO1	0 kΩ	0x46 (write), 0x47 (read)
	4.7 kΩ	0x44 (write), 0x45 (read)
	22 kΩ	0x42 (write), 0x43 (read)
	100 kΩ	0x40 (write), 0x41 (read)

The host device indicates the start of data transfer with a high-to-low transition on SDA while SCL remains high. This indicates that a device address and subsequent address/data bytes follow. The CS4233S responds to the start condition and shifts in the next 8 bits on SDA (8-bit device address, including read/write bit, MSB first). If the device address received matches the device address of the CS4233S, the CS4233S responds by pulling SDA low on the next clock pulse (ACK). If the device address is not recognized or the R/W bit is set incorrectly, the CS4233S returns to the idle condition and waits for a new start condition.

If the device address matches the device address of the CS4233S, the data transfer continues. The controller indicates the end of data transfer with a low-to-high transition on SDA while SCL remains high. After receiving a complete address and data sequence the CS4233S returns to the idle state and waits for another start condition. If a start or stop condition is detected out of sequence at any point during data transfer (i.e., SDA changes while SCL is high), the device returns to the idle condition.

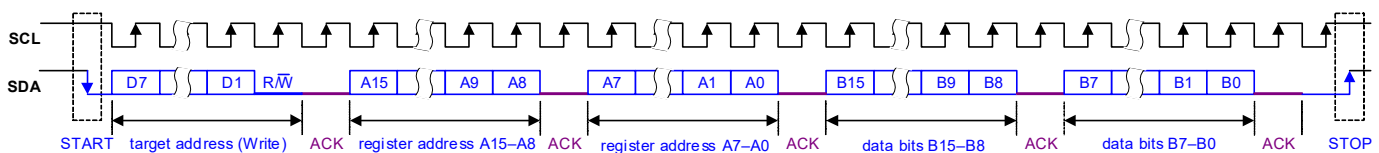
The I<sup>2</sup>C interface uses a 16-bit register address and 16-bit data words. The register address must be aligned to a 16-bit word boundary (i.e., the LSB must be 0). The full I<sup>2</sup>C message protocol also includes a device address, a read/write bit, and other signaling bits (see [Fig. 4-30](#) and [Fig. 4-31](#)).

The CS4233S supports the following read and write operations:

- Single write
- Single read
- Multiple write
- Multiple read

Continuous (multiple) read and write modes allow register operations to be scheduled faster than is possible with single register operations. In these modes, the CS4233S automatically increments the register address after each data word. Successive data words can be input/output every two data bytes.

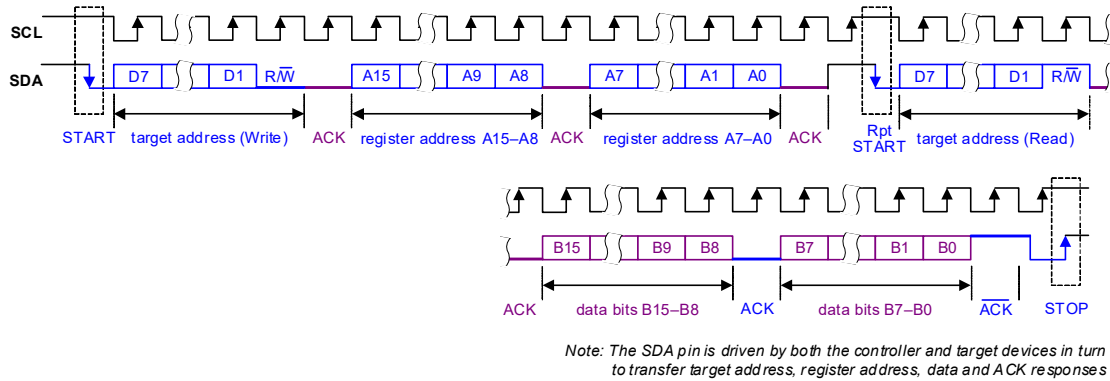
The I<sup>2</sup>C protocol for a single, 16-bit register write operation is shown in [Fig. 4-30](#).



*Note: The SDA pin is used as input for the control register address and data; SDA is pulled low by the receiving device to provide the acknowledge (ACK) response*

**Figure 4-30. Control Interface I<sup>2</sup>C Register Write**

The I<sup>2</sup>C protocol for a single, 16-bit register read operation is shown in Fig. 4-31.



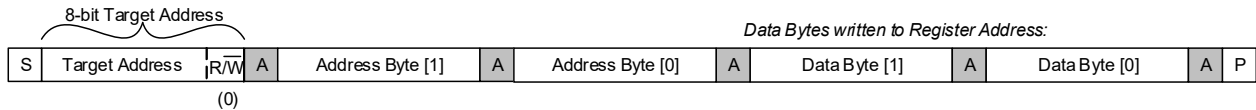
**Figure 4-31. Control Interface I<sup>2</sup>C Register Read**

The control interface also supports other register operations; the interface protocol for these operations is shown in Fig. 4-32 through Fig. 4-35. The terminology used in the following figures is detailed in Table 4-18.

**Table 4-18. Control Interface (I<sup>2</sup>C) Terminology**

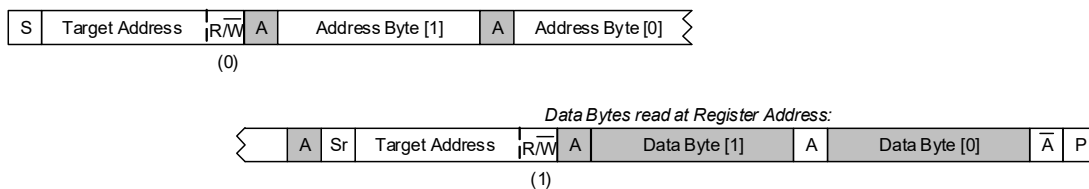
Terminology	Description
S	Start condition
Sr	Repeated start
A	Acknowledge (SDA low)
$\bar{A}$	No Acknowledge (SDA high)
P	Stop condition
R/ $\bar{W}$	Read/not Write: 0 = Write, 1 = Read
[White field]	Data flow from bus controller to CS4233S
[Gray field]	Data from CS4233S to bus controller

Fig. 4-32 shows a single register write to a specified address.



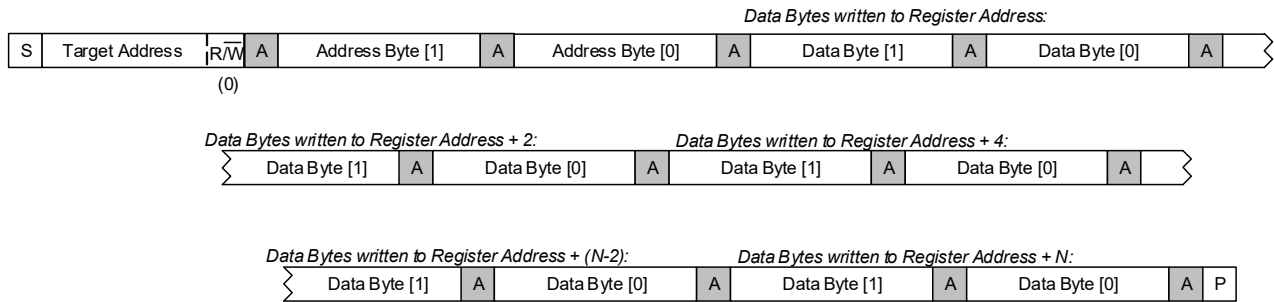
**Figure 4-32. Single-Register Write to Specified Address**

Fig. 4-33 shows a single register read from a specified address.



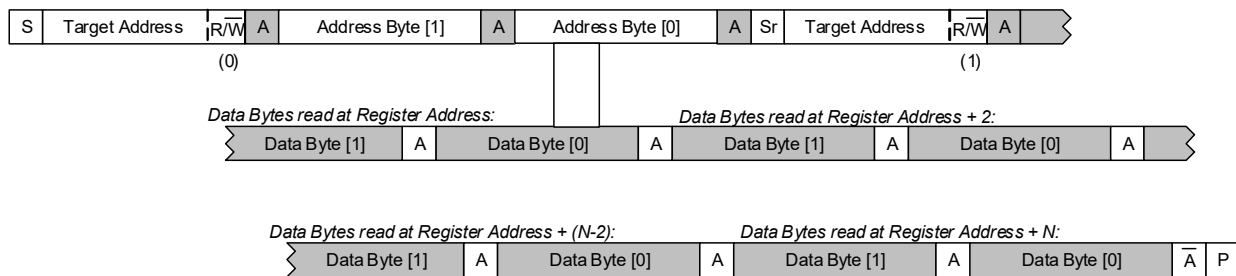
**Figure 4-33. Single-Register Read from Specified Address**

Fig. 4-34 shows a multiple register write to a specified address.



**Figure 4-34. Multiple-Register Write to Specified Address**

Fig. 4-35 shows a multiple register read from a specified address.



**Figure 4-35. Multiple-Register Read from Specified Address**

## 4.11.2 SPI Interface

The SPI interface is supported using the following pins, which must be configured for the SPI function if required:

- CONFIG1/SPI\_CS
- CONFIG2/SPI\_SDI/I2C\_SDA
- CONFIG3/SPI\_SDO/I2C\_SCL
- CONFIG5/SPI\_SCK

To ensure that the control port is inactive prior to use,  $\overline{\text{SPI\_CS}}$  must be deasserted (i.e., Logic 1) during device startup;  $\overline{\text{RESET}}$  must remain asserted (i.e., Logic\_0) until  $\overline{\text{SPI\_CS}}$  is deasserted (i.e., Logic\_1), timing information is provided in [Table 3-13](#).

The SDI (data-input) pin supports the following behavior:

- In write operations ( $\overline{\text{R/W}} = 0$ ), the SDI pin input is driven by the controlling device.
- In read operations ( $\overline{\text{R/W}} = 1$ ), the SDI pin is ignored following receipt of the valid register address.

The SDO (data-output) pin supports the following behavior:

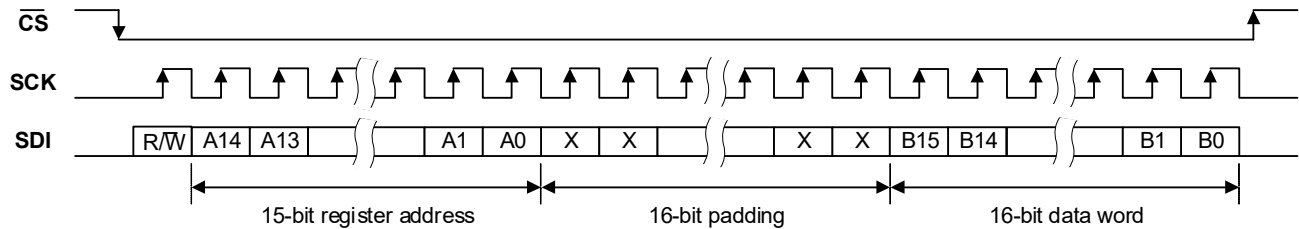
- If  $\overline{\text{CS}}$  is asserted (Logic 0), the SDO output is actively driven when outputting data and is high impedance at other times. If  $\overline{\text{CS}}$  is not asserted, the SDO output is high impedance.
- The high-impedance state of the SDO output allows the pin to be shared with other peripheral devices.
- The output (SDO) data bit is available to the host device at the rising edge of SCK. See [Table 3-17](#) for timing information.

The SPI interface uses a 15-bit register address and 16-bit data words. The full SPI message protocol also includes a read/write bit and a 16-bit padding phase (see [Fig. 4-36](#) and [Fig. 4-37](#)).

Continuous read and write modes enable multiple register operations to be scheduled faster than is possible with single register operations. In these modes, the CS4233S automatically increments the register address at the end of each data word, for as long as  $\overline{CS}$  is held low and SCK is toggled. Successive data words can be input/output every 16 clock cycles.

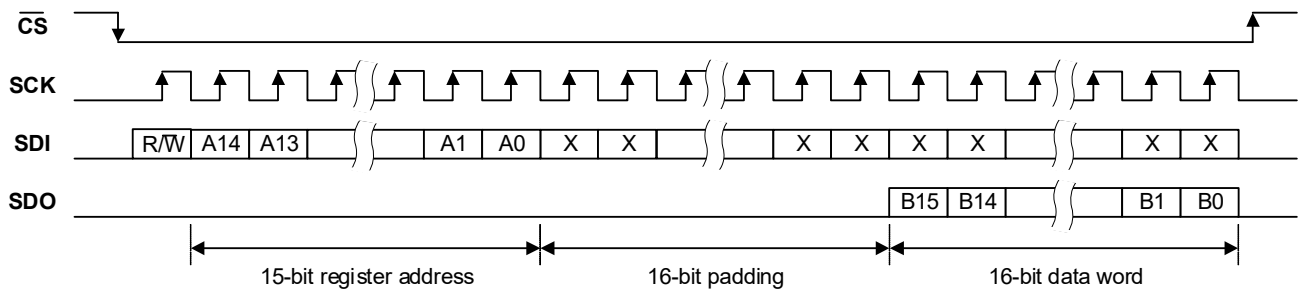
The SPI protocol is shown in Fig. 4-36 and Fig. 4-37.

Fig. 4-36 shows a single register write to a specified address.



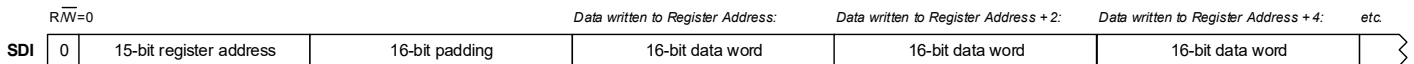
**Figure 4-36. Control Interface SPI Register Write**

Fig. 4-37 shows a single register read from a specified address.



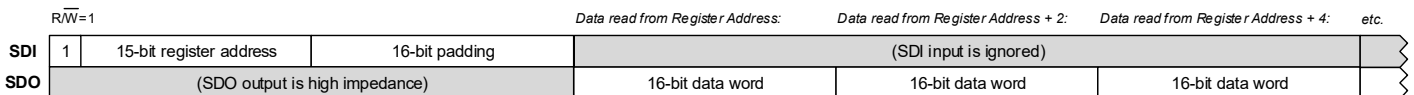
**Figure 4-37. Control Interface SPI Register Read**

Fig. 4-38 shows a multiple register write to a specified address.



**Figure 4-38. Multiple-Register Write to Specified Address**

Fig. 4-39 shows a multiple register read from a specified address.



**Figure 4-39. Multiple-Register Read from Specified Address**

## 4.12 Interrupts

The CS4233S incorporates an interrupt controller for monitoring event conditions. Inputs to the interrupt controller include signal activity detection, clip warning, virtual PAD, and HGC warning/error conditions.

Any of these input conditions can be used to assert the IRQ output signal. The IRQ signal can be configured as an output on different pins as described in [Table 4-19](#).

**Table 4-19. IRQ Event Logic Output Pins**

Pin Name	Power Supply	Control Field	Notes
GPIO1 <sup>1</sup>	VDD_IO2	<a href="#">GPIO1_IRQ_EN</a>	IRQ not supported if GPIO1 is configured for virtual PAD or HGC external gain control.
HGC_CS/GPIO2 <sup>1</sup>	VDD_IO2	<a href="#">GPIO2_IRQ_EN</a>	
CONFIG4/CH_IDLE	VDD_IO1	<a href="#">CONFIG4_IRQ_EN</a>	IRQ not supported if pin is configured for signal activity detection.
CONFIG5/SPI_SCK	VDD_IO1	<a href="#">SPI_SCK_IRQ_EN</a>	IRQ not supported if SPI control interface is used.

1. The GPIO logic levels are referenced to the VDD\_IO2 domain; level shifting may be required if connecting to a host interface operating at a different level (see [Table 3-11](#) for details).

An interrupt register bit, [x\\_INT](#), is associated with each interrupt input, indicating that the respective event has been detected. The interrupt bits are latching fields which, once set, remain set until a 1 is written to the respective bits. The interrupt register bits can be polled at any time or in response to the IRQ output signal being asserted.

A status bit, [x\\_STS](#), is provided to indicate the current status of the signal activity detection, clip warning, and virtual PAD inputs.

Mask bits, [x\\_MASK](#), are provided for each input condition, to enable or disable the respective functions from contributing to the interrupt logic output. The interrupt register bits ([x\\_INT](#)) remain valid—even if masked—but the masked interrupts do not cause the interrupt logic output to be asserted.

The output can be either CMOS driven or open drain; this is selected using [IRQ\\_OP\\_CFG](#).

- If the output is configured as CMOS driven, the IRQ output signal is active high, i.e., Logic 1 if one or more unmasked interrupt is asserted.
- If the output is configured as open drain, the IRQ output signal is active low, i.e., Logic 0 if one or more unmasked interrupt is asserted.

The IRQ signal represents the logical OR of the unmasked interrupt registers. The IRQ output remains asserted until all of the associated interrupts have been either masked or reset.

The IRQ status is indicated using [IRQ\\_STS](#); this bit is set if one or more unmasked interrupt is asserted.

## 4.13 Device ID

The device ID, and other associated data, can be read from the control fields listed in [Table 4-20](#).

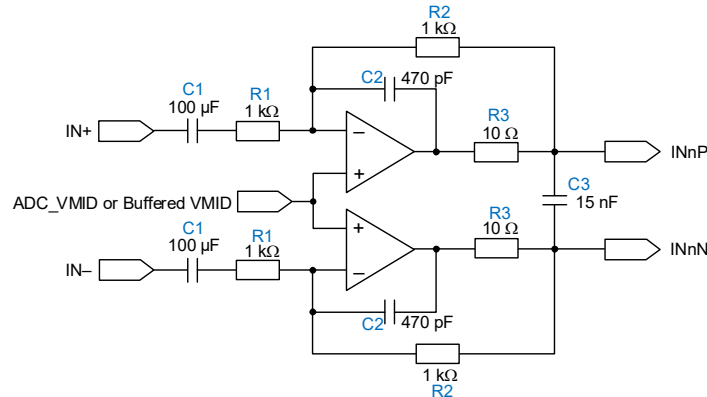
**Table 4-20. Device ID**

Label	Description
<a href="#">DEVID_0</a>	Lower bytes of the Device ID
<a href="#">DEVID_1</a>	Upper bytes of the Device ID
<a href="#">AREVID</a>	All-layer device revision
<a href="#">MTLREVID</a>	Metal-layer device revision

## 5 Applications

### 5.1 Input Buffer Circuit

The analog input channels are supported using external buffer circuits. A typical buffer circuit comprising a high-pass filter and anti-alias filter is shown in Fig. 5-1. The typical buffer circuit shown produces a full-scale (0 dBFS) output from a  $2 V_{\text{RMS}}$  differential input.



**Figure 5-1. Differential Input Buffer Circuit**

The high-pass filter is provided by the AC-coupling capacitor,  $C_1$  and series resistor,  $R_1$ . Using the values shown, the -3 dB cut-off frequency ( $F_C$ ) can be calculated using the following equation:

$$F_C = \frac{1}{2\pi R_1 C_1} = \frac{1}{2\pi \times 1000 \times (100 \times 10^{-6})} = 1.59 \text{ Hz}$$

The anti-alias filter is provided by the operational amplifier and associated feedback components. The objective is to provide a flat passband for the audio input bandwidth, and sufficient attenuation at the ADC-modulator sample frequency. The low output impedance of the circuit minimizes the distortion of the signal path.

The typical filter shown provides an approximated -3 dB cut-off frequency of 424 kHz, suitable for the highest CS4233S sample rate of 384 kHz. The attenuation slope of -12 dB/octave results in 42 dB attenuation at the ADC-modulator sample frequency of 6.144 MHz.

The -3 dB cut-off frequency is approximated by the following equation:

$$F_C = \frac{1}{2\pi \sqrt{R_2 R_3 C_2 C_3}} = \frac{1}{2\pi \sqrt{1000 \times 10 \times 470 \times 10^{-12} \times 2 \times 15 \times 10^{-9}}} = 424 \text{ kHz}$$

The gain of the input buffer is set by  $R_1$  and  $R_2$ . The gain should be configured to provide a full-scale signal of  $2 V_{\text{RMS}}$  at the input to the CS4233S. The values shown in Fig. 5-1 provide a ratio of 1; in this configuration, the buffer supports a full-scale input of  $2 V_{\text{RMS}}$ .

The ADC\_VMID reference is provided as an output from the CS4233S. The ADC\_VMID current (arising from capacitor leakage and the input-buffer circuit) must be less than the maximum output current specified in Table 3-12. If a larger current is required, an external VMID buffer should be used; an example of a buffered VMID circuit is provided in Table 3-12.

### 5.1.1 Unused Input Pins

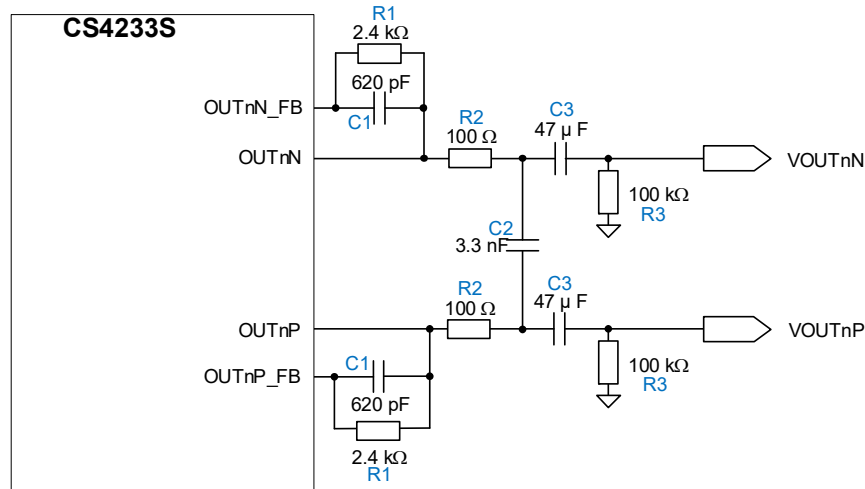
The recommended input buffer circuit (see Fig. 5-1) provides a differential connection to the input pins INnP and INnN. Alternative input-buffer circuits may use only a single-ended connection to INnP or INnN. If a single-ended input configuration is used, the unused input pin must be connected to a buffered VMID reference, see Table 3-12 for a buffered VMID circuit. If one, or more, input channel is not used (disabled), the respective unused input pin INnP or INnN should be floating (no connection).

## 5.2 Output Buffer Circuit

The CS4233S incorporates a high-performance sigma-delta current-mode DAC with integrated operational amplifiers for current-to-voltage conversion. External components for the current-to-voltage conversion and out-of-band filtering can be selected for flexible integration and to optimize dynamic range.

### 5.2.1 Typical Output Circuit

A typical output connection circuit is shown in Fig. 5-2. The circuit produces a 2 V<sub>RMS</sub> differential output from a full-scale (0 dBFS) digital input.



**Figure 5-2. Typical Output Connection Circuit**

The feedback resistor, R<sub>1</sub> determines the full-scale differential output voltage; a maximum output voltage of 2 V<sub>RMS</sub> is supported at the OUTnN and OUTnP pins. R<sub>1</sub> is calculated as follows:

$$R_1 = \frac{\text{Full-scale Output Voltage (V}_{\text{RMS}})}{0.835 \text{ mA}_{\text{RMS}}} = \frac{2}{0.835 \times 10^{-3}} = 2.4 \text{ k}\Omega$$

The filter is provided by the integrated operational amplifiers and associated feedback components C<sub>1</sub> and R<sub>1</sub>. The objective is to provide a flat passband for the audio output bandwidth. The cut-off frequency of the filter is calculated as follows:

$$F_C = \frac{1}{2\pi R_1 C_1} = \frac{1}{2\pi \times 2400 \times 620 \times 10^{-12}} = 107 \text{ kHz}$$

R<sub>2</sub> and C<sub>2</sub> create an output filter to reduce out-of-band noise of the output. The cut-off frequency of the filter is calculated as follows:

$$F_C = \frac{1}{2\pi R_2 C_2} = \frac{1}{2\pi \times 100 \times (2 \times 3.3 \times 10^{-9})} = 241 \text{ kHz}$$

$R_3$  and  $C_3$  form a high-pass filter, which removes the DC bias of the voltage output. The cut-off frequency of the filter is calculated as follows:

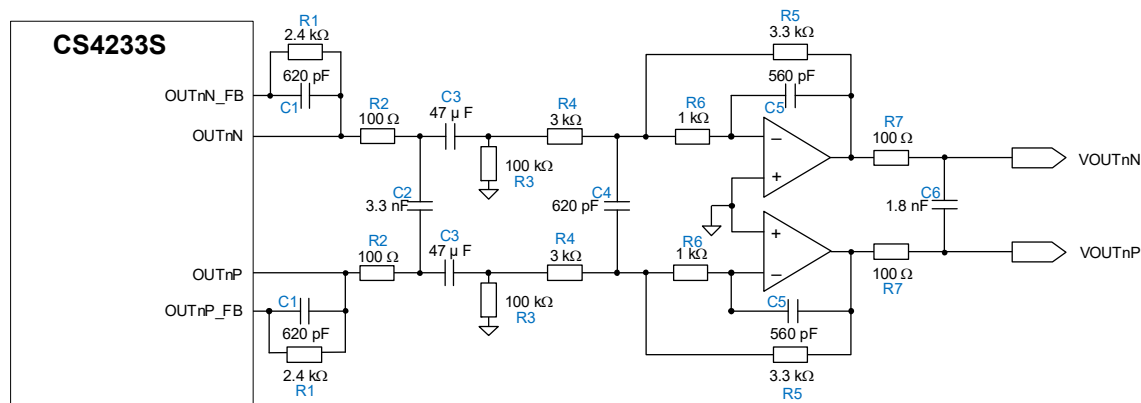
$$F_C = \frac{1}{2\pi R_3 C_3} = \frac{1}{2\pi \times 100 \times 10^3 \times 47 \times 10^{-6}} = 0.033 \text{ Hz}$$

## 5.2.2 Alternative Output Circuits

The typical circuit shown in Fig. 5-2 is recommended for optimal performance. Example line driver circuits are described in Section 5.2.2.1 and Section 5.2.2.2; specifications detailed in Section 3 are not applicable.

### 5.2.2.1 Example Active Differential Line Driver Circuit

An example of an active differential line-driver circuit is shown in Fig. 5-3, the output connection circuit shown produces a 2.2  $V_{RMS}$  differential output from a full-scale (0 dBFS) digital input.



**Figure 5-3. Example Active Differential Line Driver Circuit**

The feedback resistor,  $R_1$  determines the full-scale differential output voltage; a maximum output voltage of 2  $V_{RMS}$  is supported at the OUTnN and OUTnP pins.  $R_1$  is calculated as follows

$$R_1 = \frac{\text{Full-scale Output Voltage (} V_{RMS} \text{)}}{0.835 \text{ mA}_{RMS}} = \frac{2}{0.835 \times 10^{-3}} = 2.4 \text{ k}\Omega$$

The filter is provided by the integrated operational amplifiers and associated feedback components  $C_1$  and  $R_1$ . The objective is to provide a flat passband for the audio output bandwidth. The cut-off frequency of the filter is calculated as follows:

$$F_C = \frac{1}{2\pi R_1 C_1} = \frac{1}{2\pi \times 2400 \times 620 \times 10^{-12}} = 107 \text{ kHz}$$

$R_2$  and  $C_2$  create an output filter to reduce the out-of-band noise of the output. The cut-off frequency of the filter is calculated as follows:

$$F_C = \frac{1}{2\pi R_2 C_2} = \frac{1}{2\pi \times 100 \times (2 \times 3.3 \times 10^{-9})} = 241 \text{ kHz}$$

$C_3$  removes the DC bias of the CS4233S output and forms a high-pass filter with parallel resistance of  $R_3$  and  $R_4$ . The cut-off frequency of the filter is calculated as follows:

$$F_C = \frac{1}{2\pi \left( \frac{R_3 \times R_4}{R_3 + R_4} \right) C_3} = \frac{1}{2\pi \times \left( \frac{100 \times 10^3 \times 3 \times 10^3}{100 \times 10^3 + 3 \times 10^3} \right) \times 47 \times 10^{-6}} = 1.16 \text{ Hz}$$

R4 and C4 create a low-pass filter. The cut-off frequency of the filter is calculated as follows:

$$F_C = \frac{1}{2\pi R_4 2C_4} = \frac{1}{2\pi \times 3 \times 10^3 \times (2 \times 620 \times 10^{-9})} = 42.8 \text{ kHz}$$

R5, R6, and C5 create a low-pass filter within the operational amplifier feedback loop. The cut-off frequency of the filter is calculated as follows:

$$F_C = \frac{1}{2\pi(R_5 + R_6)C_5} = \frac{1}{2\pi \times (3.3 \times 10^3 + 1 \times 10^3) \times 560 \times 10^{-9}} = 66.1 \text{ kHz}$$

The gain of the output buffer is set by R4 and R5:

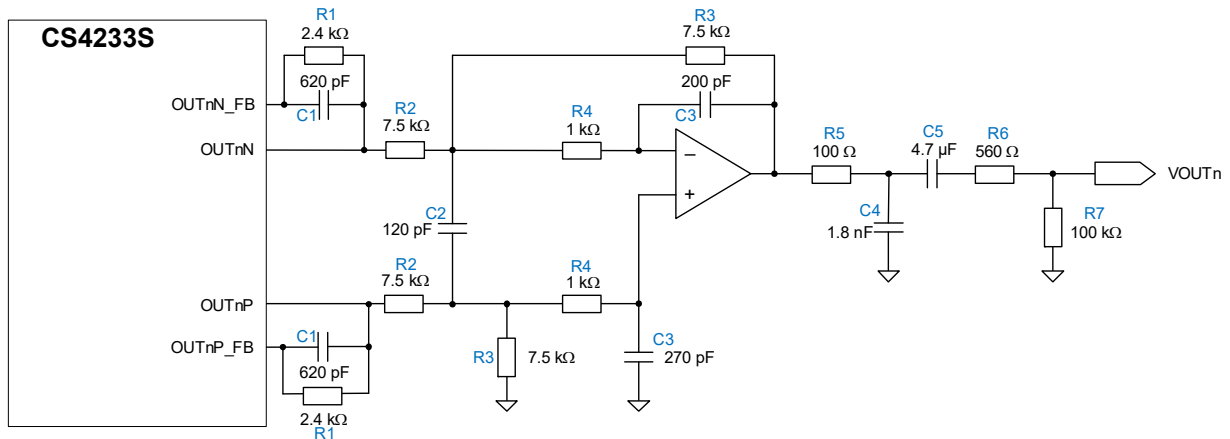
$$\text{Gain} = \frac{R_5}{R_4} = \frac{3 \times 10^3}{3.3 \times 10^3} = 1.1$$

R7 and C6 limit the output current; this ensures stability of the output and filters any out-of-band noise introduced by the operational amplifiers. The cut-off frequency of the filter is calculated as follows:

$$F_C = \frac{1}{2\pi R_7 2C_6} = \frac{1}{2\pi \times 100 \times (2 \times 1.8 \times 10^{-9})} = 442.1 \text{ kHz}$$

### 5.2.2.2 Example Active Differential-to-Single-Ended Line Driver Circuit

An example of an active differential-to-single-ended output circuit is shown in [Fig. 5-4](#). The circuit produces a 2.2 V<sub>RMS</sub> single-ended output from a full-scale (0 dBFS) digital input.



**Figure 5-4. Example Differential-to-Single-Ended Output Circuit**

The feedback resistor, R1 determines the full-scale differential output voltage; a maximum output voltage of 2 V<sub>RMS</sub> is supported at the OUTnN and OUTnP pins. R1 is calculated as follows:

$$R_1 = \frac{\text{Full-scale Output Voltage (V}_{RMS})}{0.835 \text{ mA}_{RMS}} = \frac{2}{0.835 \times 10^{-3}} = 2.4 \text{ k}\Omega$$

The filter is provided by the integrated operational amplifiers and associated feedback components C1 and R1. The objective is to provide a flat passband for the audio output bandwidth. The cut-off frequency of the filter is calculated as follows:

$$F_C = \frac{1}{2\pi R_1 C_1} = \frac{1}{2\pi \times 2400 \times 620 \times 10^{-12}} = 107 \text{ kHz}$$

R2 and C2 create an output filter to reduce the out-of-band noise of the output. The cut-off frequency of the filter is calculated as follows:

$$F_C = \frac{1}{2\pi R_2 C_2} = \frac{1}{2\pi \times (7.5 \times 10^3) \times (2 \times 120 \times 10^{-12})} = 88.4 \text{ kHz}$$

R3, R4, and C3 create a low-pass filter. The cut-off frequency of the filter is calculated as follows:

$$F_C = \frac{1}{2\pi(R_3 + R_4)C_3} = \frac{1}{2\pi \times (7.5 \times 10^3 + 1 \times 10^3) \times 200 \times 10^{-9}} = 93.6 \text{ kHz}$$

The gain of the output buffer is set by R2 and R3:

$$\text{Gain} = \frac{R_3}{R_2} = \frac{7.5 \times 10^3}{7.5 \times 10^3} = 1$$

R5, R6, R7, C4, and C5 remove the DC bias of the CS4233S output, limit the output current, ensure stability of the output, and filter any out-of-band noise introduced by the operation amplifiers.

The cut-off frequency of the high-pass filter is calculated as follows:

$$F_C = \frac{1}{2\pi(R_6 + R_7)C_5} = \frac{1}{2\pi \times (560 + 100 \times 10^3) \times (47 \times 10^{-6})} = 0.03 \text{ Hz}$$

The cut-off frequency of the low-pass filter is calculated as follows:

$$F_C = \frac{1}{2\pi R_5 C_4} = \frac{1}{2\pi \times 100 \times (1.8 \times 10^{-9})} = 884.2 \text{ kHz}$$

### 5.2.3 Unused Output Pins

The typical output connection circuit (Fig. 5-2) provides a biased differential output. Alternative output buffer circuits may only provide a single-ended output configuration. In this case, or where an output channel is not used, any unused output pin (OUTnX) must be connected to its respective OUTnX\_FB pin, as illustrated in Fig. 5-5.

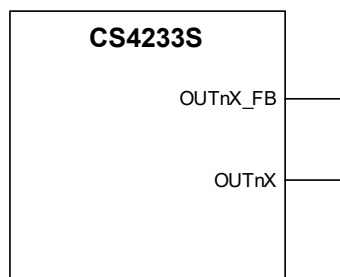


Figure 5-5. Unused Output Pin Connection

### 5.2.4 Recommended Components

To achieve the specified performance characteristics, the choice of external components should observe the following recommendations:

- Capacitors should be stable dielectric types, such as C0G (NP0) or electrolytic.
- Resistors should be low value where possible, to minimize thermal noise.

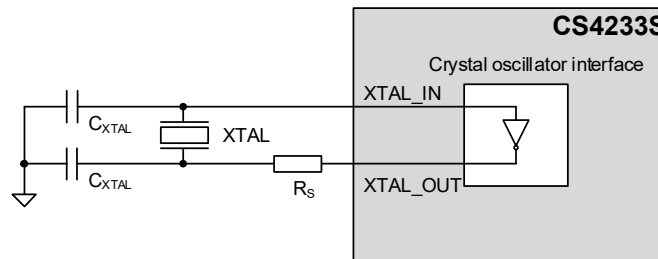
- Low-noise operational amplifiers should be used, such as Texas Instruments OPA1656. The operational amplifiers should meet the minimum performance requirements noted in [Table 5-1](#).

**Table 5-1. Op-Amp Specification**

Parameter	Specification
Input noise	<5 nV/√Hz
Unity gain bandwidth	>15 MHz
Slew rate	5 V/μs
Total harmonic distortion plus noise (THD+N)	<-128 dB

### 5.3 Crystal Component Selection

The crystal oscillator (see [Section 4.4](#)) uses an external crystal to generate the timing reference. Load capacitors are connected to the crystal as shown in [Fig. 5-6](#). A series resistor ( $R_S$ ) may also be required to configure the drive level for the selected crystal.


**Figure 5-6. Crystal Oscillator Connection**

The suitability of the selected crystal is determined by whether the gain margin and drive level are within the valid operating limits of the crystal. The gain margin and drive level can be calculated as a function of the transconductance of the crystal interface.

The transconductance of the crystal interface is dependent on the  $V_{DD\_IO2}$  operating voltage as described in [Table 3-13](#).

The recommended sequence for crystal component selection is as follows:

1. **Crystal selection.** The CS4233S is compatible with a wide variety of crystal components, including the KC3225Z series of oscillators. Note that for a reference frequency of 45.1584 MHz a custom crystal may be required.
2. **Capacitor selection.** Capacitors should be selected according to the crystal manufacturer's specification for load capacitance ( $C_L$ ). The recommended value for each  $C_{XTAL}$  capacitor is  $2 \times C_L$ .
3. **Series resistor.** In the first instance, assume the series resistor  $R_S$  is not required (0  $\Omega$ ).
4. **Gain margin calculation.** The gain margin can be calculated from the transconductance of the crystal interface and the series resistor  $R_S$ , together with the crystal characteristics. If the required gain margin is less than 5, a different crystal selection must be made (Step 1).

The gain margin is calculated as follows: 
$$\text{Gain Margin} = \frac{\text{Transconductance}}{4 \times (\text{ESR} + R_S) \times (2\pi \times f_{XTAL})^2 \times (C_0 + C_L)^2}$$

where:

Transconductance = transconductance of the crystal interface (S)

ESR = equivalent series resistance (ESR) of the crystal ( $\Omega$ )

$R_S$  = series resistance ( $\Omega$ )

$f_{XTAL}$  = resonant frequency of the crystal (Hz)

$C_L$  = load capacitance of the crystal (F)

$C_0$  = shunt capacitance of the crystal (F)

5. **Drive level calculation.** The drive level can be calculated using the crystal characteristics and the operating voltage. The operating voltage (peak voltage across the crystal) can be determined using measurement or else by

simulation. If the drive level exceeds the maximum level for the crystal, adjust the series resistor  $R_S$  to meet the required specification. Increasing  $R_S$  results in a lower voltage across the crystal and a decrease in drive level.

If the series resistor is adjusted, the gain margin must now be recalculated (Step 4). It is recommended to find the minimum series resistance that meets the required gain margin and drive level.

The drive level (W) is calculated as follows: Drive Level =  $2 \times \text{ESR} \times (\pi \times f_{\text{XTAL}} \times V \times (C_L + C_0))^2$

where:

ESR = equivalent series resistance (ESR) of the crystal ( $\Omega$ )

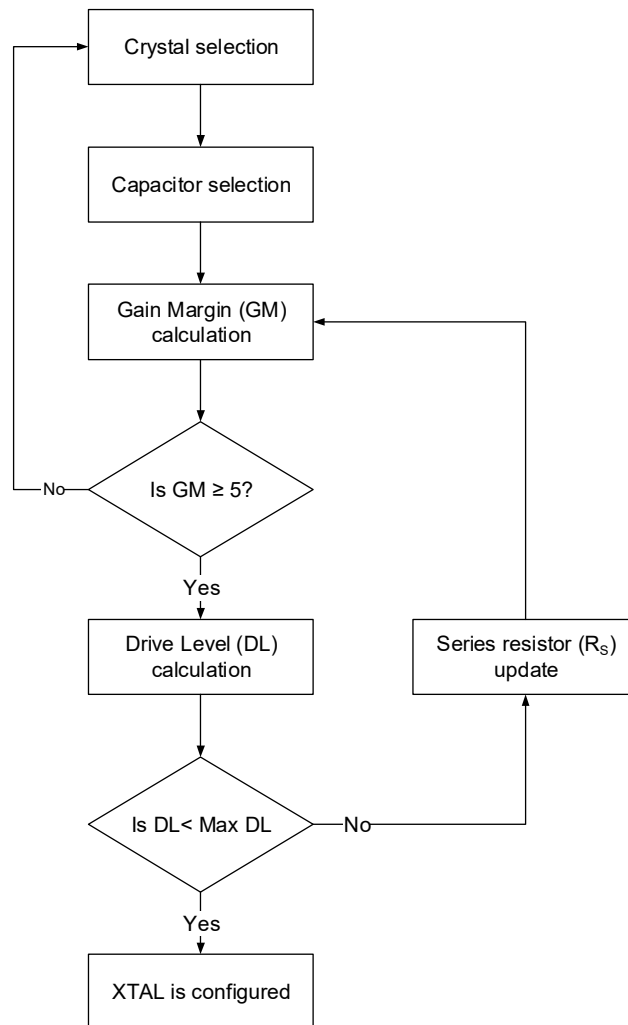
$f_{\text{XTAL}}$  = resonant frequency of the crystal (Hz)

V = Peak voltage across the crystal (V)

$C_L$  = load capacitance of the crystal (F)

$C_0$  = shunt capacitance of the crystal (F)

The sequence for crystal component selection is illustrated in [Fig. 5-7](#)



**Figure 5-7. Crystal Oscillator Component Selection**

## 6 Register Quick Reference

This section gives an overview of the control port registers. Refer to the following bit definition tables for bit assignment information.

This register view is for the CS4233S.

- The register field default values are established upon the deassertion of the **RESET** pin or following soft reset.
- A "—" represents a reserved field/access type.
- The reserved field values must not be modified.
- The registers are 16 bits wide, and only word transactions are allowed.
- All visible fields are read/write except where indicated with the following shading:

Read/write access     
  Read-only access     
  Write-only access

**Table 6-1. Block Base Addresses**

Base Address	Block Name	Register Quick Reference	Register Description Reference
0x0000 0000	<b>DEVID</b>	<a href="#">Section 6.1</a>	<a href="#">Section 7.1</a>
0x0000 0040	<b>CONFIG</b>	<a href="#">Section 6.2</a>	<a href="#">Section 7.2</a>
0x0000 0080	<b>INPUT_PATH</b>	<a href="#">Section 6.3</a>	<a href="#">Section 7.3</a>
0x0000 00C0	<b>OUTPUT_PATH</b>	<a href="#">Section 6.4</a>	<a href="#">Section 7.4</a>
0x0000 2000	<b>HGC</b>	<a href="#">Section 6.5</a>	<a href="#">Section 7.5</a>
0x0000 3D00	<b>PIN_CONFIG</b>	<a href="#">Section 6.6</a>	<a href="#">Section 7.6</a>
0x0000 3E00	<b>IRQ_CONFIG</b>	<a href="#">Section 6.7</a>	<a href="#">Section 7.7</a>

### 6.1 DEVID

Address	Register	15	14	13	12	11	10	9	8	7	6	5	4	3	2	1	0	
0x0000 0000 <a href="#">p. 71</a>	DEVID_0	DEVID_0																
		0	0	1	0	0	0	1	1	0	0	1	1	0	0	1	1	
0x0000 0002 <a href="#">p. 71</a>	DEVID_1	DEVID_1																
		0	0	0	0	0	0	0	0	0	0	0	0	0	0	1	0	0
0x0000 0004 <a href="#">p. 71</a>	REVID	—								AREVID				MTLREVID				
		0	0	0	0	0	0	0	0	1	0	1	0	0	0	0	0	0
0x0000 0022 <a href="#">p. 72</a>	SW_RESET	SW_RESET								—								
		0	0	0	0	0	0	0	0	0	0	0	0	0	0	0	0	0

### 6.2 CONFIG

Address	Register	15	14	13	12	11	10	9	8	7	6	5	4	3	2	1	0
0x0000 0040 <a href="#">p. 72</a>	CLK_CFG	—		SYSCLK_FREQ	SYSCLK_SRC	—											
		0	0	0	0	0	0	0	0	0	0	0	0	0	0	0	0
0x0000 0042 <a href="#">p. 72</a>	SAMPLE_RATE	—												SAMPLE_RATE			
		0	0	0	0	0	0	0	0	0	0	0	0	0	0	0	1
0x0000 0044 <a href="#">p. 72</a>	CHIP_ENABLE	—															
		0	0	0	0	0	0	0	0	0	0	0	0	0	0	0	0
0x0000 0048 <a href="#">p. 73</a>	ASP_CFG	—										ASP_BCLK_INV	ASP_PRIMARY	—		ASP_BCLK_FREQ	
		0	0	0	0	0	0	0	0	0	0	0	0	0	0	0	0

Address	Register	15	14	13	12	11	10	9	8	7	6	5	4	3	2	1	0
0x0000 0050 p. 73	SIGNAL_PATH_CFG	0	0	0	0	0	0	0	0	0	ASP_FSYNC_TYPE 0	ASP_TDM_SLOT 0 0 0			ASP_FORMAT 0 0 0		

## 6.3 INPUT\_PATH

Address	Register	15	14	13	12	11	10	9	8	7	6	5	4	3	2	1	0
0x0000 0080 p. 73	IN_ENABLES	0	0	0	0	0	0	0	0	0	0	0	0	0	0	IN2_ADC_EN 0	IN1_ADC_EN 0
0x0000 0082 p. 74	IN_RAMP_SUM	0	0	0	0	IN_CLIP_THRESH 0 0 0			0	0	IN_RAMP_RATE_DEC 0 1 0		0	IN_RAMP_RATE_INC 0 1 0			
0x0000 0086 p. 74	IN_FILTER	0	0	0	IN_HPF_EN 0	0	0	IN_FILTER_SEL 0 0		0	0	0	0	0	0	0	0
0x0000 008A p. 75	IN_INV	0	0	0	0	0	0	0	0	0	0	0	0	0	0	IN2_INV 0	IN1_INV 0
0x0000 0090 p. 75	IN1_VOL_CTRL	IN1_MUTE 1	0	0	0	0	0	0	IN1_VOL 0 0 0 0 0 0 0 0 0 0 0								
0x0000 0092 p. 75	IN2_VOL_CTRL	IN2_MUTE 1	0	0	0	0	0	0	IN2_VOL 0 0 0 0 0 0 0 0 0 0 0								
0x0000 00A0 p. 75	IN_VOL_UPDATE	0	0	0	0	0	0	0	0	0	0	0	0	0	0	0	IN_VU 0

## 6.4 OUTPUT\_PATH

Address	Register	15	14	13	12	11	10	9	8	7	6	5	4	3	2	1	0
0x0000 00C0 p. 76	OUT_ENABLES	0	0	0	0	0	0	0	OUT_LOAD_CFG 0	0	0	0	0	0	0	OUT2_DAC_EN 0	OUT1_DAC_EN 0
0x0000 00C2 p. 76	OUT_RAMP_SUM	0	0	0	0	0	0	0	0	0	OUT_RAMP_RATE_DEC 0 1 0		0	OUT_RAMP_RATE_INC 0 1 0			
0x0000 00C4 p. 76	OUT_DEEMPH	0	0	0	0	0	0	0	0	0	0	0	0	0	0	OUT_DEEMPH_FILTER_SEL 0	OUT_DEEMPH_EN 0
0x0000 00C6 p. 77	OUT_FILTER	0	0	0	OUT_HPF_EN 0	0	OUT_FILTER_SEL 0 0 0			0	0	0	0	0	0	0	0
0x0000 00CA p. 77	OUT_INV	0	0	0	0	0	0	0	0	0	0	0	0	0	0	OUT2_INV 1	OUT1_INV 1
0x0000 00D0 p. 77	OUT1_VOL_CTRL	OUT1_MUTE 1	0	0	0	0	0	0	OUT1_VOL 0 0 0 0 0 0 0 0 0 0 0								
0x0000 00D2 p. 78	OUT2_VOL_CTRL	OUT2_MUTE 1	0	0	0	0	0	0	OUT2_VOL 0 0 0 0 0 0 0 0 0 0 0								
0x0000 00E0 p. 78	OUT_VOL_UPDATE	0	0	0	0	0	0	0	0	0	0	0	0	0	0	0	OUT_VU 0

Address	Register	15	14	13	12	11	10	9	8	7	6	5	4	3	2	1	0	
0x0000 00E4 p. 78	SHUTDOWN_CTRL1	0	0	0	0	0	0	0	0	0	0	0	0	0	0	0	0	DAC_SHUTDOWN
0x0000 00E8 p. 78	DSD_CTRL	0	0	0	0	0	0	0	0	0	DSD_PM_SEL	DSD_PM_EN	DSD_ZERODB	DSD_OSR			DSD_EN	
0x0000 00EC p. 79	DSD_FILT	0	0	0	0	0	0	0	0	0	0	0	DSD_HPF_EN	—			0	

## 6.5 HGC

Address	Register	15	14	13	12	11	10	9	8	7	6	5	4	3	2	1	0		
0x0000 2000 p. 79	HGC_CONTROL	0	0	0	0	0	0	0	0	0	0	0	HGC_ABORT	—			HGC_INIT_UPDATE		
0x0000 2004 p. 79	HGC_STATUS	0	0	0	0	0	0	0	0	0	0	0	0	0	0	0	0	HGC_BUSY_STS	
0x0000 200C p. 80	IO_CTRL	0	0	0	0	0	DB_TIME		0	1	1	0	0	SW_TYPE	—			HGC_CTRL_INTERFERENCE	
0x0000 2010 p. 80	GPIO_STS	0	0	0	0	GPO_STS				0	0	0	0	GPI_STS			0		
0x0000 2020 p. 80	SPI_CLK	0	0	0	0	0	0	0	0	HGC_SCK_DIV			0	0	—	HGC_CLK_PHA	HGC_CLK_POL		
0x0000 2022 p. 81	SPI_CSB	0	0	0	0	HGC_CSB_IDLE_DUR			0	0	0	0	HGC_CSB_RISE_DLY		HGC_CSB_FALL_DLY				
0x0000 2100 p. 81	IN_CFG	0	0	0	0	0	0	0	0	0	0	0	IN_STEP_RAMP_EN	IN_ZC_TIMEOUT					
0x0000 2104 p. 82	IN_PATH_DLY_DIG	0	0	0	0	0	0	1	1	0	0	0	IN_INT_DIG_GAIN_DLY						
0x0000 2106 p. 82	IN_PATH_DLY_ANA	0	0	0	0	0	0	0	0	0	0	0	IN_INT_ANA_GAIN_DLY						
0x0000 2108 p. 82	IN_TM_CFG	0	0	0	0	0	1	1	1	0	0	0	0	0	0	0	0	IN_TM_EN	
0x0000 2110 p. 82	IN_TM_EN	0	0	0	0	1	1	0	0	0	0	0	0	0	0	0	0	IN2_TM_LD_EN	IN1_TM_LD_EN
0x0000 2114 p. 83	IN1_TM_THR	0	0	0	0	0	0	0	0	0	0	0	0	0	1	0	0	0	1
0x0000 2118 p. 83	IN2_TM_THR	0	0	0	0	0	0	0	0	0	0	0	0	0	1	0	0	0	1

Address	Register	15	14	13	12	11	10	9	8	7	6	5	4	3	2	1	0				
0x0000 2140 <a href="#">p. 83</a>	IN_PAD_CFG	—						IN2_PAD_LD_EN	IN1_PAD_LD_EN	—						IN2_PAD_AUTO_EN	IN1_PAD_AUTO_EN				
		0	0	0	0	0	0	0	0	0	0	0	0	0	0	0	0				
0x0000 2142 <a href="#">p. 84</a>	IN_PAD_SIGNAL	IN_PAD_LD_AVG	—										IN_PAD_LD_TIME								
		0	0	0	0	0	0	0	0	0	0	0	0	0	1	1	0	0			
0x0000 2146 <a href="#">p. 84</a>	IN1_PAD_THR	—				IN1_PAD_LOW_THR				—				IN1_PAD_HIGH_THR							
		0	0	0	0	1	0	1	0	0	0	0	0	0	0	1	1	0			
0x0000 214A <a href="#">p. 84</a>	IN2_PAD_THR	—				IN2_PAD_LOW_THR				—				IN2_PAD_HIGH_THR							
		0	0	0	0	1	0	1	0	0	0	0	0	0	0	1	1	0			
0x0000 2170 <a href="#">p. 85</a>	IN_SIG_ACT_EN	—										IN_SIG_ACT_HIGH_EN	IN_SIG_ACT_LOW_EN								
		0	0	0	0	0	0	0	0	0	0	0	0	0	0	0	0				
0x0000 2176 <a href="#">p. 85</a>	IN1_SIG_ACT_THR	—				IN1_SIG_ACT_HIGH_THR				—				IN1_SIG_ACT_LOW_THR							
		0	0	0	0	1	0	1	0	0	0	0	0	0	0	1	1	1			
0x0000 217A <a href="#">p. 85</a>	IN2_SIG_ACT_THR	—				IN2_SIG_ACT_HIGH_THR				—				IN2_SIG_ACT_LOW_THR							
		0	0	0	0	1	0	1	0	0	0	0	0	0	0	1	1	1			
0x0000 2200 <a href="#">p. 86</a>	IN1_CFG_SPI	—				IN1_SPI_POSITION				—				IN1_BIT_PATT_LENGTH							
		0	0	0	0	0	0	0	0	0	0	0	0	0	0	0	0	0			
0x0000 2202 <a href="#">p. 86</a>	IN1_CFG_GPIO	—			IN1_GPI_POL	—	IN1_GPI_SEL			—				IN1_GPO4_SEL	IN1_GPO3_SEL	IN1_GPO2_SEL	IN1_GPO1_SEL				
		0	0	0	0	0	0	0	0	0	0	0	0	0	0	0	0				
0x0000 2204 <a href="#">p. 86</a>	IN2_CFG_SPI	—				IN2_SPI_POSITION				—				IN2_BIT_PATT_LENGTH							
		0	0	0	0	0	0	0	0	0	0	0	0	0	0	0	0				
0x0000 2206 <a href="#">p. 87</a>	IN2_CFG_GPIO	—			IN2_GPI_POL	—	IN2_GPI_SEL			—				IN2_GPO4_SEL	IN2_GPO3_SEL	IN2_GPO2_SEL	IN2_GPO1_SEL				
		0	0	0	0	0	0	0	0	0	0	0	0	0	0	0	0				
0x0000 2220 <a href="#">p. 87</a>	IN1_BIT_PATT_0	IN1_BIT_PATT_0																			
		0	0	0	0	0	0	0	0	0	0	0	0	0	0	0	0				
0x0000 2222 <a href="#">p. 87</a>	IN1_BIT_PATT_1	IN1_BIT_PATT_1																			
		0	0	0	0	0	0	0	0	0	0	0	0	0	0	0	0				
0x0000 2224 <a href="#">p. 88</a>	IN1_EXT_GAIN	—				IN1_EXT_ANA_GAIN															
		0	0	0	0	0	0	0	0	0	0	0	0	0	0	0	0				
0x0000 2226 <a href="#">p. 88</a>	IN1_INT_GAIN	IN1_UPDATE	—	IN1_INT_ANA_GAIN			—											IN1_INT_DIG_GAIN			
		0	0	0	0	0	0	0	0	0	0	0	0	0	0	0	0				
0x0000 2228 <a href="#">p. 88</a>	IN2_BIT_PATT_0	IN2_BIT_PATT_0																			
		0	0	0	0	0	0	0	0	0	0	0	0	0	0	0	0				
0x0000 222A <a href="#">p. 88</a>	IN2_BIT_PATT_1	IN2_BIT_PATT_1																			
		0	0	0	0	0	0	0	0	0	0	0	0	0	0	0	0				
0x0000 222C <a href="#">p. 89</a>	IN2_EXT_GAIN	—				IN2_EXT_ANA_GAIN															
		0	0	0	0	0	0	0	0	0	0	0	0	0	0	0	0				
0x0000 222E <a href="#">p. 89</a>	IN2_INT_GAIN	IN2_UPDATE	—	IN2_INT_ANA_GAIN			—											IN2_INT_DIG_GAIN			
		0	0	0	0	0	0	0	0	0	0	0	0	0	0	0	0				
0x0000 2260 <a href="#">p. 89</a>	IN1_LOW_BIT_PATT_0	IN1_LOW_BIT_PATT_0																			
		0	0	0	0	0	0	0	0	0	0	0	0	0	0	0	0				
0x0000 2262 <a href="#">p. 89</a>	IN1_LOW_BIT_PATT_1	IN1_LOW_BIT_PATT_1																			
		0	0	0	0	0	0	0	0	0	0	0	0	0	0	0	0				
0x0000 2264 <a href="#">p. 90</a>	IN1_LOW_EXT_GAIN	—				IN1_LOW_EXT_ANA_GAIN															
		0	0	0	0	0	0	0	0	0	0	0	0	0	0	0	0				

Address	Register	15	14	13	12	11	10	9	8	7	6	5	4	3	2	1	0		
0x0000 2266 p. 90	IN1_LOW_INT_GAIN	IN1_LOW_UPDATE 0	— 0	IN1_LOW_INT_ANA_GAIN 0 0	— 0 0	— 0 0	— 0 0	— 0 0	IN1_LOW_INT_DIG_GAIN 0 0 0 0 0 0 0 0 0 0 0 0										
0x0000 2268 p. 90	IN2_LOW_BIT_PATT_0	IN2_LOW_BIT_PATT_0 0 0 0 0 0 0 0 0 0 0 0 0 0 0 0 0 0 0																	
0x0000 226A p. 90	IN2_LOW_BIT_PATT_1	IN2_LOW_BIT_PATT_1 0 0 0 0 0 0 0 0 0 0 0 0 0 0 0 0 0 0																	
0x0000 226C p. 91	IN2_LOW_EXT_GAIN	— 0 0 0 0 0 0						IN2_LOW_EXT_ANA_GAIN 0 0 0 0 0 0 0 0 0 0 0 0 0 0 0 0											
0x0000 226E p. 91	IN2_LOW_INT_GAIN	IN2_LOW_UPDATE 0	— 0	IN2_LOW_INT_ANA_GAIN 0 0	— 0 0	— 0 0	— 0 0	— 0 0	IN2_LOW_INT_DIG_GAIN 0 0 0 0 0 0 0 0 0 0 0 0										
0x0000 22C0 p. 91	IN1_HIGH_BIT_PATT_0	IN1_HIGH_BIT_PATT_0 0 0 0 0 0 0 0 0 0 0 0 0 0 0 0 0 0 0																	
0x0000 22C2 p. 91	IN1_HIGH_BIT_PATT_1	IN1_HIGH_BIT_PATT_1 0 0 0 0 0 0 0 0 0 0 0 0 0 0 0 0 0 0																	
0x0000 22C4 p. 92	IN1_HIGH_EXT_GAIN	— 0 0 0 0 0 0						IN1_HIGH_EXT_ANA_GAIN 0 0 0 0 0 0 0 0 0 0 0 0 0 0 0 0											
0x0000 22C6 p. 92	IN1_HIGH_INT_GAIN	IN1_HIGH_UPDATE 0	— 0	IN1_HIGH_INT_ANA_GAIN 0 0	— 0 0	— 0 0	— 0 0	— 0 0	IN1_HIGH_INT_DIG_GAIN 0 0 0 0 0 0 0 0 0 0 0 0										
0x0000 22C8 p. 92	IN2_HIGH_BIT_PATT_0	IN2_HIGH_BIT_PATT_0 0 0 0 0 0 0 0 0 0 0 0 0 0 0 0 0 0 0																	
0x0000 22CA p. 92	IN2_HIGH_BIT_PATT_1	IN2_HIGH_BIT_PATT_1 0 0 0 0 0 0 0 0 0 0 0 0 0 0 0 0 0 0																	
0x0000 22CC p. 93	IN2_HIGH_EXT_GAIN	— 0 0 0 0 0 0						IN2_HIGH_EXT_ANA_GAIN 0 0 0 0 0 0 0 0 0 0 0 0 0 0 0 0											
0x0000 22CE p. 93	IN2_HIGH_INT_GAIN	IN2_HIGH_UPDATE 0	— 0	IN2_HIGH_INT_ANA_GAIN 0 0	— 0 0	— 0 0	— 0 0	— 0 0	IN2_HIGH_INT_DIG_GAIN 0 0 0 0 0 0 0 0 0 0 0 0										
0x0000 2500 p. 93	OUT_CFG	— 0 0 0 0 0 0 0 0 0 0										OUT_STEP_RAMP_EN 0	OUT_ZC_TIMEOUT 0 1 1 1						
0x0000 2504 p. 94	OUT_PATH_EXT_DLY	— 0 0 0 0 0 0						OUT_EXT_GAIN_DLY 0 0 0 0 0 0 0 0 0 0 0 0 1 1 0 1 0 0 1											
0x0000 2600 p. 94	OUT1_CFG_SPI	— 0 0 0 0				OUT1_SPI_POSITION 0 0 0 0				— 0 0		OUT1_BIT_PATT_LENGTH 0 0 0 0 0 0 0 0 0 0 0 0							
0x0000 2602 p. 94	OUT1_CFG_GPIO	— 0 0 0			OUT1_GPI_POL 0	— 0 0 0 0 0 0 0 0 0 0								OUT1_GPO4_SEL 0	OUT1_GPO3_SEL 0	OUT1_GPO2_SEL 0	OUT1_GPO1_SEL 0		
0x0000 2604 p. 95	OUT2_CFG_SPI	— 0 0 0 0				OUT2_SPI_POSITION 0 0 0 0				— 0 0		OUT2_BIT_PATT_LENGTH 0 0 0 0 0 0 0 0 0 0 0 0							
0x0000 2606 p. 95	OUT2_CFG_GPIO	— 0 0 0			OUT2_GPI_POL 0	— 0 0 0 0 0 0 0 0 0 0								OUT2_GPO4_SEL 0	OUT2_GPO3_SEL 0	OUT2_GPO2_SEL 0	OUT2_GPO1_SEL 0		
0x0000 2620 p. 95	OUT1_BIT_PATT_0	OUT1_BIT_PATT_0 0 0 0 0 0 0 0 0 0 0 0 0 0 0 0 0 0 0																	
0x0000 2622 p. 96	OUT1_BIT_PATT_1	OUT1_BIT_PATT_1 0 0 0 0 0 0 0 0 0 0 0 0 0 0 0 0 0 0																	
0x0000 2624 p. 96	OUT1_VOL_ANA	— 0 0 0 0 0 0						OUT1_ANA_GAIN 0 0 0 0 0 0 0 0 0 0 0 0 0 0 0 0											

Address	Register	15	14	13	12	11	10	9	8	7	6	5	4	3	2	1	0	
0x0000 2626 p. 96	OUT1_VOL_DIG	OUT1_UPDATE 0	0	0	0	0	0	0	OUT1_DIG_GAIN									
0x0000 2628 p. 96	OUT2_BIT_PATT_0	0							OUT2_BIT_PATT_0									
0x0000 262A p. 97	OUT2_BIT_PATT_1	0							OUT2_BIT_PATT_1									
0x0000 262C p. 97	OUT2_VOL_ANA	0							OUT2_ANA_GAIN									
0x0000 262E p. 97	OUT2_VOL_DIG	OUT2_UPDATE 0	0	0	0	0	0	0	OUT2_DIG_GAIN									
0x0000 2900 p. 97	AUX1_CFG	0				0				AUX1_SPL_POSITION 0 0 0			0		AUX1_BIT_PATT_LENGTH 0 0 0 0 0 0			
0x0000 2904 p. 98	AUX2_CFG	0				0				AUX2_SPL_POSITION 0 0 0			0		AUX2_BIT_PATT_LENGTH 0 0 0 0 0 0			
0x0000 2920 p. 98	AUX1_BIT_PATT_0	0																
0x0000 2922 p. 98	AUX1_BIT_PATT_1	0																
0x0000 2924 p. 98	AUX2_BIT_PATT_0	0																
0x0000 2926 p. 98	AUX2_BIT_PATT_1	0																

## 6.6 PIN\_CONFIG

Address	Register	15	14	13	12	11	10	9	8	7	6	5	4	3	2	1	0			
0x0000 3D1C p. 99	PAD_IRQ_CFG	IRQ_OP_CFG 0	0						GPIO1_IRQ_EN 0		GPIO2_IRQ_EN 0		0		CONFIG4_IRQ_EN 0		SPL_SCK_IRQ_EN 0		0	

## 6.7 IRQ\_CONFIG

Address	Register	15	14	13	12	11	10	9	8	7	6	5	4	3	2	1	0
0x0000 3E04 p. 99	IRQ_STS	0															
0x0000 3E1C p. 99	IRQ_ADC_EVENT_INT	IN2_SIG_ACT_LOW_INT 0	IN1_SIG_ACT_LOW_INT 0	IN2_SIG_ACT_HIGH_INT 0	IN1_SIG_ACT_HIGH_INT 0	IN2_PAD_LOW_INT 0	IN1_PAD_LOW_INT 0	IN2_PAD_HIGH_INT 0	IN1_PAD_HIGH_INT 0	GAIN_CONFLICT_INT 0	0		0		IN2_CLIP_WARN_INT 0	IN1_CLIP_WARN_INT 0	0
0x0000 3E1E p. 100	IRQ_HGC_EVENT_INT	0											HGC_SPI_ERROR_INT 0	HGC_ABORT_ERROR_INT 0	0	HGC_ERROR_INT 0	HGC_DONE_INT 0
0x0000 3E2C p. 101	IRQ_ADC_EVENT_MASK	IN2_SIG_ACT_LOW_MASK 1	IN1_SIG_ACT_LOW_MASK 1	IN2_SIG_ACT_HIGH_MASK 0	IN1_SIG_ACT_HIGH_MASK 0	IN2_PAD_LOW_MASK 1	IN1_PAD_LOW_MASK 1	IN2_PAD_HIGH_MASK 1	IN1_PAD_HIGH_MASK 1	GAIN_CONFLICT_MASK 1	0		0		IN2_CLIP_WARN_MASK 0	IN1_CLIP_WARN_MASK 0	0
0x0000 3E2E p. 101	IRQ_HGC_EVENT_MASK	0											HGC_SPI_ERROR_MASK 1	HGC_ABORT_MASK 1	0	HGC_ERROR_MASK 1	HGC_DONE_MASK 1

Address	Register	15	14	13	12	11	10	9	8	7	6	5	4	3	2	1	0
0x0000 3E5C	IRQ_ADC_EVENT_STS	IN2_SIG_ACT_LOW_STS	IN1_SIG_ACT_LOW_STS	IN2_SIG_ACT_HIGH_STS	IN1_SIG_ACT_HIGH_STS	IN2_PAD_LOW_STS	IN1_PAD_LOW_STS	IN2_PAD_HIGH_STS	IN1_PAD_HIGH_STS	—				IN2_CLIP_WARN_STS	IN1_CLIP_WARN_STS	—	
<a href="#">p. 102</a>		0	0	0	0	0	0	0	0	0	0	0	0	0	0	0	0



**7.1.4 SW\_RESET**
**Address: 0x0000 0022**

WO	15	14	13	12	11	10	9	8	7	6	5	4	3	2	1	0
	SW_RESET								—							
Default	0	0	0	0	0	0	0	0	0	0	0	0	0	0	0	0

Bits	Name	Description
15:8	SW_RESET	Software Reset. Writing 0x5A triggers a reset. 0x00 = (Default) No action 0x01–0x59 = Reserved 0x5A = Software reset 0x5B–0xFF = Reserved
7:0	—	Reserved

**7.2 CONFIG**
**7.2.1 CLK\_CFG**
**Address: 0x0000 0040**

RW	15	14	13	12	11	10	9	8	7	6	5	4	3	2	1	0
	—		SYSCLK_FREQ	SYSCLK_SRC	—											
Default	0	0	0	0	0	0	0	0	0	0	0	0	0	0	0	0

Bits	Name	Description
15:14	—	Reserved
13	SYSCLK_FREQ	System clock frequency. 0 = (Default) 24.576/22.5792 MHz 1 = 49.152/45.1584 MHz
12	SYSCLK_SRC	System clock source. If XTAL is selected, the MCLK is the output clock. 0 = (Default) MCLK input 1 = XTAL input
11:0	—	Reserved

**7.2.2 SAMPLE\_RATE**
**Address: 0x0000 0042**

RW	15...8	7	6	5	4	3	2	1	0	
	—	—							SAMPLE_RATE	
Default	0x00	0	0	0	0	0	0	0	1	

Bits	Name	Description
15:3	—	Reserved
2:0	SAMPLE_RATE	Audio sample frequency. Note the sample rate must be integer-related to the system clock frequency. Auto-detect is only valid if sample rate = 16-192 kHz, and the ASP is in Secondary Mode. 000 = 32 kHz 001 = (Default) 48/44.1 kHz 010 = 96/88.2 kHz 011 = 192/176.4 kHz 100 = 384/356.8 kHz 101 = Reserved 110 = Auto-detect 111 = 16 kHz

**7.2.3 CHIP\_ENABLE**
**Address: 0x0000 0044**

RW	15...8	7	6	5	4	3	2	1	0	
	—	—							GLOBAL_EN	
Default	0x00	0	0	0	0	0	0	0	0	

Bits	Name	Description
15:1	—	Reserved
0	GLOBAL_EN	Global enable. Set to 1 to configure and enable all functions. Clear to 0 to disable. Note the clocking and ASP control registers are only valid on the rising edge of GLOBAL_EN. It is recommended to select the disabled state (GLOBAL_EN=0) before writing to these registers.

**7.2.4 ASP\_CFG**
**Address: 0x0000 0048**

RW	15...8	7	6	5	4	3	2	1	0
	—	—	ASP_BCLK_INV	ASP_PRIMARY	—		ASP_BCLK_FREQ		
Default	0x00	0	0	0	0	0	0	0	0

Bits	Name	Description
15:7	—	Reserved
6	ASP_BCLK_INV	ASP BCLK polarity. Selects the valid BCLK edge for data sampling. In non-inverted mode, DIN data is valid on BCLK rising edge. DOOUT data is driven on BCLK falling edge (TDM half-cycle mode) or rising edge (TDM full-cycle mode). In inverted mode, DIN data is valid on BCLK falling edge. DOOUT data is driven on BCLK rising edge (TDM half-cycle mode) or falling edge (TDM full-cycle mode). 0 = (Default) Non-inverted 1 = Inverted
5	ASP_PRIMARY	ASP Primary/Secondary Mode select. In ASP Primary Mode, BCLK and FSYNC are outputs. In ASP Secondary Mode, BCLK and FSYNC are inputs. 0 = (Default) Secondary Mode 1 = Primary Mode
4:2	—	Reserved
1:0	ASP_BCLK_FREQ	ASP BCLK frequency. The BCLK frequency must be high enough to support the required number of data bits at the selected sample rate. Only valid in ASP Primary Mode. Note the BCLK frequency is integer-related to the system clock frequency i.e., multiples of 3.072 MHz for 24.576 / 49.152 MHz system clock, or multiples of 2.8224 MHz for 22.5792 / 45.1584 MHz system clock. 00 = (Default) 3.072/2.8224 MHz 01 = 6.144/5.6448 MHz 10 = 12.288/11.2896 MHz 11 = 24.576/22.5792 MHz

**7.2.5 SIGNAL\_PATH\_CFG**
**Address: 0x0000 0050**

RW	15...8	7	6	5	4	3	2	1	0
	—	—	ASP_FSYNC_TYPE	ASP_TDM_SLOT		ASP_FORMAT			
Default	0x00	0	0	0	0	0	0	0	0

Bits	Name	Description
15:7	—	Reserved
6	ASP_FSYNC_TYPE	Configure ASP_FSYNC as pulse or square wave (50% duty cycle) in TDM mode. Only applicable when ASP is in Primary Mode. 0 = (Default) FSYNC Pulse 1 = FSYNC Square Wave
5:3	ASP_TDM_SLOT	TDM slot select. Configures which TDM slots are used in TDM maximum-time-slots mode. 000 = (Default) Slots 0-1 001 = Slots 2-3 010 = Slots 4-5 011 = Slots 6-7 100 = Slots 8-9 101 = Slots 10-11 110 = Slots 12-13 111 = Slots 14-15
2:0	ASP_FORMAT	ASP data format. Selects how the audio samples are arranged within the FSYNC frame. 000 = (Default) I2S Mode 001 = Left-Justified Mode 010–100 = Reserved 101 = TDM Mode maximum time slots, full cycle 110 = TDM Mode maximum time slots, half cycle 111 = TDM Mode minimum time slots

**7.3 INPUT\_PATH**
**7.3.1 IN\_ENABLES**
**Address: 0x0000 0080**

RW	15...8	7	6	5	4	3	2	1	0	
	—	—					IN2_ADC_EN	IN1_ADC_EN	—	
Default	0x00	0	0	0	0	0	0	0	0	

Bits	Name	Description
15:2	—	Reserved

Bits	Name	Description
1	IN2_ADC_EN	Channel 2 input enable. Note that Channels 1-2 should always be enabled/disabled as a pair. 0 = (Default) Disabled 1 = Enabled
0	IN1_ADC_EN	Channel 1 input enable. Note that Channels 1-2 should always be enabled/disabled as a pair. 0 = (Default) Disabled 1 = Enabled

### 7.3.2 IN\_RAMP\_SUM

**Address: 0x0000 0082**

RW	15	14	13	12	11	10	9	8	7	6	5	4	3	2	1	0		
	—				IN_CLIP_THRESH				—	IN_RAMP_RATE_DEC				—	IN_RAMP_RATE_INC			
Default	0	0	0	0	0	0	0	0	0	0	1	0	0	0	1	0		

Bits	Name	Description
15:12	—	Reserved
11:8	IN_CLIP_THRESH	Input clip-warning threshold. 0x0 = (Default) 0.0 dBFS 0x1 = -0.125 dBFS 0x2 = -0.25 dBFS 0x3 = -0.5 dBFS 0x4 = -1.0 dBFS 0x5 = -3.0 dBFS 0x6 = -6.0 dBFS 0x7-0xF = Reserved
7	—	Reserved
6:4	IN_RAMP_RATE_DEC	ADC input volume Decrease Ramp Rate (ms/6 dB), used for gain changes. This field should not be changed while a volume ramp is in progress. 000 = 0 ms 001 = 0.5 ms 010 = (Default) 1 ms 011 = 2 ms 100 = 4 ms 101 = 8 ms 110 = 15 ms 111 = 30 ms
3	—	Reserved
2:0	IN_RAMP_RATE_INC	ADC input volume Increase Ramp Rate (ms/6 dB), used for gain changes. This field should not be changed while a volume ramp is in progress. 000 = 0 ms 001 = 0.5 ms 010 = (Default) 1 ms 011 = 2 ms 100 = 4 ms 101 = 8 ms 110 = 15 ms 111 = 30 ms

### 7.3.3 IN\_FILTER

**Address: 0x0000 0086**

RW	15	14	13	12	11	10	9	8	7	6	5	4	3	2	1	0
	—			IN_HPF_EN	—			IN_FILTER_SEL		—						
Default	0	0	0	0	0	0	0	0	0	0	0	0	0	0	0	0

Bits	Name	Description
15:13	—	Reserved
12	IN_HPF_EN	High-pass filter enable. 0 = (Default) HPF disabled 1 = HPF enabled
11:10	—	Reserved
9:8	IN_FILTER_SEL	Digital filter select. Configures the decimation filter. 00 = (Default) Minimum phase, Slow roll-off 01 = Minimum phase, Fast roll-off 10 = Linear phase, Slow roll-off 11 = Linear phase, Fast roll-off
7:0	—	Reserved

**7.3.4 IN\_INV**
**Address: 0x0000 008A**

RW	15...8	7	6	5	4	3	2	1	0
	—				—			IN2_INV	IN1_INV
Default	0x00	0	0	0	0	0	0	0	0

Bits	Name	Description
15:2	—	Reserved
1	IN2_INV	Channel 2 ADC invert. 0 = (Default) No inversion 1 = ADC data invert
0	IN1_INV	Channel 1 ADC invert. 0 = (Default) No inversion 1 = ADC data invert

**7.3.5 IN1\_VOL\_CTRL**
**Address: 0x0000 0090**

RW	15	14	13	12	11	10	9	8	7	6	5	4	3	2	1	0
	IN1_MUTE			—									IN1_VOL			
Default	1	0	0	0	0	0	0	0	0	0	0	0	0	0	0	0

Bits	Name	Description
15	IN1_MUTE	Channel 1 input mute. 0 = Unmute 1 = (Default) Mute
14:9	—	Reserved
8:0	IN1_VOL	Channel 1 input digital volume, -127.5 dB to +30 dB in 0.5 dB steps. 0x000 = (Default) 0.0 dB 0x001 = -0.5 dB ... 0x0FF = -127.5 dB 0x100 = Reserved 0x101 = 0.5 dB 0x102 = 1.0 dB ... 0x13C = 30.0 dB 0x13D-0x1FF = Reserved

**7.3.6 IN2\_VOL\_CTRL**
**Address: 0x0000 0092**

RW	15	14	13	12	11	10	9	8	7	6	5	4	3	2	1	0
	IN2_MUTE			—									IN2_VOL			
Default	1	0	0	0	0	0	0	0	0	0	0	0	0	0	0	0

Bits	Name	Description
15	IN2_MUTE	Channel 2 input mute. 0 = Unmute 1 = (Default) Mute
14:9	—	Reserved
8:0	IN2_VOL	Channel 2 input digital volume, -127.5 dB to +30 dB in 0.5 dB steps. 0x000 = (Default) 0.0 dB 0x001 = -0.5 dB ... 0x0FF = -127.5 dB 0x100 = Reserved 0x101 = 0.5 dB 0x102 = 1.0 dB ... 0x13C = 30.0 dB 0x13D-0x1FF = Reserved

**7.3.7 IN\_VOL\_UPDATE**
**Address: 0x0000 00A0**

WO	15...8	7	6	5	4	3	2	1	0
	—				—				IN_VU
Default	0x00	0	0	0	0	0	0	0	0

Bits	Name	Description
15:1	—	Reserved
0	IN_VU	Global ADC input volume update trigger. 0 = (Default) No action 1 = Write 1 to trigger an update of all input volume/mute registers

## 7.4 OUTPUT\_PATH

### 7.4.1 OUT\_ENABLES

**Address: 0x0000 00C0**

RW	15	14	13	12	11	10	9	8	7	6	5	4	3	2	1	0
	—							OUT_LOAD_CFG	—				OUT2_DAC_EN	OUT1_DAC_EN		
Default	0	0	0	0	0	0	0	0	0	0	0	0	0	0	0	0

Bits	Name	Description
15:9	—	Reserved
8	OUT_LOAD_CFG	Output driving configuration. 0 = (Default) 3k load 1 = 10k load
7:2	—	Reserved
1	OUT2_DAC_EN	Channel 2 output enable. 0 = (Default) Disabled 1 = Enabled
0	OUT1_DAC_EN	Channel 1 output enable. 0 = (Default) Disabled 1 = Enabled

### 7.4.2 OUT\_RAMP\_SUM

**Address: 0x0000 00C2**

RW	15...8	7	6	5	4	3	2	1	0
	—	—	OUT_RAMP_RATE_DEC			—	OUT_RAMP_RATE_INC		
Default	0x00	0	0	1	0	0	0	1	0

Bits	Name	Description
15:7	—	Reserved
6:4	OUT_RAMP_RATE_DEC	DAC output volume decrease Ramp Rate (ms/6 dB), used for gain changes. This field should not be changed while a volume ramp is in progress. 000 = 0 ms 001 = 0.5 ms 010 = (Default) 1 ms 011 = 2 ms 100 = 4 ms 101 = 8 ms 110 = 15 ms 111 = 30 ms
3	—	Reserved
2:0	OUT_RAMP_RATE_INC	DAC output volume increase Ramp Rate (ms/6 dB), used for gain changes. This field should not be changed while a volume ramp is in progress. 000 = 0 ms 001 = 0.5 ms 010 = (Default) 1 ms 011 = 2 ms 100 = 4 ms 101 = 8 ms 110 = 15 ms 111 = 30 ms

### 7.4.3 OUT\_DEEMPH

**Address: 0x0000 00C4**

RW	15...8	7	6	5	4	3	2	1	0
	—	—					OUT_DEEMPH_FILT_SEL	OUT_DEEMPH_EN	
Default	0x00	0	0	0	0	0	0	0	

Bits	Name	Description
15:2	—	Reserved
1	OUT_DEEMPH_FILT_SEL	Deemphasis filter sample-rate selection. 0 = (Default) 44.1 kHz 1 = 48.0 kHz
0	OUT_DEEMPH_EN	Deemphasis filter enable. 0 = (Default) Deemphasis disabled 1 = Deemphasis enabled

**7.4.4 OUT\_FILTER**
**Address: 0x0000 00C6**

RW	15	14	13	12	11	10	9	8	7	6	5	4	3	2	1	0
	—			OUT_HP_F_EN	—	OUT_FILTER_SEL			—							
Default	0	0	0	0	0	0	0	0	0	0	0	0	0	0	0	0

Bits	Name	Description
15:13	—	Reserved
12	OUT_HP_F_EN	High-pass filter enable. 0 = (Default) HPF disabled 1 = HPF enabled
11	—	Reserved
10:8	OUT_FILTER_SEL	Digital filter select. Configures the interpolation filter. 000 = (Default) Minimum phase, Slow roll-off (44.1 kHz-192 kHz) 001 = Minimum phase, Fast roll-off (16 kHz-48 kHz)/Balanced roll-off (88.2 kHz-384 kHz) 010 = Linear phase, Slow roll-off (44.1 kHz-192 kHz) 011 = Linear phase, Fast roll-off (16 kHz-48 kHz)/Balanced roll-off (88.2 kHz-384 kHz) 100 = Reserved 101 = Minimum phase, Fast roll-off (88.2 kHz-384 kHz) 110 = Reserved 111 = Linear phase, Fast roll-off (88.2 kHz-384 kHz)
7:0	—	Reserved

**7.4.5 OUT\_INV**
**Address: 0x0000 00CA**

RW	15...8	7	6	5	4	3	2	1	0
	—							OUT2_INV	OUT1_INV
Default	0x00	0	0	0	0	0	0	1	1

Bits	Name	Description
15:2	—	Reserved
1	OUT2_INV	Channel 2 DAC invert. 0 = No inversion 1 = (Default) DAC data invert
0	OUT1_INV	Channel 1 DAC invert. 0 = No inversion 1 = (Default) DAC data invert

**7.4.6 OUT1\_VOL\_CTRL**
**Address: 0x0000 00D0**

RW	15	14	13	12	11	10	9	8	7	6	5	4	3	2	1	0
	OUT1_MUTE	—							OUT1_VOL							
Default	1	0	0	0	0	0	0	0	0	0	0	0	0	0	0	0

Bits	Name	Description
15	OUT1_MUTE	DAC output Channel 1 mute. 0 = Unmute 1 = (Default) Mute
14:8	—	Reserved
7:0	OUT1_VOL	DAC output Channel 1 volume, -127.5 dB to 0 dB in 0.5 dB steps. 0x00 = (Default) 0.0 dB 0x01 = -0.5 dB ... 0xFF = -127.5 dB

**7.4.7 OUT2\_VOL\_CTRL**
**Address: 0x0000 00D2**

RW	15	14	13	12	11	10	9	8	7	6	5	4	3	2	1	0
	OUT2_MUTE	—							OUT2_VOL							
Default	1	0	0	0	0	0	0	0	0	0	0	0	0	0	0	0

Bits	Name	Description
15	OUT2_MUTE	DAC output Channel 2 mute. 0 = Unmute 1 = (Default) Mute
14:8	—	Reserved
7:0	OUT2_VOL	DAC output Channel 2 volume, -127.5 dB to 0 dB in 0.5 dB steps. 0x00 = (Default) 0.0 dB ... 0x01 = -0.5 dB 0xFF = -127.5 dB

**7.4.8 OUT\_VOL\_UPDATE**
**Address: 0x0000 00E0**

WO	15...8	7	6	5	4	3	2	1	0
	—	—							OUT_VU
Default	0x00	0	0	0	0	0	0	0	0

Bits	Name	Description
15:1	—	Reserved
0	OUT_VU	Global output volume update trigger. 0 = (Default) No action 1 = Write 1 to trigger an update of all output volume/mute registers

**7.4.9 SHUTDOWN\_CTRL1**
**Address: 0x0000 00E4**

RW	15...8	7	6	5	4	3	2	1	0
	—	—							DAC_SHUTDOWN
Default	0x00	0	0	0	0	0	0	0	0

Bits	Name	Description
15:1	—	Reserved
0	DAC_SHUTDOWN	DAC reference shutdown control. Can be used to minimize power consumption if all output paths are disabled. 0 = (Default) Enable DAC reference 1 = Shutdown DAC reference

**7.4.10 DSD\_CTRL**
**Address: 0x0000 00E8**

RW	15...8	7	6	5	4	3	2	1	0
	—	—	DSD_PM_SEL	DSD_PM_EN	DSD_ZERODB	DSD_OSR		DSD_EN	
Default	0x00	0	0	0	0	0	0	0	0

Bits	Name	Description
15:7	—	Reserved
6	DSD_PM_SEL	DSD phase modulation mode clock rate select. 0 = (Default) DSD clock at 2 x OSR rate 1 = DSD clock at OSR rate
5	DSD_PM_EN	DSD phase modulation enable. 0 = (Default) Disabled 1 = Enabled
4	DSD_ZERODB	DSD input 0 dB level. 0 = (Default) SACD +3.1 dB level matches PCM 0 dBFS level 1 = SACD 0 dB level matches PCM 0 dBFS level

Bits	Name	Description
3:1	DSD_OSR	DSD oversample rate (OSR). 000 = (Default) 64 Fs 001 = 128 Fs 010 = 256 Fs 011–111 = Reserved
0	DSD_EN	DSD interface enable. Selects ASP or DSD signal path. 0 = (Default) Select ASP path 1 = Select DSD path

### 7.4.11 DSD\_FILT

**Address: 0x0000 00EC**

RW	15...8	7	6	5	4	3	2	1	0
	—		—		DSD_HPF_EN		—		
Default	0x00	0	0	0	1	0	0	0	0

Bits	Name	Description
15:5	—	Reserved
4	DSD_HPF_EN	DSD high-pass filter enable. 0 = Disabled 1 = (Default) Enabled
3:0	—	Reserved

## 7.5 HGC

### 7.5.1 HGC\_CONTROL

**Address: 0x0000 2000**

WO	15...8	7	6	5	4	3	2	1	0
	—		—		HGC_ABORT		—		HGC_INIT_UPDATE
Default	0x00	0	0	0	0	0	0	0	0

Bits	Name	Description
15:5	—	Reserved
4	HGC_ABORT	Abort gain updates. Write 1 to abort any pending gain updates. Note that any updates already in progress will complete as normal and are not aborted. 0 = (Default) No action 1 = Write 1 to abort gain updates
3:1	—	Reserved
0	HGC_INIT_UPDATE	Initialize gain settings. Write 1 to transmit the SPI bit patterns and initialize all gain settings. Note the zero-cross detection is not applied when initializing gain settings. 0 = (Default) No action 1 = Write 1 to initialize gain settings

### 7.5.2 HGC\_STATUS

**Address: 0x0000 2004**

RO	15...8	7	6	5	4	3	2	1	0
	—				—				HGC_BUSY_STS
Default	0x00	0	0	0	0	0	0	0	0

Bits	Name	Description
15:1	—	Reserved
0	HGC_BUSY_STS	Busy status. Indicates gain updates are pending for one or more audio channels. 0 = (Default) Idle 1 = Busy



**7.5.6 SPI\_CS**
**Address: 0x0000 2022**

RW	15	14	13	12	11	10	9	8	7	6	5	4	3	2	1	0
	—				HGC_CSB_IDLE_DUR				HGC_CSB_RISE_DLY				HGC_CSB_FALL_DLY			
Default	0	0	0	0	0	0	0	0	0	0	0	0	0	0	0	0

Bits	Name	Description																
15:12	—	Reserved																
11:8	HGC_CSB_IDLE_DUR	<p>Minimum idle duration between SPI transactions (from CS rising edge to CS falling edge). The duration is defined in system-clock cycles.</p> <p>For 48 kHz-related sample rates, the system-clock period is 1/24.576 MHz. For 44.1 kHz-related sample rates, the system-clock period is 1/22.5792 MHz.</p> <table> <tr> <td>0x0 = (Default) 32 clock cycles</td> <td>0x8 = 96 clock cycles</td> </tr> <tr> <td>0x1 = 36 clock cycles</td> <td>0x9 = 128 clock cycles</td> </tr> <tr> <td>0x2 = 40 clock cycles</td> <td>0xA = 160 clock cycles</td> </tr> <tr> <td>0x3 = 44 clock cycles</td> <td>0xB = 224 clock cycles</td> </tr> <tr> <td>0x4 = 48 clock cycles</td> <td>0xC = 288 clock cycles</td> </tr> <tr> <td>0x5 = 56 clock cycles</td> <td>0xD = 416 clock cycles</td> </tr> <tr> <td>0x6 = 64 clock cycles</td> <td>0xE = 544 clock cycles</td> </tr> <tr> <td>0x7 = 80 clock cycles</td> <td>0xF = 800 clock cycles</td> </tr> </table>	0x0 = (Default) 32 clock cycles	0x8 = 96 clock cycles	0x1 = 36 clock cycles	0x9 = 128 clock cycles	0x2 = 40 clock cycles	0xA = 160 clock cycles	0x3 = 44 clock cycles	0xB = 224 clock cycles	0x4 = 48 clock cycles	0xC = 288 clock cycles	0x5 = 56 clock cycles	0xD = 416 clock cycles	0x6 = 64 clock cycles	0xE = 544 clock cycles	0x7 = 80 clock cycles	0xF = 800 clock cycles
0x0 = (Default) 32 clock cycles	0x8 = 96 clock cycles																	
0x1 = 36 clock cycles	0x9 = 128 clock cycles																	
0x2 = 40 clock cycles	0xA = 160 clock cycles																	
0x3 = 44 clock cycles	0xB = 224 clock cycles																	
0x4 = 48 clock cycles	0xC = 288 clock cycles																	
0x5 = 56 clock cycles	0xD = 416 clock cycles																	
0x6 = 64 clock cycles	0xE = 544 clock cycles																	
0x7 = 80 clock cycles	0xF = 800 clock cycles																	
7:4	HGC_CSB_RISE_DLY	<p>Chip Select (CS) rise delay. Configures the minimum time from SCLK active edge to CS rising edge (end of SPI transaction). The delay is defined in system-clock cycles.</p> <p>For 48 kHz-related sample rates, the system-clock period is 1/24.576 MHz. For 44.1 kHz-related sample rates, the system-clock period is 1/22.5792 MHz.</p> <table> <tr> <td>0x0 = (Default) 2 clock cycles</td> <td>0x8 = 18 clock cycles</td> </tr> <tr> <td>0x1 = 4 clock cycles</td> <td>0x9 = 20 clock cycles</td> </tr> <tr> <td>0x2 = 6 clock cycles</td> <td>0xA = 22 clock cycles</td> </tr> <tr> <td>0x3 = 8 clock cycles</td> <td>0xB = 24 clock cycles</td> </tr> <tr> <td>0x4 = 10 clock cycles</td> <td>0xC = 26 clock cycles</td> </tr> <tr> <td>0x5 = 12 clock cycles</td> <td>0xD = 28 clock cycles</td> </tr> <tr> <td>0x6 = 14 clock cycles</td> <td>0xE = 30 clock cycles</td> </tr> <tr> <td>0x7 = 16 clock cycles</td> <td>0xF = 32 clock cycles</td> </tr> </table>	0x0 = (Default) 2 clock cycles	0x8 = 18 clock cycles	0x1 = 4 clock cycles	0x9 = 20 clock cycles	0x2 = 6 clock cycles	0xA = 22 clock cycles	0x3 = 8 clock cycles	0xB = 24 clock cycles	0x4 = 10 clock cycles	0xC = 26 clock cycles	0x5 = 12 clock cycles	0xD = 28 clock cycles	0x6 = 14 clock cycles	0xE = 30 clock cycles	0x7 = 16 clock cycles	0xF = 32 clock cycles
0x0 = (Default) 2 clock cycles	0x8 = 18 clock cycles																	
0x1 = 4 clock cycles	0x9 = 20 clock cycles																	
0x2 = 6 clock cycles	0xA = 22 clock cycles																	
0x3 = 8 clock cycles	0xB = 24 clock cycles																	
0x4 = 10 clock cycles	0xC = 26 clock cycles																	
0x5 = 12 clock cycles	0xD = 28 clock cycles																	
0x6 = 14 clock cycles	0xE = 30 clock cycles																	
0x7 = 16 clock cycles	0xF = 32 clock cycles																	
3:0	HGC_CSB_FALL_DLY	<p>Chip Select (CS) fall delay. Configures the minimum time from SCLK active edge to CS falling edge (end of SPI transaction). The delay is defined in system-clock cycles.</p> <p>For 48 kHz-related sample rates, the system-clock period is 1/24.576 MHz. For 44.1 kHz-related sample rates, the system-clock period is 1/22.5792 MHz.</p> <table> <tr> <td>0x0 = (Default) 2 clock cycles</td> <td>0x8 = 18 clock cycles</td> </tr> <tr> <td>0x1 = 4 clock cycles</td> <td>0x9 = 20 clock cycles</td> </tr> <tr> <td>0x2 = 6 clock cycles</td> <td>0xA = 22 clock cycles</td> </tr> <tr> <td>0x3 = 8 clock cycles</td> <td>0xB = 24 clock cycles</td> </tr> <tr> <td>0x4 = 10 clock cycles</td> <td>0xC = 26 clock cycles</td> </tr> <tr> <td>0x5 = 12 clock cycles</td> <td>0xD = 28 clock cycles</td> </tr> <tr> <td>0x6 = 14 clock cycles</td> <td>0xE = 30 clock cycles</td> </tr> <tr> <td>0x7 = 16 clock cycles</td> <td>0xF = 32 clock cycles</td> </tr> </table>	0x0 = (Default) 2 clock cycles	0x8 = 18 clock cycles	0x1 = 4 clock cycles	0x9 = 20 clock cycles	0x2 = 6 clock cycles	0xA = 22 clock cycles	0x3 = 8 clock cycles	0xB = 24 clock cycles	0x4 = 10 clock cycles	0xC = 26 clock cycles	0x5 = 12 clock cycles	0xD = 28 clock cycles	0x6 = 14 clock cycles	0xE = 30 clock cycles	0x7 = 16 clock cycles	0xF = 32 clock cycles
0x0 = (Default) 2 clock cycles	0x8 = 18 clock cycles																	
0x1 = 4 clock cycles	0x9 = 20 clock cycles																	
0x2 = 6 clock cycles	0xA = 22 clock cycles																	
0x3 = 8 clock cycles	0xB = 24 clock cycles																	
0x4 = 10 clock cycles	0xC = 26 clock cycles																	
0x5 = 12 clock cycles	0xD = 28 clock cycles																	
0x6 = 14 clock cycles	0xE = 30 clock cycles																	
0x7 = 16 clock cycles	0xF = 32 clock cycles																	

**7.5.7 IN\_CFG**
**Address: 0x0000 2100**

RW	15...8	7	6	5	4	3	2	1	0
	—		—	IN_STEP_RAMP_EN		IN_ZC_TIMEOUT			
Default	0x00	0	0	0	0	0	1	1	1

Bits	Name	Description										
15:5	—	Reserved										
4	IN_STEP_RAMP_EN	<p>Step ramp enable. Enables the digital gain to be used to compensate for step changes in the analog gain.</p> <p>0 = (Default) Disabled 1 = Enabled</p>										
3:0	IN_ZC_TIMEOUT	<p>Timeout for zero-cross detection.</p> <table> <tr> <td>0x0 = 0 (OFF)</td> <td>0x6 = 10 ms</td> </tr> <tr> <td>0x1–0x2 = Reserved</td> <td>0x7 = (Default) 20 ms</td> </tr> <tr> <td>0x3 = 1 ms</td> <td>0x8 = 50 ms</td> </tr> <tr> <td>0x4 = 2 ms</td> <td>0x9 = 100 ms</td> </tr> <tr> <td>0x5 = 5 ms</td> <td>0xA–0xF = Reserved</td> </tr> </table>	0x0 = 0 (OFF)	0x6 = 10 ms	0x1–0x2 = Reserved	0x7 = (Default) 20 ms	0x3 = 1 ms	0x8 = 50 ms	0x4 = 2 ms	0x9 = 100 ms	0x5 = 5 ms	0xA–0xF = Reserved
0x0 = 0 (OFF)	0x6 = 10 ms											
0x1–0x2 = Reserved	0x7 = (Default) 20 ms											
0x3 = 1 ms	0x8 = 50 ms											
0x4 = 2 ms	0x9 = 100 ms											
0x5 = 5 ms	0xA–0xF = Reserved											

**7.5.8 IN\_PATH\_DLY\_DIG**

Address: 0x0000 2104

RW	15	14	13	12	11	10	9	8	7	6	5	4	3	2	1	0
	IN_TM_DLY								IN_INT_DIG_GAIN_DLY							
Default	0	0	0	0	0	0	1	1	0	0	0	0	0	1	0	0

Bits	Name	Description
15:8	IN_TM_DLY	Transient masking delay. Configures the delay from the external analog-gain update to the start of the transient-masking period. The delay is defined in audio sample (1/fs) units. 0x00 = 0 samples 0x01 = 1 samples ... 0xFF = 255 samples
7:0	IN_INT_DIG_GAIN_DLY	Digital gain update delay. Configures the delay from the internal analog-gain update to the digital-gain update. The delay is defined in audio sample (1/fs) units. 0x00 = 0 samples 0x01 = 1 samples ... 0xFF = 255 samples

**7.5.9 IN\_PATH\_DLY\_ANA**

Address: 0x0000 2106

RW	15...8	7	6	5	4	3	2	1	0
	IN_INT_ANA_GAIN_DLY								
Default	0x00	0	0	0	0	0	0	0	0

Bits	Name	Description
15:8	—	Reserved
7:0	IN_INT_ANA_GAIN_DLY	Internal analog gain update delay. Configures the delay from the external analog gain update to the internal analog gain update. The delay is defined in system-clock cycles. For 48 kHz-related sample rates, the system-clock period is 1/24.576 MHz. For 44.1 kHz-related sample rates, the system-clock period is 1/22.5792 MHz. 0x00 = (Default) 0 clock cycles 0x01 = 1 clock cycles ... 0xFF = 255 clock cycles

**7.5.10 IN\_TM\_CFG**

Address: 0x0000 2108

RW	15	14	13	12	11	10	9	8	7	6	5	4	3	2	1	0
	IN_TM_HOLD_TIME											IN_TM_EN				
Default	0	0	0	0	0	1	1	1	0	0	0	0	0	0	0	0

Bits	Name	Description
15:8	IN_TM_HOLD_TIME	Transient masking hold time. Configures the duration of the transient masking. The delay is defined in audio sample (1/fs) units. 0x00 = 0 samples 0x01 = 1 samples ... 0xFF = 255 samples
7:1	—	Reserved
0	IN_TM_EN	Transient masking enable. 0 = (Default) Disabled 1 = Enabled

**7.5.11 IN\_TM\_EN**

Address: 0x0000 2110

RW	15	14	13	12	11	10	9	8	7	6	5	4	3	2	1	0
	—				IN_TM_LD_TIME				—				IN2_TM_LD_EN	IN1_TM_LD_EN		
Default	0	0	0	0	1	1	0	0	0	0	0	0	0	0	0	0

Bits	Name	Description
15:13	—	Reserved
12:8	IN_TM_LD_TIME	Transient masking level-detect time constant. The time constant is defined in audio sample (1/fs) units. 0x00–0x09 = Reserved 0x0A = 1024 samples 0x0B = 2048 samples 0x0C = (Default) 4096 samples 0x0D = 8192 samples 0x0E = 16384 samples 0x0F = 32768 samples 0x10 = 65536 samples 0x11–0x1F = Reserved

Bits	Name	Description
7:2	—	Reserved
1	IN2_TM_LD_EN	Input Channel 2 transient masking level-detect enable. 0 = (Default) Disabled 1 = Enabled
0	IN1_TM_LD_EN	Input Channel 1 transient masking level-detect enable. 0 = (Default) Disabled 1 = Enabled

**7.5.12 IN1\_TM\_THR**
**Address: 0x0000 2114**

RW	15...8	7	6	5	4	3	2	1	0
	—		—				IN1_TM_LD_THR		
Default	0x00	0	0	0	0	1	0	0	1

Bits	Name	Description
15:5	—	Reserved
4:0	IN1_TM_LD_THR	Input Channel 1 transient masking level-detect threshold. Transient masking is applied if the signal level is below the threshold. Signal levels listed are the approximate RMS level of a sine wave that would be detected as just above the threshold. 0x00–0x02 = Reserved 0x03 = –2 dBFS ... 0x09 = (Default) –38 dBFS ... 0x13 = –98 dBFS 0x14–0x1F = Reserved

**7.5.13 IN2\_TM\_THR**
**Address: 0x0000 2118**

RW	15...8	7	6	5	4	3	2	1	0
	—		—				IN2_TM_LD_THR		
Default	0x00	0	0	0	0	1	0	0	1

Bits	Name	Description
15:5	—	Reserved
4:0	IN2_TM_LD_THR	Input Channel 2 transient masking level-detect threshold. Transient masking is applied if the signal level is below the threshold. Signal levels listed are the approximate RMS level of a sine wave that would be detected as just above the threshold. 0x00–0x02 = Reserved 0x03 = –2 dBFS ... 0x09 = (Default) –38 dBFS ... 0x13 = –98 dBFS 0x14–0x1F = Reserved

**7.5.14 IN\_PAD\_CFG**
**Address: 0x0000 2140**

RW	15	14	13	12	11	10	9	8	7	6	5	4	3	2	1	0
			—				IN2_PAD_LD_EN	IN1_PAD_LD_EN				—			IN2_PAD_AUTO_EN	IN1_PAD_AUTO_EN
Default	0	0	0	0	0	0	0	0	0	0	0	0	0	0	0	0

Bits	Name	Description
15:10	—	Reserved
9	IN2_PAD_LD_EN	Input Channel 2 PAD level detector (LD) enable. 0 = (Default) Disabled 1 = Enabled
8	IN1_PAD_LD_EN	Input Channel 1 PAD level detector (LD) enable. 0 = (Default) Disabled 1 = Enabled
7:2	—	Reserved

Bits	Name	Description
1	IN2_PAD_AUTO_EN	Input Channel 2 PAD automatic response enable. 0 = (Default) Disabled 1 = Enabled
0	IN1_PAD_AUTO_EN	Input Channel 1 PAD automatic response enable. 0 = (Default) Disabled 1 = Enabled

**7.5.15 IN\_PAD\_SIGNAL**
**Address: 0x0000 2142**

RW	15	14	13	12	11	10	9	8	7	6	5	4	3	2	1	0
	IN_PAD_LD_AVG	—										IN_PAD_LD_TIME				
Default	0	0	0	0	0	0	0	0	0	0	0	0	1	1	0	0

Bits	Name	Description
15	IN_PAD_LD_AVG	Selects averaged or instantaneous input signal for PAD high-level threshold level detection (LD). 0 = (Default) Averaged signal 1 = Instantaneous signal
14:5	—	Reserved
4:0	IN_PAD_LD_TIME	PAD level-detect time constant. The time constant is defined in audio sample (1/fs) units. 0x00–0x09 = Reserved 0x0A = 1024 samples 0x0B = 2048 samples 0x0C = (Default) 4096 samples 0x0D = 8192 samples 0x0E = 16384 samples 0x0F = 32768 samples 0x10 = 65536 samples 0x11–0x1F = Reserved

**7.5.16 IN1\_PAD\_THR**
**Address: 0x0000 2146**

RW	15	14	13	12	11	10	9	8	7	6	5	4	3	2	1	0
	—				IN1_PAD_LOW_THR				—				IN1_PAD_HIGH_THR			
Default	0	0	0	0	1	0	1	0	0	0	0	0	0	1	1	0

Bits	Name	Description
15:12	—	Reserved
11:8	IN1_PAD_LOW_THR	Input Channel 1 PAD level detector (LD) low-level threshold. 0x0–0x2 = Reserved 0x3 = –38.0 dBFS ... 0x9 = –74.0 dBFS 0xA = (Default) –80.0 dBFS 0xB–0xE = Reserved 0xF = mute
7:5	—	Reserved
4:0	IN1_PAD_HIGH_THR	Input Channel 1 PAD level detector (LD) high-level threshold. 0x00 = –1 dBFS 0x01 = –2 dBFS ... 0x06 = (Default) –7 dBFS ... 0x1E = –31 dBFS 0x1F = –32 dBFS

**7.5.17 IN2\_PAD\_THR**
**Address: 0x0000 214A**

RW	15	14	13	12	11	10	9	8	7	6	5	4	3	2	1	0
	—				IN2_PAD_LOW_THR				—				IN2_PAD_HIGH_THR			
Default	0	0	0	0	1	0	1	0	0	0	0	0	0	1	1	0

Bits	Name	Description
15:12	—	Reserved
11:8	IN2_PAD_LOW_THR	Input Channel 2 PAD level detector (LD) low-level threshold. 0x0–0x2 = Reserved 0x3 = –38 dBFS ... 0x9 = –74 dBFS 0xA = (Default) –80 dBFS 0xB–0xE = Reserved 0xF = mute

Bits	Name	Description
7:5	—	Reserved
4:0	IN2_PAD_HIGH_THR	Input Channel 2 PAD level detector (LD) high-level threshold. 0x00 = -1 dBFS 0x01 = -2 dBFS ... 0x1E = -31 dBFS ... 0x1F = -32 dBFS 0x06 = (Default) -7 dBFS

**7.5.18 IN\_SIG\_ACT\_EN**
**Address: 0x0000 2170**

RW	15...8	7	6	5	4	3	2	1	0
	—				—			IN_SIG_ACT_HIGH_EN	IN_SIG_ACT_LOW_EN
Default	0x00	0	0	0	0	0	0	0	0

Bits	Name	Description
15:2	—	Reserved
1	IN_SIG_ACT_HIGH_EN	Signal-activity detection, active-detection enable. 0 = (Default) Disabled 1 = Enabled
0	IN_SIG_ACT_LOW_EN	Signal-activity detection, idle-detection enable. 0 = (Default) Disabled 1 = Enabled

**7.5.19 IN1\_SIG\_ACT\_THR**
**Address: 0x0000 2176**

RW	15	14	13	12	11	10	9	8	7	6	5	4	3	2	1	0
					IN1_SIG_ACT_HIGH_THR								IN1_SIG_ACT_LOW_THR			
Default	0	0	0	0	1	0	1	0	0	0	0	0	0	1	1	1

Bits	Name	Description
15:12	—	Reserved
11:8	IN1_SIG_ACT_HIGH_THR	Input Channel 1 signal-activity detection, high-level threshold. 0x0–0x2 = Reserved 0x3 = -38 dBFS ... 0xA = (Default) -80 dBFS 0xB–0xE = Reserved 0xF = mute
7:4	—	Reserved
3:0	IN1_SIG_ACT_LOW_THR	Input Channel 1 signal-activity detection, low-level threshold. 0x0–0x2 = Reserved 0x3 = -80 dBFS ... 0x7 = (Default) -104 dBFS 0x8–0xE = Reserved 0xF = mute

**7.5.20 IN2\_SIG\_ACT\_THR**
**Address: 0x0000 217A**

RW	15	14	13	12	11	10	9	8	7	6	5	4	3	2	1	0
					IN2_SIG_ACT_HIGH_THR								IN2_SIG_ACT_LOW_THR			
Default	0	0	0	0	1	0	1	0	0	0	0	0	0	1	1	1

Bits	Name	Description
15:12	—	Reserved
11:8	IN2_SIG_ACT_HIGH_THR	Input Channel 2 signal-activity detection high-level threshold. 0x0–0x2 = Reserved 0x3 = -38 dBFS ... 0xA = (Default) -80 dBFS 0xB–0xE = Reserved 0xF = mute
7:4	—	Reserved
3:0	IN2_SIG_ACT_LOW_THR	Input Channel 2 signal-activity detection low-level threshold. 0x0–0x2 = Reserved 0x3 = -80 dBFS ... 0x7 = (Default) -104 dBFS 0x8–0xE = Reserved 0xF = mute

**7.5.21 IN1\_CFG\_SPI**

Address: 0x0000 2200

RW	15	14	13	12	11	10	9	8	7	6	5	4	3	2	1	0
	—				IN1_SPI_POSITION				—		IN1_BIT_PATT_LENGTH					
Default	0	0	0	0	0	0	0	0	0	0	0	0	0	0	0	0

Bits	Name	Description
15:11	—	Reserved
10:8	IN1_SPI_POSITION	Input Channel 1 device position in the SPI chain.
7:6	—	Reserved
5:0	IN1_BIT_PATT_LENGTH	Input Channel 1 bit-pattern length for SPI gain control. 0x00 = (Default) 0 bits (device not present)      ... 0x01 = 1 bits      0x20 = 32 bits 0x02 = 2 bits      0x21–0x3F = Reserved

**7.5.22 IN1\_CFG\_GPIO**

Address: 0x0000 2202

RW	15	14	13	12	11	10	9	8	7	6	5	4	3	2	1	0
	—			IN1_GPI_POL	—	IN1_GPI_SEL			—				IN1_GPO4_SEL	IN1_GPO3_SEL	IN1_GPO2_SEL	IN1_GPO1_SEL
Default	0	0	0	0	0	0	0	0	0	0	0	0	0	0	0	0

Bits	Name	Description
15:13	—	Reserved
12	IN1_GPI_POL	Input Channel 1 GPI polarity. 0 = (Default) GPI not inverted 1 = GPI inverted
11	—	Reserved
10:8	IN1_GPI_SEL	Select GPIO pin as GPI for input Channel 1. 000 = (Default) Select GPI disabled      011 = Select GPIO3 001 = Select GPIO1      100 = Select GPIO4 010 = Select GPIO2      101–111 = Reserved
7:4	—	Reserved
3	IN1_GPO4_SEL	Input Channel 1 GPO4 configuration. 0 = (Default) Disabled 1 = Enabled
2	IN1_GPO3_SEL	Input Channel 1 GPO3 configuration. 0 = (Default) Disabled 1 = Enabled
1	IN1_GPO2_SEL	Input Channel 1 GPO2 configuration. 0 = (Default) Disabled 1 = Enabled
0	IN1_GPO1_SEL	Input Channel 1 GPO1 configuration. 0 = (Default) Disabled 1 = Enabled

**7.5.23 IN2\_CFG\_SPI**

Address: 0x0000 2204

RW	15	14	13	12	11	10	9	8	7	6	5	4	3	2	1	0
	—				IN2_SPI_POSITION				—		IN2_BIT_PATT_LENGTH					
Default	0	0	0	0	0	0	0	0	0	0	0	0	0	0	0	0

Bits	Name	Description
15:11	—	Reserved
10:8	IN2_SPI_POSITION	Input Channel 2 device position in the SPI chain.
7:6	—	Reserved
5:0	IN2_BIT_PATT_LENGTH	Input Channel 2 bit-pattern length for SPI gain control. 0x00 = (Default) 0 bits (device not present)      ... 0x01 = 1 bits      0x20 = 32 bits 0x02 = 2 bits      0x21–0x3F = Reserved

**7.5.24 IN2\_CFG\_GPIO**
**Address: 0x0000 2206**

RW	15	14	13	12	11	10	9	8	7	6	5	4	3	2	1	0
	—			IN2_GPI_POL	—	IN2_GPI_SEL			—				IN2_GPO4_SEL	IN2_GPO3_SEL	IN2_GPO2_SEL	IN2_GPO1_SEL
Default	0	0	0	0	0	0	0	0	0	0	0	0	0	0	0	0

Bits	Name	Description
15:13	—	Reserved
12	IN2_GPI_POL	GPI polarity for input Channel 2. 0 = (Default) GPI not inverted 1 = GPI inverted
11	—	Reserved
10:8	IN2_GPI_SEL	Select GPIO pin as GPI for input Channel 2. 000 = (Default) Select GPI disabled 001 = Select GPIO1 010 = Select GPIO2 011 = Select GPIO3 100 = Select GPIO4 101–111 = Reserved
7:4	—	Reserved
3	IN2_GPO4_SEL	Input Channel 2 GPO4 configuration. 0 = (Default) Disabled 1 = Enabled
2	IN2_GPO3_SEL	Input Channel 2 GPO3 configuration. 0 = (Default) Disabled 1 = Enabled
1	IN2_GPO2_SEL	Input Channel 2 GPO2 configuration. 0 = (Default) Disabled 1 = Enabled
0	IN2_GPO1_SEL	Input Channel 2 GPO1 configuration. 0 = (Default) Disabled 1 = Enabled

**7.5.25 IN1\_BIT\_PATT\_0**
**Address: 0x0000 2220**

RW	15	14	13	12	11	10	9	8	7	6	5	4	3	2	1	0
	IN1_BIT_PATT_0															
Default	0	0	0	0	0	0	0	0	0	0	0	0	0	0	0	0

Bits	Name	Description
15:0	IN1_BIT_PATT_0	Input Channel 1 SPI bit pattern for external gain control, bits 1-16. The contents of the bit pattern must be left-aligned such that the first bit for transmission is in the MSB. If the bit pattern is shorter than 32 bits, one or more of the LSBs is unused.

**7.5.26 IN1\_BIT\_PATT\_1**
**Address: 0x0000 2222**

RW	15	14	13	12	11	10	9	8	7	6	5	4	3	2	1	0
	IN1_BIT_PATT_1															
Default	0	0	0	0	0	0	0	0	0	0	0	0	0	0	0	0

Bits	Name	Description
15:0	IN1_BIT_PATT_1	Input Channel 1 SPI bit pattern for external gain control, bits 17-32. Only used if the bit pattern is longer than 16 bits. The contents of the bit pattern must be left-aligned such that the first bit for transmission is in the MSB. If the bit pattern is shorter than 32 bits, one or more of the LSBs is unused. If the external gain is controlled using GPIOs, the GPIO1-4 output logic levels are determined by bits 12–15 respectfully.

**7.5.27 IN1\_EXT\_GAIN**

Address: 0x0000 2224

RW	15	14	13	12	11	10	9	8	7	6	5	4	3	2	1	0
	—				IN1_EXT_ANA_GAIN											
Default	0	0	0	0	0	0	0	0	0	0	0	0	0	0	0	0

Bits	Name	Description
15:11	—	Reserved
10:0	IN1_EXT_ANA_GAIN	Input Channel 1 external analog gain. The selected value must match the external analog gain of the associated SPI bit pattern. 0x000 = (Default) 0.000 dB 0x001 = 0.125 dB 0x002 = 0.250 dB ... 0x23F = 71.875 dB 0x240–0x5BF = Reserved 0x5C0 = –72.000 dB ... 0x7FF = –0.125 dB

**7.5.28 IN1\_INT\_GAIN**

Address: 0x0000 2226

	15	14	13	12	11	10	9	8	7	6	5	4	3	2	1	0
	IN1_UPDATE	—	IN1_INT_ANA_GAIN		—		IN1_INT_DIG_GAIN									
Access	WO	—	RW		—		RW									
Default	0	0	0	0	0	0	0	0	0	0	0	0	0	0	0	0

Bits	Name	Description
15	IN1_UPDATE	Input Channel 1 gain update. Write 1 to apply the Channel 1 gain selection and SPI bit pattern. The gain update is applied at the next scheduling opportunity, zero-cross aligned.
14	—	Reserved
13:12	IN1_INT_ANA_GAIN	Input Channel 1 internal analog gain. 00 = (Default) 0 dB 01 = 6 dB 10 = Reserved 11 = 12 dB
11:9	—	Reserved
8:0	IN1_INT_DIG_GAIN	Input Channel 1 digital gain. Note the signal level is also controlled by the digital volume. 0x000 = (Default) 0.000 dB 0x001 = 0.125 dB ... 0x0FF = 31.875 dB 0x100 = –32.000 dB ... 0x1FF = –0.125 dB

**7.5.29 IN2\_BIT\_PATT\_0**

Address: 0x0000 2228

RW	15	14	13	12	11	10	9	8	7	6	5	4	3	2	1	0
	IN2_BIT_PATT_0															
Default	0	0	0	0	0	0	0	0	0	0	0	0	0	0	0	0

Bits	Name	Description
15:0	IN2_BIT_PATT_0	Input Channel 2 SPI bit pattern for external gain control, bits 1-16. The contents of the bit pattern must be left-aligned such that the first bit for transmission is in the MSB. If the bit pattern is shorter than 32 bits, one or more of the LSBs is unused.

**7.5.30 IN2\_BIT\_PATT\_1**

Address: 0x0000 222A

RW	15	14	13	12	11	10	9	8	7	6	5	4	3	2	1	0
	IN2_BIT_PATT_1															
Default	0	0	0	0	0	0	0	0	0	0	0	0	0	0	0	0

Bits	Name	Description
15:0	IN2_BIT_PATT_1	Input Channel 2 SPI bit pattern for external gain control, bits 17-32. Only used if the bit pattern is longer than 16 bits. The contents of the bit pattern must be left-aligned such that the first bit for transmission is in the MSB. If the bit pattern is shorter than 32 bits, one or more of the LSBs is unused. If the external gain is controlled using GPIOs, the GPIO1-4 output logic levels are determined by bits 12–15 respectfully.

**7.5.31 IN2\_EXT\_GAIN**
**Address: 0x0000 222C**

RW	15	14	13	12	11	10	9	8	7	6	5	4	3	2	1	0
	—				IN2_EXT_ANA_GAIN											
Default	0	0	0	0	0	0	0	0	0	0	0	0	0	0	0	0

Bits	Name	Description
15:11	—	Reserved
10:0	IN2_EXT_ANA_GAIN	Input Channel 2 external analog gain. The selected value must match the external analog gain of the associated SPI bit pattern. 0x000 = (Default) 0.000 dB 0x001 = 0.125 dB ... 0x23F = 71.875 dB 0x240–0x5BF = Reserved 0x5C0 = –72.000 dB ... 0x7FF = –0.125 dB

**7.5.32 IN2\_INT\_GAIN**
**Address: 0x0000 222E**

	15	14	13	12	11	10	9	8	7	6	5	4	3	2	1	0
	IN2_UPDATE	—	IN2_INT_ANA_GAIN	—	IN2_INT_DIG_GAIN											
Access	WO	—	RW	—	RW											
Default	0	0	0	0	0	0	0	0	0	0	0	0	0	0	0	0

Bits	Name	Description
15	IN2_UPDATE	Input Channel 2 gain update. Write 1 to apply the Channel 2 gain selection and SPI bit pattern. The gain update is applied at the next scheduling opportunity, zero-cross aligned.
14	—	Reserved
13:12	IN2_INT_ANA_GAIN	Input Channel 2 internal analog gain. 00 = (Default) 0 dB 01 = 6 dB 10 = Reserved 11 = 12 dB
11:9	—	Reserved
8:0	IN2_INT_DIG_GAIN	Input Channel 2 digital gain. Note that the signal level is also controlled by the digital volume. 0x000 = (Default) 0.000 dB 0x001 = 0.125 dB ... 0x0FF = 31.875 dB 0x100 = –32.000 dB ... 0x1FF = –0.125 dB

**7.5.33 IN1\_LOW\_BIT\_PATT\_0**
**Address: 0x0000 2260**

RW	15	14	13	12	11	10	9	8	7	6	5	4	3	2	1	0
	IN1_LOW_BIT_PATT_0															
Default	0	0	0	0	0	0	0	0	0	0	0	0	0	0	0	0

Bits	Name	Description
15:0	IN1_LOW_BIT_PATT_0	Input Channel 1 SPI bit pattern for external gain control, low gain setting for PAD on, bits 1-16. The contents of the bit pattern must be left-aligned such that the first bit for transmission is in the MSB. If the bit pattern is shorter than 32 bits, one or more of the LSBs is unused.

**7.5.34 IN1\_LOW\_BIT\_PATT\_1**
**Address: 0x0000 2262**

RW	15	14	13	12	11	10	9	8	7	6	5	4	3	2	1	0
	IN1_LOW_BIT_PATT_1															
Default	0	0	0	0	0	0	0	0	0	0	0	0	0	0	0	0

Bits	Name	Description
15:0	IN1_LOW_BIT_PATT_1	Input Channel 1 SPI bit pattern for external gain control, bits 17-32. Only used if the bit pattern is longer than 16 bits. The contents of the bit pattern must be left-aligned such that the first bit for transmission is in the MSB. If the bit pattern is shorter than 32 bits, one or more of the LSBs is unused. If the external gain is controlled using GPIOs, the GPIO1-4 output logic levels are determined by bits 12–15 respectfully.

**7.5.35 IN1\_LOW\_EXT\_GAIN**
**Address: 0x0000 2264**

RW	15	14	13	12	11	10	9	8	7	6	5	4	3	2	1	0
	—				IN1_LOW_EXT_ANA_GAIN											
Default	0	0	0	0	0	0	0	0	0	0	0	0	0	0	0	0

Bits	Name	Description
15:11	—	Reserved
10:0	IN1_LOW_EXT_ANA_GAIN	Input Channel 1 external analog gain. The selected value must match the analog gain of the associated SPI bit pattern. 0x000 = (Default) 0.000 dB 0x001 = 0.125 dB ... 0x23F = 71.875 dB 0x240–0x5BF = Reserved 0x5C0 = –72.000 dB ... 0x7FF = –0.125 dB

**7.5.36 IN1\_LOW\_INT\_GAIN**
**Address: 0x0000 2266**

	15	14	13	12	11	10	9	8	7	6	5	4	3	2	1	0
	IN1_LOW_UPDATE	—	IN1_LOW_INT_ANA_GAIN	—	—	IN1_LOW_INT_DIG_GAIN										
Access	WO	—	RW	—	—	RW										
Default	0	0	0	0	0	0	0	0	0	0	0	0	0	0	0	0

Bits	Name	Description
15	IN1_LOW_UPDATE	Input Channel 1 gain update. Write 1 to apply the Channel 1 gain selection and SPI bit pattern. The gain update is applied at the next scheduling opportunity, zero-cross aligned.
14	—	Reserved
13:12	IN1_LOW_INT_ANA_GAIN	Input Channel 1 internal analog gain. 00 = (Default) 0 dB 01 = 6 dB 10 = Reserved 11 = 12 dB
11:9	—	Reserved
8:0	IN1_LOW_INT_DIG_GAIN	Input Channel 1 digital gain. 0x000 = (Default) 0.000 dB 0x001 = 0.125 dB ... 0x0FF = 31.875 dB 0x100 = –32.000 dB ... 0x1FF = –0.125 dB

**7.5.37 IN2\_LOW\_BIT\_PATT\_0**
**Address: 0x0000 2268**

RW	15	14	13	12	11	10	9	8	7	6	5	4	3	2	1	0
	IN2_LOW_BIT_PATT_0															
Default	0	0	0	0	0	0	0	0	0	0	0	0	0	0	0	0

Bits	Name	Description
15:0	IN2_LOW_BIT_PATT_0	Input Channel 2 SPI bit pattern for external gain control, low gain setting for PAD on, bits 1-16. The contents of the bit pattern must be left-aligned such that the first bit for transmission is in the MSB. If the bit pattern is shorter than 32 bits, one or more of the LSBs is unused.

**7.5.38 IN2\_LOW\_BIT\_PATT\_1**
**Address: 0x0000 226A**

RW	15	14	13	12	11	10	9	8	7	6	5	4	3	2	1	0
	IN2_LOW_BIT_PATT_1															
Default	0	0	0	0	0	0	0	0	0	0	0	0	0	0	0	0

Bits	Name	Description
15:0	IN2_LOW_BIT_PATT_1	Input Channel 2 SPI bit pattern for external gain control, bits 17-32. Only used if the bit pattern is longer than 16 bits. The contents of the bit pattern must be left-aligned such that the first bit for transmission is in the MSB. If the bit pattern is shorter than 32 bits, one or more of the LSBs is unused. If the external gain is controlled using GPIOs, the GPIO1-4 output logic levels are determined by bits 12–15 respectfully.

**7.5.39 IN2\_LOW\_EXT\_GAIN**

Address: 0x0000 226C

RW	15	14	13	12	11	10	9	8	7	6	5	4	3	2	1	0
	—				IN2_LOW_EXT_ANA_GAIN											
Default	0	0	0	0	0	0	0	0	0	0	0	0	0	0	0	0

Bits	Name	Description
15:11	—	Reserved
10:0	IN2_LOW_EXT_ANA_GAIN	Input Channel 2 external analog gain. The selected value must match the analog gain of the associated SPI bit pattern. 0x000 = (Default) 0.000 dB 0x001 = 0.125 dB ... 0x23F = 71.875 dB 0x240–0x5BF = Reserved 0x5C0 = –72.000 dB ... 0x7FF = –0.125 dB

**7.5.40 IN2\_LOW\_INT\_GAIN**

Address: 0x0000 226E

	15	14	13	12	11	10	9	8	7	6	5	4	3	2	1	0
	IN2_LOW_UPDATE	—	IN2_LOW_INT_ANA_GAIN	—	—	IN2_LOW_INT_DIG_GAIN										
Access	WO	—	RW	—	—	RW										
Default	0	0	0	0	0	0	0	0	0	0	0	0	0	0	0	0

Bits	Name	Description
15	IN2_LOW_UPDATE	Input Channel 2 gain update. Write 1 to apply Channel 2 gain selection and SPI bit pattern. The gain update is applied at the next scheduling opportunity, zero-cross aligned.
14	—	Reserved
13:12	IN2_LOW_INT_ANA_GAIN	Input Channel 2 internal analog gain. 00 = (Default) 0 dB 01 = 6 dB 10 = Reserved 11 = 12 dB
11:9	—	Reserved
8:0	IN2_LOW_INT_DIG_GAIN	Input Channel 2 digital gain. 0x000 = (Default) 0.000 dB 0x001 = 0.125 dB ... 0x0FF = 31.875 dB 0x100 = –32.000 dB ... 0x1FF = –0.125 dB

**7.5.41 IN1\_HIGH\_BIT\_PATT\_0**

Address: 0x0000 22C0

RW	15	14	13	12	11	10	9	8	7	6	5	4	3	2	1	0
	IN1_HIGH_BIT_PATT_0															
Default	0	0	0	0	0	0	0	0	0	0	0	0	0	0	0	0

Bits	Name	Description
15:0	IN1_HIGH_BIT_PATT_0	Input Channel 1 SPI bit pattern for external gain control, high gain setting for PAD off, bits 1-16. The contents of the bit pattern must be left-aligned such that the first bit for transmission is in the MSB. If the bit pattern is shorter than 32 bits, one or more of the LSBs is unused.

**7.5.42 IN1\_HIGH\_BIT\_PATT\_1**

Address: 0x0000 22C2

RW	15	14	13	12	11	10	9	8	7	6	5	4	3	2	1	0
	IN1_HIGH_BIT_PATT_1															
Default	0	0	0	0	0	0	0	0	0	0	0	0	0	0	0	0

Bits	Name	Description
15:0	IN1_HIGH_BIT_PATT_1	Input Channel 2 SPI bit pattern for external gain control, bits 17-32. Only used if the bit pattern is longer than 16 bits. The contents of the bit pattern must be left-aligned such that the first bit for transmission is in the MSB. If the bit pattern is shorter than 32 bits, one or more of the LSBs is unused. If the external gain is controlled using GPIOs, the GPIO1-4 output logic levels are determined by bits 12–15 respectfully.

**7.5.43 IN1\_HIGH\_EXT\_GAIN**

Address: 0x0000 22C4

RW	15	14	13	12	11	10	9	8	7	6	5	4	3	2	1	0
	—				IN1_HIGH_EXT_ANA_GAIN											
Default	0	0	0	0	0	0	0	0	0	0	0	0	0	0	0	0

Bits	Name	Description
15:11	—	Reserved
10:0	IN1_HIGH_EXT_ANA_GAIN	Input Channel 1 external analog gain. The selected value must match the analog gain of the associated SPI bit pattern. 0x000 = (Default) 0.000 dB 0x001 = 0.125 dB 0x002 = 0.250 dB ... 0x23F = 71.875 dB 0x240–0x5BF = Reserved 0x5C0 = –72.000 dB ... 0x7FF = –0.125 dB

**7.5.44 IN1\_HIGH\_INT\_GAIN**

Address: 0x0000 22C6

	15	14	13	12	11	10	9	8	7	6	5	4	3	2	1	0
	IN1_HIGH_UPDATE	—	IN1_HIGH_INT_ANA_GAIN	—	IN1_HIGH_INT_DIG_GAIN											
Access	WO	—	RW	—	RW											
Default	0	0	0	0	0	0	0	0	0	0	0	0	0	0	0	0

Bits	Name	Description
15	IN1_HIGH_UPDATE	Input Channel 1 gain update. Write 1 to apply the Channel 1 gain selection and SPI bit pattern. The gain update is applied at the next scheduling opportunity, zero-cross aligned.
14	—	Reserved
13:12	IN1_HIGH_INT_ANA_GAIN	Input Channel 1 internal analog gain. 00 = (Default) 0 dB 01 = 6 dB 10 = Reserved 11 = 12 dB
11:9	—	Reserved
8:0	IN1_HIGH_INT_DIG_GAIN	Input Channel 1 digital gain. 0x000 = (Default) 0.000 dB 0x001 = 0.125 dB ... 0x0FF = 31.875 dB 0x100 = –32.000 dB ... 0x1FF = –0.125 dB

**7.5.45 IN2\_HIGH\_BIT\_PATT\_0**

Address: 0x0000 22C8

RW	15	14	13	12	11	10	9	8	7	6	5	4	3	2	1	0
	IN2_HIGH_BIT_PATT_0															
Default	0	0	0	0	0	0	0	0	0	0	0	0	0	0	0	0

Bits	Name	Description
15:0	IN2_HIGH_BIT_PATT_0	Input Channel 2 SPI bit pattern for external gain control, high gain setting for PAD off, bits 1-16. The contents of the bit pattern must be left-aligned such that the first bit for transmission is in the MSB. If the bit pattern is shorter than 32 bits, one or more of the LSBs is unused.

**7.5.46 IN2\_HIGH\_BIT\_PATT\_1**

Address: 0x0000 22CA

RW	15	14	13	12	11	10	9	8	7	6	5	4	3	2	1	0
	IN2_HIGH_BIT_PATT_1															
Default	0	0	0	0	0	0	0	0	0	0	0	0	0	0	0	0

Bits	Name	Description
15:0	IN2_HIGH_BIT_PATT_1	Input Channel 2 SPI bit pattern for external gain control, bits 17-32. Only used if the bit pattern is longer than 16 bits. The contents of the bit pattern must be left-aligned such that the first bit for transmission is in the MSB. If the bit pattern is shorter than 32 bits, one or more of the LSBs is unused. If the external gain is controlled using GPIOs, the GPIO1-4 output logic levels are determined by bits 12–15 respectfully.

**7.5.47 IN2\_HIGH\_EXT\_GAIN**

Address: 0x0000 22CC

RW	15	14	13	12	11	10	9	8	7	6	5	4	3	2	1	0
	—				IN2_HIGH_EXT_ANA_GAIN											
Default	0	0	0	0	0	0	0	0	0	0	0	0	0	0	0	0

Bits	Name	Description
15:11	—	Reserved
10:0	IN2_HIGH_EXT_ANA_GAIN	Input Channel 2 external analog gain. The selected value must match the analog gain of the associated SPI bit pattern. 0x000 = (Default) 0.000 dB 0x001 = 0.125 dB ... 0x23F = 71.875 dB
		0x240–0x5BF = Reserved 0x5C0 = –72.000 dB ... 0x7FF = –0.125 dB

**7.5.48 IN2\_HIGH\_INT\_GAIN**

Address: 0x0000 22CE

	15	14	13	12	11	10	9	8	7	6	5	4	3	2	1	0
	IN2_HIGH_UPDATE	—	IN2_HIGH_INT_ANA_GAIN	—	—	IN2_HIGH_INT_DIG_GAIN										
Access	WO	—	RW	—	—	RW										
Default	0	0	0	0	0	0	0	0	0	0	0	0	0	0	0	

Bits	Name	Description
15	IN2_HIGH_UPDATE	Input Channel 2 gain update. Write 1 to apply the Channel 2 gain selection and SPI bit pattern. The gain update is applied at the next scheduling opportunity, zero-cross aligned.
14	—	Reserved
13:12	IN2_HIGH_INT_ANA_GAIN	Input Channel 2 internal analog gain. 00 = (Default) 0 dB 01 = 6 dB 10 = Reserved 11 = 12 dB
11:9	—	Reserved
8:0	IN2_HIGH_INT_DIG_GAIN	Input Channel 2 digital gain. 0x000 = (Default) 0.000 dB 0x001 = 0.125 dB ... 0x0FF = 31.875 dB 0x100 = –32.000 dB ... 0x1FF = –0.125 dB

**7.5.49 OUT\_CFG**

Address: 0x0000 2500

RW	15...8	7	6	5	4	3	2	1	0	
	—	—	—	—	OUT_STEP_RAMP_EN	OUT_ZC_TIMEOUT				
Default	0x00	0	0	0	0	0	1	1	1	

Bits	Name	Description
15:5	—	Reserved
4	OUT_STEP_RAMP_EN	Step ramp enable. Enables the digital gain to be used to compensate for step changes in the analog gain. 0 = (Default) Disabled 1 = Enabled
3:0	OUT_ZC_TIMEOUT	Timeout for zero-cross detection. 0x0 = 0 (OFF) 0x1–0x2 = Reserved 0x3 = 1 ms 0x4 = 2 ms 0x5 = 5 ms 0x6 = 10 ms 0x7 = (Default) 20 ms 0x8–0xF = Reserved

**7.5.50 OUT\_PATH\_EXT\_DLY**
**Address: 0x0000 2504**

RW	15	14	13	12	11	10	9	8	7	6	5	4	3	2	1	0
	—				OUT_EXT_GAIN_DLY											
Default	0	0	0	0	0	0	0	0	0	1	1	0	1	0	0	1

Bits	Name	Description
15:12	—	Reserved
11:0	OUT_EXT_GAIN_DLY	Wait for signal processing (SP) through interpolation to apply external gain changes. 0x000 = 0 1/24MHz 0x001 = 1 1/24MHz ... 0x0FF = 255 1/24MHz ... 0x069 = (Default) 105 1/24MHz 0x100–0xFF = Reserved

**7.5.51 OUT1\_CFG\_SPI**
**Address: 0x0000 2600**

RW	15	14	13	12	11	10	9	8	7	6	5	4	3	2	1	0
	—				OUT1_SPI_POSITION				—		OUT1_BIT_PATT_LENGTH					
Default	0	0	0	0	0	0	0	0	0	0	0	0	0	0	0	0

Bits	Name	Description
15:11	—	Reserved
10:8	OUT1_SPI_POSITION	Output Channel 1 device position in the SPI chain.
7:6	—	Reserved
5:0	OUT1_BIT_PATT_LENGTH	Output Channel 1 bit-pattern length for SPI gain control. 0x00 = (Default) 0 bits (device not present) 0x01 = 1 bits 0x02 = 2 bits ... 0x20 = 32 bits 0x21–0x3F = Reserved

**7.5.52 OUT1\_CFG\_GPIO**
**Address: 0x0000 2602**

RW	15	14	13	12	11	10	9	8	7	6	5	4	3	2	1	0
	—			OUT1_GPI_POL	—								OUT1_GPO4_SEL	OUT1_GPO3_SEL	OUT1_GPO2_SEL	OUT1_GPO1_SEL
Default	0	0	0	0	0	0	0	0	0	0	0	0	0	0	0	0

Bits	Name	Description
15:13	—	Reserved
12	OUT1_GPI_POL	GPI polarity for output Channel 1. 0 = (Default) GPI not inverted 1 = GPI inverted
11:4	—	Reserved
3	OUT1_GPO4_SEL	Select GPIO4 pin as GPO for output Channel 1. 0 = (Default) Disabled 1 = Enabled
2	OUT1_GPO3_SEL	Select GPIO3 pin as GPO for output Channel 1. 0 = (Default) Disabled 1 = Enabled
1	OUT1_GPO2_SEL	Select GPIO2 pin as GPO for output Channel 1. 0 = (Default) Disabled 1 = Enabled
0	OUT1_GPO1_SEL	Select GPIO1 pin as GPO for output Channel 1. 0 = (Default) Disabled 1 = Enabled

**7.5.53 OUT2\_CFG\_SPI**

Address: 0x0000 2604

RW	15	14	13	12	11	10	9	8	7	6	5	4	3	2	1	0
	—				OUT2_SPL_POSITION				—		OUT2_BIT_PATT_LENGTH					
Default	0	0	0	0	0	0	0	0	0	0	0	0	0	0	0	0

Bits	Name	Description
15:11	—	Reserved
10:8	OUT2_SPI_POSITION	Output Channel 2 device position in the SPI chain.
7:6	—	Reserved
5:0	OUT2_BIT_PATT_LENGTH	Output Channel 2 bit-pattern length for SPI gain control. 0x00 = (Default) 0 bits (device not present) 0x01 = 1 bits 0x02 = 2 bits ... 0x20 = 32 bits 0x21–0x3F = Reserved

**7.5.54 OUT2\_CFG\_GPIO**

Address: 0x0000 2606

RW	15	14	13	12	11	10	9	8	7	6	5	4	3	2	1	0
	—			OUT2_GPI_POL	—								OUT2_GPO4_SEL	OUT2_GPO3_SEL	OUT2_GPO2_SEL	OUT2_GPO1_SEL
Default	0	0	0	0	0	0	0	0	0	0	0	0	0	0	0	0

Bits	Name	Description
15:13	—	Reserved
12	OUT2_GPI_POL	GPI polarity for output Channel 2. 0 = (Default) GPI not inverted 1 = GPI inverted
11:4	—	Reserved
3	OUT2_GPO4_SEL	Select GPIO4 pin as GPO for output Channel 2. 0 = (Default) Disabled 1 = Enabled
2	OUT2_GPO3_SEL	Select GPIO3 pin as GPO for output Channel 2. 0 = (Default) Disabled 1 = Enabled
1	OUT2_GPO2_SEL	Select GPIO2 pin as GPO for output Channel 2. 0 = (Default) Disabled 1 = Enabled
0	OUT2_GPO1_SEL	Select GPIO1 pin as GPO for output Channel 2. 0 = (Default) Disabled 1 = Enabled

**7.5.55 OUT1\_BIT\_PATT\_0**

Address: 0x0000 2620

RW	15	14	13	12	11	10	9	8	7	6	5	4	3	2	1	0
	OUT1_BIT_PATT_0															
Default	0	0	0	0	0	0	0	0	0	0	0	0	0	0	0	0

Bits	Name	Description
15:0	OUT1_BIT_PATT_0	Output Channel 1 SPI bit pattern for external gain control, bits 1-16. The contents of the bit pattern must be left-aligned such that the first bit for transmission is in the MSB. If the bit pattern is shorter than 32 bits, one or more of the LSBs is unused.

**7.5.56 OUT1\_BIT\_PATT\_1**
**Address: 0x0000 2622**

RW	15	14	13	12	11	10	9	8	7	6	5	4	3	2	1	0
	OUT1_BIT_PATT_1															
Default	0	0	0	0	0	0	0	0	0	0	0	0	0	0	0	0

Bits	Name	Description
15:0	OUT1_BIT_PATT_1	Output Channel 1 SPI bit pattern for external gain control, bits 17-32. Only used if the bit pattern is longer than 16 bits. The contents of the bit pattern must be left-aligned such that the first bit for transmission is in the MSB. If the bit pattern is shorter than 32 bits, one or more of the LSBs is unused. If the external gain is controlled using GPIOs, the GPIO1-4 output logic levels are determined by bits 12–15 respectfully.

**7.5.57 OUT1\_VOL\_ANA**
**Address: 0x0000 2624**

RW	15	14	13	12	11	10	9	8	7	6	5	4	3	2	1	0
	—				OUT1_ANA_GAIN											
Default	0	0	0	0	0	0	0	0	0	0	0	0	0	0	0	0

Bits	Name	Description
15:11	—	Reserved
10:0	OUT1_ANA_GAIN	Output Channel 1 analog gain. The selected value must match the analog gain of the associated SPI bit pattern. 0x000 = (Default) 0.000 dB 0x001 = 0.125 dB 0x002 = 0.250 dB ... 0x23F = 71.875 dB 0x240–0x5BF = Reserved 0x5C0 = –72.000 dB ... 0x7FF = –0.125 dB

**7.5.58 OUT1\_VOL\_DIG**
**Address: 0x0000 2626**

	15	14	13	12	11	10	9	8	7	6	5	4	3	2	1	0
	OUT1_UPDATE	—							OUT1_DIG_GAIN							
Access	WO	—							RW							
Default	0	0	0	0	0	0	0	0	0	0	0	0	0	0	0	0

Bits	Name	Description
15	OUT1_UPDATE	Output Channel 1 gain update. Write 1 to apply the Channel 1 gain selection and SPI bit pattern. The gain update is applied at the next scheduling opportunity, zero-cross aligned.
14:9	—	Reserved
8:0	OUT1_DIG_GAIN	Output Channel 1 digital gain. Note that the signal level is also controlled by the digital volume (OUTx_VOL). 0x000 = (Default) 0.000 dB 0x001 = 0.125 dB 0x002 = 0.250 dB ... 0x05F = 11.875 dB 0x060–0x09F = Reserved 0x0A0 = –12.000 dB ... 0x0FF = –0.125 dB 0x100–0x1FF = Reserved

**7.5.59 OUT2\_BIT\_PATT\_0**
**Address: 0x0000 2628**

RW	15	14	13	12	11	10	9	8	7	6	5	4	3	2	1	0
	OUT2_BIT_PATT_0															
Default	0	0	0	0	0	0	0	0	0	0	0	0	0	0	0	0

Bits	Name	Description
15:0	OUT2_BIT_PATT_0	Output Channel 2 SPI bit pattern for external gain control, bits 1-16. The contents of the bit pattern must be left-aligned such that the first bit for transmission is in the MSB. If the bit pattern is shorter than 32 bits, one or more of the LSBs is unused. If the external gain is controlled using GPIOs are used, the GPIO1-4 output logic levels are determined by bits 12–15 respectfully.

**7.5.60 OUT2\_BIT\_PATT\_1**

Address: 0x0000 262A

RW	15	14	13	12	11	10	9	8	7	6	5	4	3	2	1	0
	OUT2_BIT_PATT_1															
Default	0	0	0	0	0	0	0	0	0	0	0	0	0	0	0	0

Bits	Name	Description
15:0	OUT2_BIT_PATT_1	Output Channel 1 SPI bit pattern for external gain control, bits 17-32. Only used if the bit pattern is longer than 16 bits. The contents of the bit pattern must be left-aligned such that the first bit for transmission is in the MSB. If the bit pattern is shorter than 32 bits, one or more of the LSBs is unused. If the external gain is controlled using GPIOs, the GPIO1-4 output logic levels are determined by bits 12–15 respectfully.

**7.5.61 OUT2\_VOL\_ANA**

Address: 0x0000 262C

RW	15	14	13	12	11	10	9	8	7	6	5	4	3	2	1	0
	—				OUT2_ANA_GAIN											
Default	0	0	0	0	0	0	0	0	0	0	0	0	0	0	0	0

Bits	Name	Description
15:11	—	Reserved
10:0	OUT2_ANA_GAIN	Output Channel 2 analog gain. The selected value must match the analog gain of the associated SPI bit pattern. 0x000 = (Default) 0.000 dB 0x001 = 0.125 dB 0x002 = 0.250 dB ... 0x23F = 71.875 dB 0x240–0x5BF = Reserved 0x5C0 = –72.000 dB ... 0x7FF = –0.125 dB

**7.5.62 OUT2\_VOL\_DIG**

Address: 0x0000 262E

	15	14	13	12	11	10	9	8	7	6	5	4	3	2	1	0	
	OUT2_UPDATE	—							OUT2_DIG_GAIN								
Access	WO	—							RW								
Default	0	0	0	0	0	0	0	0	0	0	0	0	0	0	0	0	

Bits	Name	Description
15	OUT2_UPDATE	Output Channel 2 gain update. Write 1 to apply the Channel 2 gain selection and SPI bit pattern. The gain update is applied at the next scheduling opportunity, zero-cross aligned.
14:9	—	Reserved
8:0	OUT2_DIG_GAIN	Output Channel 2 digital gain. Note that the signal level is also controlled by the digital volume (OUTx_VOL). 0x000 = (Default) 0.000 dB 0x001 = 0.125 dB 0x002 = 0.250 dB ... 0x05F = 11.875 dB 0x060–0x09F = Reserved 0x0A0 = –12.000 dB ... 0x0FF = –0.125 dB 0x100–0x1FF = Reserved

**7.5.63 AUX1\_CFG**

Address: 0x0000 2900

RW	15	14	13	12	11	10	9	8	7	6	5	4	3	2	1	0
	—				AUX1_SPI_POSITION				—		AUX1_BIT_PATT_LENGTH					
Default	0	0	0	0	0	0	0	0	0	0	0	0	0	0	0	0

Bits	Name	Description
15:11	—	Reserved
10:8	AUX1_SPI_POSITION	AUX Device 1 position in the SPI chain.
7:6	—	Reserved
5:0	AUX1_BIT_PATT_LENGTH	AUX Device 1 bit-pattern length for SPI AUX control. 0x00 = (Default) 0 bits (device not present) 0x01 = 1 bits 0x02 = 2 bits ... 0x20 = 32 bits 0x21–0x3F = Reserved

**7.5.64 AUX2\_CFG**

Address: 0x0000 2904

RW	15	14	13	12	11	10	9	8	7	6	5	4	3	2	1	0
	—				AUX2_SPI_POSITION				—		AUX2_BIT_PATT_LENGTH					
Default	0	0	0	0	0	0	0	0	0	0	0	0	0	0	0	0

Bits	Name	Description
15:11	—	Reserved
10:8	AUX2_SPI_POSITION	AUX Device 2 position in the SPI chain.
7:6	—	Reserved
5:0	AUX2_BIT_PATT_LENGTH	AUX Device 2 bit-pattern length for SPI AUX control. 0x00 = (Default) 0 bits (device not present) 0x01 = 1 bits 0x02 = 2 bits ... 0x20 = 32 bits 0x21–0x3F = Reserved

**7.5.65 AUX1\_BIT\_PATT\_0**

Address: 0x0000 2920

RW	15	14	13	12	11	10	9	8	7	6	5	4	3	2	1	0
	AUX1_BIT_PATT_0															
Default	0	0	0	0	0	0	0	0	0	0	0	0	0	0	0	0

Bits	Name	Description
15:0	AUX1_BIT_PATT_0	AUX Device 1 SPI bit pattern, bits 1-16. The contents of the bit pattern must be left-aligned such that the first bit for transmission is in the MSB. If the bit pattern is shorter than 32 bits, one or more of the LSBs is unused.

**7.5.66 AUX1\_BIT\_PATT\_1**

Address: 0x0000 2922

RW	15	14	13	12	11	10	9	8	7	6	5	4	3	2	1	0
	AUX1_BIT_PATT_1															
Default	0	0	0	0	0	0	0	0	0	0	0	0	0	0	0	0

Bits	Name	Description
15:0	AUX1_BIT_PATT_1	AUX Device 1 SPI bit pattern, bits 17-32. Only used if the bit pattern is longer than 16 bits. The contents of the bit pattern must be left-aligned such that the first bit for transmission is in the MSB. If the bit pattern is shorter than 32 bits, one or more of the LSBs is unused.

**7.5.67 AUX2\_BIT\_PATT\_0**

Address: 0x0000 2924

RW	15	14	13	12	11	10	9	8	7	6	5	4	3	2	1	0
	AUX2_BIT_PATT_0															
Default	0	0	0	0	0	0	0	0	0	0	0	0	0	0	0	0

Bits	Name	Description
15:0	AUX2_BIT_PATT_0	AUX Device 2 SPI bit pattern, bits 1-16. The contents of the bit pattern must be left-aligned such that the first bit for transmission is in the MSB. If the bit pattern is shorter than 32 bits, one or more of the LSBs is unused.

**7.5.68 AUX2\_BIT\_PATT\_1**

Address: 0x0000 2926

RW	15	14	13	12	11	10	9	8	7	6	5	4	3	2	1	0
	AUX2_BIT_PATT_1															
Default	0	0	0	0	0	0	0	0	0	0	0	0	0	0	0	0

Bits	Name	Description
15:0	AUX2_BIT_PATT_1	AUX Device 2 SPI bit pattern, bits 17-32. Only used if the bit pattern is longer than 16 bits. The contents of the bit pattern must be left-aligned such that the first bit for transmission is in the MSB. If the bit pattern is shorter than 32 bits, one or more of the LSBs is unused.

## 7.6 PIN\_CONFIG

### 7.6.1 PAD\_IRQ\_CFG

**Address: 0x0000 3D1C**

RW	15	14	13	12	11	10	9	8	7	6	5	4	3	2	1	0
	IRQ_OP_CFG	—				GPIO1_IRQ_EN		GPIO2_IRQ_EN	—			CONFIG4_IRQ_EN	SPI_SCK_IRQ_EN	—		
Default	0	0	0	0	0	0	0	0	0	0	0	0	0	0	0	0

Bits	Name	Description
15	IRQ_OP_CFG	IRQ output configuration 0 = (Default) CMOS 1 = Open drain
14:9	—	Reserved
8	GPIO1_IRQ_EN	IRQ output to GPIO1 0 = (Default) GPIO1 1 = IRQ output
7	GPIO2_IRQ_EN	IRQ output to GPIO2 0 = (Default) GPIO2 1 = IRQ output
6:5	—	Reserved
4	CONFIG4_IRQ_EN	CONFIG4 pin function select 0 = (Default) HW config/CH_IDLE 1 = IRQ output
3	SPI_SCK_IRQ_EN	IRQ output to SPI_SCK 0 = (Default) SPI_SCK 1 = IRQ output
2:0	—	Reserved

## 7.7 IRQ\_CONFIG

### 7.7.1 IRQ\_STS

**Address: 0x0000 3E04**

RO	15...8	7	6	5	4	3	2	1	0
	—								IRQ_STS
Default	0x00	0	0	0	0	0	0	0	0

Bits	Name	Description
15:1	—	Reserved
0	IRQ_STS	IRQ status. Logical OR of all unmasked x_INT interrupts. 0 = (Default) Not asserted 1 = Asserted

### 7.7.2 IRQ\_ADC\_EVENT\_INT

**Address: 0x0000 3E1C**

RW	15	14	13	12	11	10	9	8	7	6	5	4	3	2	1	0
	IN2_SIG_ACT_LOW_INT	IN1_SIG_ACT_LOW_INT	IN2_SIG_ACT_HIGH_INT	IN1_SIG_ACT_HIGH_INT	IN2_PAD_LOW_INT	IN1_PAD_LOW_INT	IN2_PAD_HIGH_INT	IN1_PAD_HIGH_INT	GAIN_CONFLICT_INT	—			IN2_CLIP_WARN_INT	IN1_CLIP_WARN_INT	—	
Default	0	0	0	0	0	0	0	0	0	0	0	0	0	0	0	0

Bits	Name	Description
15	IN2_SIG_ACT_LOW_INT	ADC Channel 2 signal-activity detection, input signal exceeds low-level threshold interrupt. Write 1 to clear. 0 = (Default) Normal 1 = Exceed LOW Th
14	IN1_SIG_ACT_LOW_INT	ADC Channel 1 signal-activity detection, input signal exceeds low-level threshold interrupt. Write 1 to clear. 0 = (Default) Normal 1 = Exceed LOW Th
13	IN2_SIG_ACT_HIGH_INT	ADC Channel 2 signal-activity detection, input signal exceeds high-level threshold interrupt. Write 1 to clear. 0 = (Default) Normal 1 = Exceed High Th

Bits	Name	Description
12	IN1_SIG_ACT_HIGH_INT	ADC Channel 1 signal-activity detection, input signal exceeds high-level threshold interrupt. Write 1 to clear. 0 = (Default) Normal 1 = Exceed High Th
11	IN2_PAD_LOW_INT	ADC Channel 2 PAD LD, input signal exceeds low-level threshold interrupt. Write 1 to clear. 0 = (Default) Normal 1 = Exceeds Low Th
10	IN1_PAD_LOW_INT	ADC Channel 1 PAD LD, input signal exceeds low-level threshold interrupt. Write 1 to clear. 0 = (Default) Normal 1 = Exceeds Low Th
9	IN2_PAD_HIGH_INT	ADC Channel 2 PAD LD, input signal exceeds high-level threshold interrupt. Write 1 to clear. 0 = (Default) Normal 1 = Exceed High Th
8	IN1_PAD_HIGH_INT	ADC Channel 1 PAD LD, input signal exceeds high-level threshold interrupt. Write 1 to clear. 0 = (Default) Normal 1 = Exceed High Th
7	GAIN_CONFLICT_INT	Gain updates both high gain and low gain concurrently interrupt. Write 1 to clear. 0 = (Default) Normal 1 = Update conflict
6:3	—	Reserved
2	IN2_CLIP_WARN_INT	Channel 2 clip-detect warning interrupt, rising-edge triggered. Write 1 to clear. 0 = (Default) Normal 1 = Clip detect
1	IN1_CLIP_WARN_INT	Channel 1 clip-detect warning interrupt, rising-edge triggered. Write 1 to clear. 0 = (Default) Normal 1 = Clip detect
0	—	Reserved

**7.7.3 IRQ\_HGC\_EVENT\_INT**
**Address: 0x0000 3E1E**

RW	15..8	7	6	5	4	3	2	1	0
	—		—		HGC_SPI_ERROR_INT	HGC_ABORT_ERROR_INT	—	HGC_ERROR_INT	HGC_DONE_INT
Default	0x00	0	0	0	0	0	0	0	0

Bits	Name	Description
15:5	—	Reserved
4	HGC_SPI_ERROR_INT	HGC Gain update SPI error interrupt. Write 1 to clear. 0 = (Default) Normal 1 = HGC update SPI error
3	HGC_ABORT_ERROR_INT	HGC Gain update aborted interrupt. Write 1 to clear. 0 = (Default) Normal 1 = HGC update aborted
2	—	Reserved
1	HGC_ERROR_INT	HGC Gain updates failed interrupt. Write 1 to clear. 0 = (Default) Normal 1 = HGC update failed
0	HGC_DONE_INT	HGC Gain updates have completed successfully interrupt, rising-edge triggered. Write 1 to clear. 0 = (Default) Normal 1 = HGC gain changed

**7.7.4 IRQ\_ADC\_EVENT\_MASK**
**Address: 0x0000 3E2C**

RW	15	14	13	12	11	10	9	8	7	6	5	4	3	2	1	0
	IN2_SIG_ACT_LOW_MASK	IN1_SIG_ACT_LOW_MASK	IN2_SIG_ACT_HIGH_MASK	IN1_SIG_ACT_HIGH_MASK	IN2_PAD_LOW_MASK	IN1_PAD_LOW_MASK	IN2_PAD_HIGH_MASK	IN1_PAD_HIGH_MASK	GAIN_CONFLICT_MASK			—		IN2_CLIP_WARN_MASK	IN1_CLIP_WARN_MASK	—
Default	1	1	0	0	1	1	1	1	1	0	0	0	0	0	0	0

Bits	Name	Description
15	IN2_SIG_ACT_LOW_MASK	ADC Channel 2 signal-activity detection, input signal level exceeds low-level threshold interrupt mask. 0 = Do Not Mask 1 = (Default) Mask Interrupt
14	IN1_SIG_ACT_LOW_MASK	ADC Channel 1 signal-activity detection, input signal level exceeds low-level threshold interrupt mask. 0 = Do Not Mask 1 = (Default) Mask Interrupt
13	IN2_SIG_ACT_HIGH_MASK	ADC Channel 2 signal-activity detection, input signal level exceeds high-level threshold interrupt mask. 0 = (Default) Do Not Mask 1 = Mask Interrupt
12	IN1_SIG_ACT_HIGH_MASK	ADC Channel 1 signal-activity detection, input signal level exceeds high-level threshold interrupt mask. 0 = (Default) Do Not Mask 1 = Mask Interrupt
11	IN2_PAD_LOW_MASK	ADC Channel 2 PAD LD, input signal exceeds low-level threshold interrupt mask. 0 = Do Not Mask 1 = (Default) Mask Interrupt
10	IN1_PAD_LOW_MASK	ADC Channel 1 PAD LD, input signal exceeds low-level threshold interrupt mask. 0 = Do Not Mask 1 = (Default) Mask Interrupt
9	IN2_PAD_HIGH_MASK	ADC Channel 2 PAD LD, input signal exceeds high-level threshold interrupt mask. 0 = Do Not Mask 1 = (Default) Mask Interrupt
8	IN1_PAD_HIGH_MASK	ADC Channel 1 PAD LD, input signal exceeds high-level threshold interrupt mask. 0 = Do Not Mask 1 = (Default) Mask Interrupt
7	GAIN_CONFLICT_MASK	Gain updates both high gain and low gain interrupt mask. 0 = Do Not Mask 1 = (Default) Mask Interrupt
6:3	—	Reserved
2	IN2_CLIP_WARN_MASK	ADC Channel 2 clip-detect warning interrupt mask. 0 = (Default) Do Not Mask 1 = Mask Interrupt
1	IN1_CLIP_WARN_MASK	ADC Channel 1 clip-detect warning interrupt mask. 0 = (Default) Do Not Mask 1 = Mask Interrupt
0	—	Reserved

**7.7.5 IRQ\_HGC\_EVENT\_MASK**
**Address: 0x0000 3E2E**

RW	15...8	7	6	5	4	3	2	1	0
	—	—	—	—	HGC_SPI_ERROR_MASK	HGC_ABORT_MASK	—	HGC_ERROR_MASK	HGC_DONE_MASK
Default	0x00	0	0	0	1	1	0	1	1

Bits	Name	Description
15:5	—	Reserved
4	HGC_SPI_ERROR_MASK	HGC Gain update SPI error interrupt mask. 0 = Do Not Mask 1 = (Default) Mask Interrupt
3	HGC_ABORT_MASK	HGC Gain update aborted interrupt mask. 0 = Do Not Mask 1 = (Default) Mask Interrupt
2	—	Reserved

Bits	Name	Description
1	HGC_ERROR_MASK	HGC Gain updates failed interrupt mask. 0 = Do Not Mask 1 = (Default) Mask Interrupt
0	HGC_DONE_MASK	HGC Gain updates have completed interrupt mask. 0 = Do Not Mask 1 = (Default) Mask Interrupt

**7.7.6 IRQ\_ADC\_EVENT\_STS**
**Address: 0x0000 3E5C**

RO	15	14	13	12	11	10	9	8	7	6	5	4	3	2	1	0
	IN2_SIG_ACT_LOW_STS	IN1_SIG_ACT_LOW_STS	IN2_SIG_ACT_HIGH_STS	IN1_SIG_ACT_HIGH_STS	IN2_PAD_LOW_STS	IN1_PAD_LOW_STS	IN2_PAD_HIGH_STS	IN1_PAD_HIGH_STS	—				IN2_CLIP_WARN_STS	IN1_CLIP_WARN_STS	—	
Default	0	0	0	0	0	0	0	0	0	0	0	0	0	0	0	0

Bits	Name	Description
15	IN2_SIG_ACT_LOW_STS	ADC Channel 2 signal-activity detection, input signal exceeds low-level threshold status. 0 = (Default) Not asserted 1 = Asserted
14	IN1_SIG_ACT_LOW_STS	ADC Channel 1 signal-activity detection, input signal exceeds low-level threshold status. 0 = (Default) Not asserted 1 = Asserted
13	IN2_SIG_ACT_HIGH_STS	ADC Channel 2 signal-activity detection, input signal exceeds high-level threshold status. 0 = (Default) Not asserted 1 = Asserted
12	IN1_SIG_ACT_HIGH_STS	ADC Channel 1 signal-activity detection, input signal exceeds high-level threshold status. 0 = (Default) Not asserted 1 = Asserted
11	IN2_PAD_LOW_STS	ADC Channel 2 PAD LD, input signal exceeds low-level threshold status. 0 = (Default) Not asserted 1 = Asserted
10	IN1_PAD_LOW_STS	ADC Channel 1 PAD LD, input signal exceeds low-level threshold status. 0 = (Default) Not asserted 1 = Asserted
9	IN2_PAD_HIGH_STS	ADC Channel 2 PAD LD, input signal exceeds high-level threshold status. 0 = (Default) Not asserted 1 = Asserted
8	IN1_PAD_HIGH_STS	ADC Channel 1 PAD LD, input signal exceeds high-level threshold status. 0 = (Default) Not asserted 1 = Asserted
7:3	—	Reserved
2	IN2_CLIP_WARN_STS	ADC Channel 1 clip warning status. 0 = (Default) Not asserted 1 = Asserted
1	IN1_CLIP_WARN_STS	ADC Channel 1 clip warning status. 0 = (Default) Not asserted 1 = Asserted
0	—	Reserved

## 8 Thermal Characteristic

Table 8-1. Typical JEDEC Four-Layer, 2s2p Board Thermal Characteristics

Parameter	Symbol	QFN	Units
Junction-to-ambient thermal resistance	$\theta_{JA}$	30.25	$^{\circ}\text{C}/\text{W}$
Junction-to-board thermal resistance	$\theta_{JB}$	17.17	$^{\circ}\text{C}/\text{W}$
Junction-to-case (top) thermal resistance	$\theta_{JC}$	69.26	$^{\circ}\text{C}/\text{W}$
Junction-to-board thermal-characterization parameter	$\Psi_{JB}$	15.99	$^{\circ}\text{C}/\text{W}$
Junction-to-package-top thermal-characterization parameter	$\Psi_{JT}$	2.82	$^{\circ}\text{C}/\text{W}$

**Notes:**

- Natural convection at the maximum recommended operating temperature  $T_A$  (see Table 3-2)
- Four-layer, 2s2p PCB as specified by JESD51-9 and JESD51-11; dimensions: 101.5 x 114.5 x 1.6 mm
- Thermal parameters as defined by JESD51-12

## 9 Package Dimensions

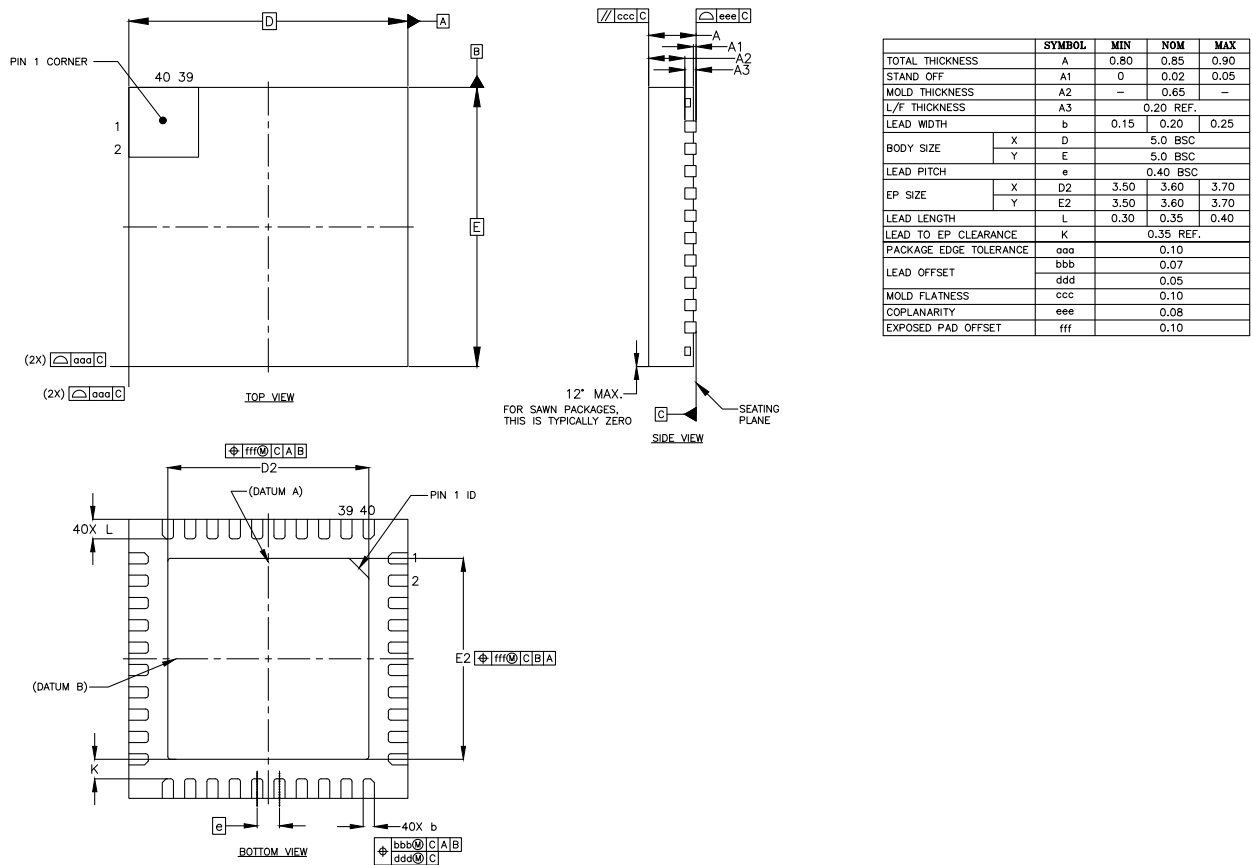
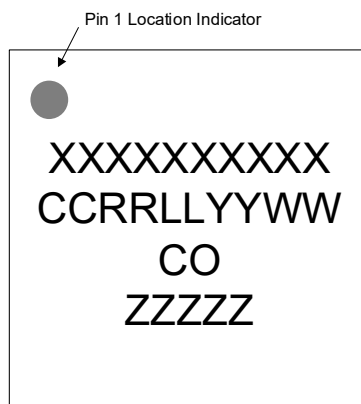


Figure 9-1. QFN Package Drawing

## 10 Package Marking


**Top Side Brand**

Line 1: Part number  
 Line 2: Package mark  
 Line 3: Country of origin (CO)  
 Line 4: Encoded wafer/device ID

**Package Mark Fields**

CC = Cirrus Logic Index Code  
 RR = Device revision code  
 LL = Lot sequence code  
 YY = Year of manufacture  
 WW = Work week of manufacture

**Figure 10-1. Package Marking**

## 11 Ordering Information

**Table 11-1. Ordering Information**

Product	Description	Package	Environmental Certifications	Grade	Temperature Range	Container	Orderable Part Number
CS4233S	High Performance Two-Channel Audio Codec	40-pin QFN	RoHS Compliant	Commercial	-40 to +85°C	Tray	CS4233S-DN
						Tape and Reel	CS4233S-DNR

## 12 References

- NXP Semiconductors, UM10204 Rev. 7, October 2021, *I2C-Bus Specification and User Manual*, <http://www.nxp.com>

## 13 Revision History

**Important:** Please check [www.cirrus.com](http://www.cirrus.com) or with your Cirrus Logic sales representative to confirm that you are using the latest revision of this document and to determine whether there are errata associated with this device.

**Table 13-1. Revision History**

Revision	Change
A2 MAY 2026	• Released for public distribution
A1 NOV 2025	• Initial version

---

## Contacting Cirrus Logic Support

For all product questions and inquiries, contact a Cirrus Logic Sales Representative.

To find one nearest you, go to [www.cirrus.com](http://www.cirrus.com).

---

### IMPORTANT NOTICE

"Advance" product information describes products that are in development and subject to substantial development changes. For the purposes of our terms and conditions of sale, "Preliminary" or "Advanced" datasheets are nonfinal datasheets that include, but are not limited to, datasheets marked as "Target", "Advance", "Product Preview", "Preliminary Technical Data" and/or "Preproduction." Products provided with any such datasheet are therefore subject to relevant terms and conditions associated with "Preliminary" or "Advanced" designations, as set out in our terms and conditions of sale, including but not limited to that Cirrus Logic expressly disclaims any warranties with respect to such products. The products and services of Cirrus Logic International (UK) Limited; Cirrus Logic, Inc.; and other companies in the Cirrus Logic group (collectively either "Cirrus Logic" or "Cirrus") are sold subject to Cirrus Logic's terms and conditions of sale supplied at the time of order acknowledgment, including those pertaining to warranty, indemnification, and limitation of liability. Software is provided pursuant to applicable license terms. Cirrus Logic reserves the right to make changes to its products and specifications or to discontinue any product or service without notice. Customers should therefore obtain the latest version of relevant information from Cirrus Logic to verify that the information is current and complete. Testing and other quality control techniques are utilized to the extent Cirrus Logic deems necessary. Specific testing of all parameters of each device is not necessarily performed. In order to minimize risks associated with customer applications, the customer must use adequate design and operating safeguards to minimize inherent or procedural hazards. Cirrus Logic is not liable for applications assistance or customer product design. The customer is solely responsible for its overall product design, end-use applications, and system security, including the specific manner in which it uses Cirrus Logic components. Certain uses or product designs may require an intellectual property license from a third party. Features and operations described herein are for illustrative purposes only and do not constitute a suggestion or instruction to adopt a particular product design or a particular mode of operation for a Cirrus Logic component.

CIRRUS LOGIC PRODUCTS ARE NOT DESIGNED, TESTED, INTENDED OR WARRANTED FOR USE (1) WITH OR IN IMPLANTABLE PRODUCTS OR FDA/ MHRA CLASS III (OR EQUIVALENT CLASSIFICATION) MEDICAL DEVICES, OR (2) IN ANY PRODUCTS, APPLICATIONS OR SYSTEMS, INCLUDING WITHOUT LIMITATION LIFE-CRITICAL MEDICAL EQUIPMENT OR SAFETY OR SECURITY EQUIPMENT, WHERE MALFUNCTION OF THE PRODUCT COULD CAUSE PERSONAL INJURY, DEATH, SEVERE PROPERTY DAMAGE OR SEVERE ENVIRONMENTAL HARM. INCLUSION OF CIRRUS LOGIC PRODUCTS IN SUCH APPLICATIONS IS UNDERSTOOD TO BE FULLY AT THE CUSTOMER'S RISK AND CIRRUS LOGIC DISCLAIMS AND MAKES NO WARRANTY, EXPRESS, STATUTORY OR IMPLIED, INCLUDING THE IMPLIED WARRANTIES OF MERCHANTABILITY AND FITNESS FOR PARTICULAR PURPOSE, WITH REGARD TO ANY CIRRUS LOGIC PRODUCT THAT IS USED IN SUCH A MANNER. IF THE CUSTOMER OR CUSTOMER'S CUSTOMER USES OR PERMITS THE USE OF CIRRUS LOGIC PRODUCTS IN SUCH A MANNER, CUSTOMER AGREES, BY SUCH USE, TO FULLY INDEMNIFY CIRRUS LOGIC, ITS OFFICERS, DIRECTORS, EMPLOYEES, DISTRIBUTORS AND OTHER AGENTS FROM ANY AND ALL LIABILITY, INCLUDING ATTORNEYS' FEES AND COSTS, THAT MAY RESULT FROM OR ARISE IN CONNECTION WITH THESE USES.

This document is the property of Cirrus Logic, and you may not use this document in connection with any legal analysis concerning Cirrus Logic products described herein. No license to any technology or intellectual property right of Cirrus Logic or any third party is granted herein, including but not limited to any patent right, copyright, mask work right, or other intellectual property rights. Any provision or publication of any third party's products or services does not constitute Cirrus Logic's approval, license, warranty or endorsement thereof. Cirrus Logic gives consent for copies to be made of the information contained herein only for use within your organization with respect to Cirrus Logic integrated circuits or other products of Cirrus Logic, and only if the reproduction is without alteration and is accompanied by all associated copyright, proprietary and other notices and conditions (including this notice). This consent does not extend to other copying such as copying for general distribution, advertising or promotional purposes, or for creating any work for resale. This document and its information is provided "AS IS" without warranty of any kind (express or implied). All statutory warranties and conditions are excluded to the fullest extent possible. No responsibility is assumed by Cirrus Logic for the use of information herein, including use of this information as the basis for manufacture or sale of any items, or for infringement of patents or other rights of third parties. Cirrus Logic, Cirrus, the Cirrus Logic logo design, and SoundClear are among the trademarks of Cirrus Logic. Other brand and product names may be trademarks or service marks of their respective owners.

Copyright © 2025–2026 Cirrus Logic, Inc. and Cirrus Logic International Semiconductor Ltd. All rights reserved.

SPI is a trademark of Motorola.