

High Performance Two-Channel Audio DAC

Features

- High performance two-channel DAC
 - Differential analog architecture
 - High-resolution 32-bit digital design
 - Low-latency digital filters and digital volume control
- Crystal oscillator interface
- Sample timing alignment across multiple devices
- Audio serial port (ASP) sample rates up to 384 kHz
 - I²S, left-justified, and TDM data formats
- Hardware and software control modes
 - I²C control port up to 1 MHz
 - SPI control port up to 24 MHz
 - Hardware control with no host processor required
- Single-supply operation at 3.3 V
 - Support for 1.8 V–3.3 V digital input/output
 - 40-pin QFN package

Specifications

- Enhanced oversampling sigma-delta voltage-output DAC
 - 110 dB dynamic range (A-weighted)
 - –100 dB total harmonic distortion + noise (THD+N)
 - 4.6/F_s group delay at 48 kHz sample rate
 - 2 V_{RMS} full-scale output

Applications

- A/V receivers
- Digital mixing consoles
- Powered speakers
- Power amplifiers
- High-performance speakers and soundbars
- DAW interfaces
- Musical instruments
- Commercial audio systems

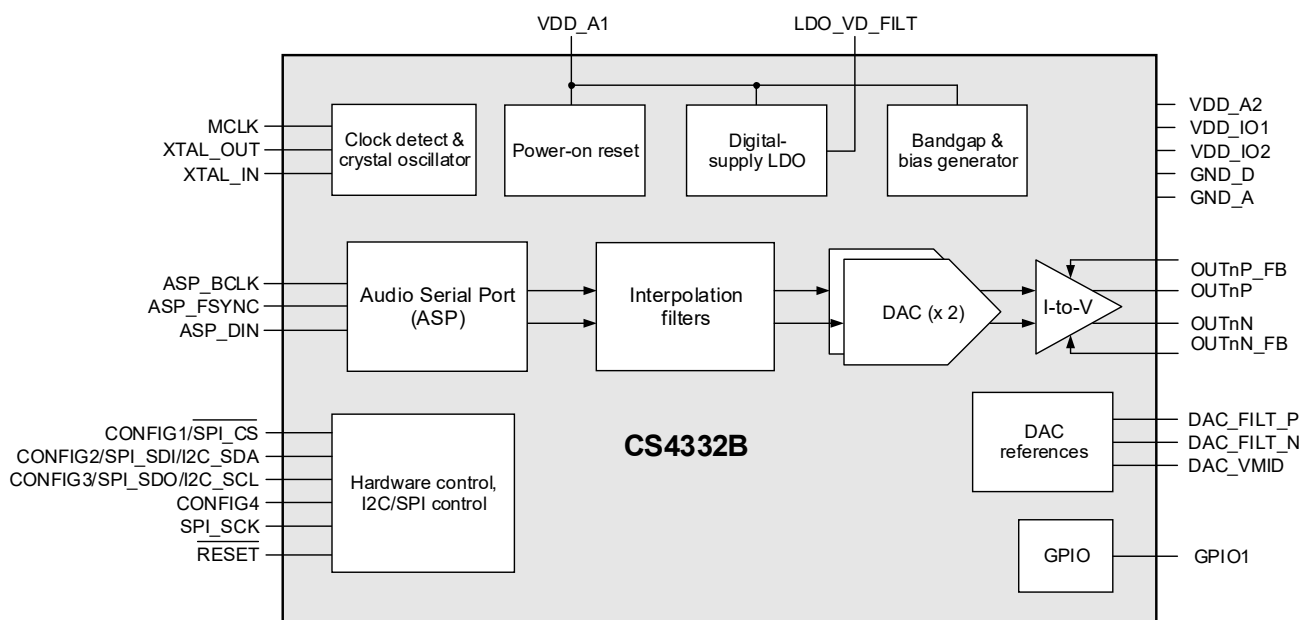

Advanced Product Information

This document contains information for a product under development. Cirrus Logic reserves the right to modify this product without notice.

General Description

The CS4332B is a high-performance, 32-bit resolution, two-channel DAC. The CS4332B supports differential analog output, and 32-bit digital input via the audio serial port (ASP) at sample rates up to 384 kHz.

The voltage-output DAC incorporates a proprietary analog FIR architecture to reduce out-of-band noise and minimize the external component requirements. Low-latency digital-interpolation filters are provided. The analog output supports configurable out-of-band filtering, enabling flexible integration, and optimal dynamic range for the target application.

The CS4332B can be configured using a control interface supporting I²C and SPI modes of operation. The device can also be operated in hardware mode, using external resistors to select the required configuration. Multiple hardware-control options are supported, including system clocking source, ASP format, and sample rate.

The low-latency digital filters are optimized for the applicable sample rate. A de-emphasis filter is provided in the output path.

The ASP supports operation in I²S, left-justified, and TDM data formats. Tristate control of the data-output pin allows multiple devices to operate on a shared bus.

Clocking for the CS4332B is provided by a separate clock source (MCLK) or else from the crystal oscillator. The DAC-conversion timing is referenced to the ASP data frame, enabling time-aligned operation across multiple devices sharing a common data bus.

The CS4332B can be powered from a single 3.3 V supply. Digital input at 1.8 V logic levels is also possible using a separate external supply. The device combines high performance with low power consumption.

The CS4332B is available in a commercial-grade 0.4 mm pitch, 40-pin QFN package for operation from -40°C to +85°C.

See [Section 11](#) for ordering information.

Table of Contents

1 Pin Assignments and Descriptions	4
1.1 40-Pin QFN (Top View, Through-Package)	4
1.2 QFN Pin Descriptions	4
1.3 Termination of Unused Pins	6
1.4 Electrostatic Discharge (ESD) Protection	6
2 Typical Connection Diagrams	7
3 Characteristics and Specifications	8
Table 3-1. Parameter Definitions	8
Table 3-2. Recommended Operating Conditions	8
Table 3-3. Absolute Maximum Ratings	8
Table 3-4. DAC Path Characteristics	9
Table 3-5. DAC Filter Characteristics	9
Table 3-6. DAC High-Pass Filter (HPF)	10
Table 3-7. Device Power Consumption	10
Table 3-8. Digital Interface Specifications and Characteristics	10
Table 3-9. DC Characteristics	10
Table 3-10. Switching Specifications—Reset and Clock References	11
Table 3-11. Switching Specifications—Audio Serial Port (ASP)	11
Table 3-12. Switching Specifications—I ² C Control Port	13
Table 3-13. Switching Specifications—SPI Control Port	14
4 Functional Description	15
4.1 Device Power and Reset	15
4.2 Hardware Configuration	15
4.3 Software Configuration	16
4.4 System Clocking	17
4.5 DAC and Analog Output	19
4.6 Audio Serial Port (ASP)	21
4.7 I ² C/SPI Control Port	26
4.8 Device ID	30
5 Applications	31
5.1 Output Buffer Circuit	31
5.2 Crystal Component Selection	35
6 Register Quick Reference	37
6.1 DEVID	37
6.2 CONFIG	37
6.3 OUTPUT_PATH	38
7 Register Descriptions	39
7.1 DEVID	39
7.2 CONFIG	40
7.3 OUTPUT_PATH	41
8 Thermal Characteristic	44
9 Package Dimensions	44
10 Package Marking	45
11 Ordering Information	45
12 References	45
13 Revision History	45

1 Pin Assignments and Descriptions

1.1 40-Pin QFN (Top View, Through-Package)

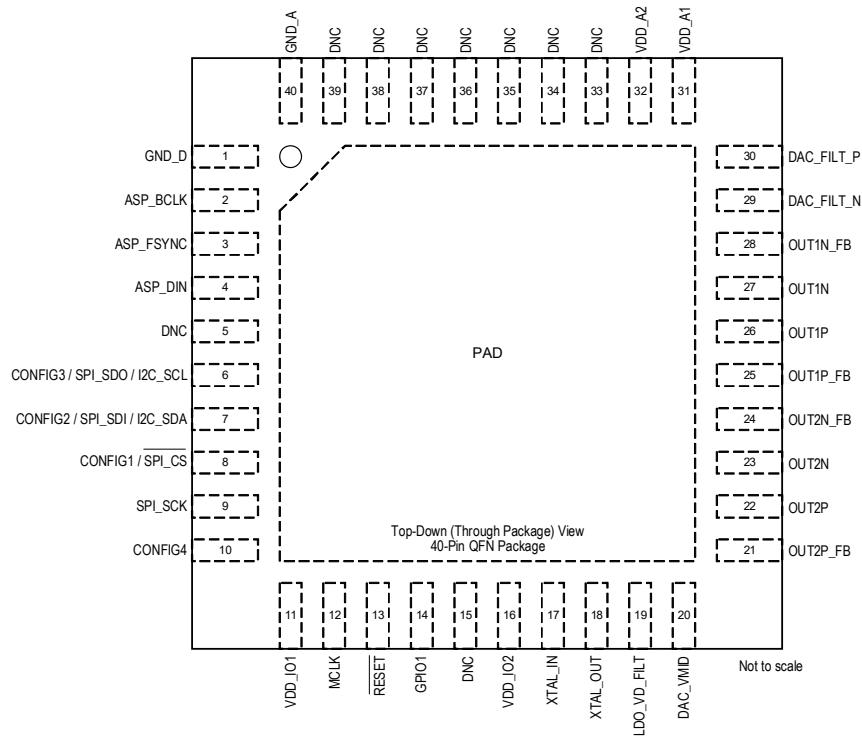

Figure 1-1. QFN 40-Pin Diagram (Top View, Through Package)

1.2 QFN Pin Descriptions

Table 1-1. QFN Pin Descriptions

Pin Name	Pin #	Power Supply	I/O	Description
Digital I/O				
ASP_BCLK	2	VDD_IO1	I/O	Audio serial port bit clock.
ASP_DIN	4	VDD_IO1	I	Audio serial port data input.
ASP_FSYNC	3	VDD_IO1	I/O	Audio serial port frame sync.
GPIO1	14	VDD_IO2	I/O	General-purpose input/output.
MCLK	12	VDD_IO1	I/O	Master clock input/output.
$\overline{\text{RESET}}$	13	VDD_IO1	I	Hardware reset control (active low).
XTAL_IN	17	VDD_IO2	I/O	Input for an external crystal/General-purpose input/output.
XTAL_OUT	18	VDD_IO2	I/O	Output for an external crystal/General-purpose input/output.
Analog I/O				
$\overline{\text{CONFIG1/SPI_CS}}$	8	VDD_IO1	I	Hardware control pins.
CONFIG2/SPI_SDI/I2C_SDA	7	VDD_IO1	I/O	In software control mode, CONFIG1-3 support the SPI/I ² C interface.
CONFIG3/SPI_SDO/I2C_SCL	6	VDD_IO1	I/O	In software control mode, CONFIG1 selects the I ² C target address.
CONFIG4	10	VDD_IO1	I	
SPI_SCK	9	VDD_IO1	I	SPI clock input.
DAC_FILT_N	29	VDD_A1	O	DAC external capacitor connection.
DAC_FILT_P	30	VDD_A1	O	

Table 1-1. QFN Pin Descriptions (Cont.)

Pin Name	Pin #	Power Supply	I/O	Description
DAC_VMID	20	VDD_A1	O	DAC mid-rail voltage reference output.
LDO_VD_FILTER	19	VDD_A1	O	LDO_D regulator external capacitor connection.
OUT1N_FB	28	VDD_A1	O	Analog Output 1 feedback connection.
OUT1P_FB	25	VDD_A1	O	
OUT2N_FB	24	VDD_A1	O	Analog Output 2 feedback connection.
OUT2P_FB	21	VDD_A1	O	
OUT1N	27	VDD_A1	O	Analog Output 1.
OUT1P	26	VDD_A1	O	
OUT2N	23	VDD_A1	O	Analog Output 2.
OUT2P	22	VDD_A1	O	
Power Supplies				
VDD_A1	31	—	—	Analog Supply 1.
VDD_A2	32	—	—	Analog Supply 2.
VDD_IO1	11	—	—	Digital I/O Supply 1.
VDD_IO2	16	—	—	Digital I/O Supply 2.
GND_A	40, PAD	—	—	Analog ground 1.
GND_D	1	—	—	Digital ground 1.
No Connect				
DNC	5, 15, 33, 34, 35, 36, 37, 38, 39	—	—	Do not connect.

1. All ground pins, including the ground paddle, must be tied to a common ground plane directly underneath the CS4332B. It is recommended that each ground pin is connected separately to the ground plane, using multiple vias to connect the ground paddle.

1.3 Termination of Unused Pins

Table 1-2 shows the required termination for unused pins (i.e., if the functionality of the pin is not being used). Pins not listed must be connected as shown in the typical connection drawings (see Section 2).

Table 1-2. Termination of Unused Pins

Name	Termination if unused
MCLK ¹	Float
CONFIG3/SPI_SDO/I2C_SCL	10 kΩ pull-down to GND
CONFIG4	
GPIO1	
SPI_SCK	
XTAL_IN	
XTAL_OUT	
OUTnX ²	
RESET	Connect to VDD_IO1

1. If the system clock is provided by the crystal oscillator and an MCLK output is not required, MCLK should be left floating.

2. See Section 5.1.3 for requirements in case of single-ended output configurations.

1.4 Electrostatic Discharge (ESD) Protection



ESD-sensitive device. The CS4332B is manufactured on a CMOS process. Therefore, it is generically susceptible to damage from excessive static voltages. Proper ESD precautions must be taken while handling and storing this device. This device is qualified to current JEDEC ESD protection standards.

2 Typical Connection Diagrams

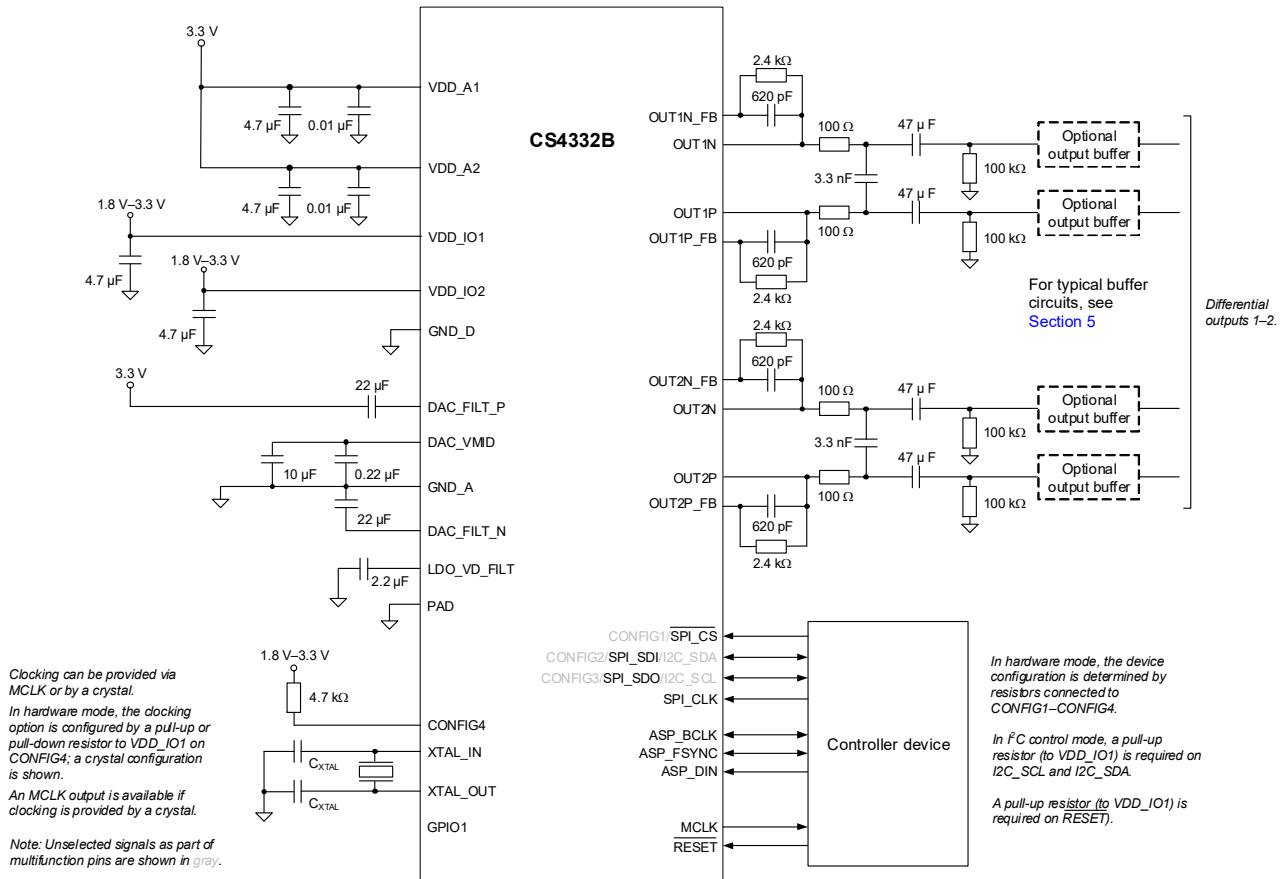

3 Characteristics and Specifications

Note: Table 3-1 defines parameters as they are characterized in this section. Default register field configurations are used unless specified otherwise in the test conditions.

Table 3-1. Parameter Definitions

Parameter	Definition
Channel separation	The difference in level between the active channel (driven to maximum full scale output) and the measured signal level in the idle channel at the test signal frequency. The active channel is configured and supplied with an appropriate input signal to drive a full scale output, with signal measured at the output of the associated idle channel.
Dynamic range	The difference in level between the maximum full-scale output signal and the sum of all harmonic distortion products plus noise with a low-level input signal applied (an input signal level 60 dB below full scale is used).
Power-supply rejection ratio (PSRR)	The ratio of a specified power supply variation relative to the output signal that results from it. PSRR is measured under quiescent signal path conditions.
Total harmonic distortion plus noise (THD+N)	The ratio of the RMS sum of the harmonic distortion products plus noise in the specified bandwidth relative to the RMS amplitude of the fundamental (i.e., test frequency) output.

Note: Unless specified otherwise, all performance measurements are for a 10 Hz to 20 kHz bandwidth.

Table 3-2. Recommended Operating Conditions

Test conditions (unless specified otherwise): Ground = GND = GND_A = PAD = GND_D = 0 V; voltages are with respect to ground.

Parameter		Symbol	Minimum	Maximum	Unit
DC power supply	Analog supply ¹	VDD_A1, VDD_A2	3.13	3.47	V
	Digital I/O supply	VDD_IO1, VDD_IO2	1.71	3.63	V
Supply ramp up/down (all supplies)		t _{PWR-UD}	0.01	10	ms
Ambient temperature	Commercial Grade	T _A	-40	85	°C

Note: The device is fully functional and meets all parametric specifications in this section if operated within the specified conditions. Functionality and parametric performance is not guaranteed or implied outside of these limits. Operation outside of these limits may adversely affect device reliability.

1. The VDD_A1 and VDD_A2 rails should be tied together and powered from a single supply. The associated power domain is referred to as VDD_A.

Table 3-3. Absolute Maximum Ratings

Test conditions (unless specified otherwise): Ground = GND = GND_A = PAD = GND_D = 0 V; voltages are with respect to ground.

Parameter		Symbol	Minimum	Maximum	Unit
DC power supply	Analog supply ¹	VDD_A1, VDD_A2	-0.3	4.32	V
	Digital I/O supply	VDD_IO1, VDD_IO2	-0.3	4.32	V
External voltage applied to digital input/output	VDD_IO1 logic pins	V _{INDI}	-0.3	VDD_IO1 + 0.3	V
	VDD_IO2 logic pins		-0.3	VDD_IO2 + 0.3	V
External voltage applied to analog inputs		V _{INAI}	-0.3	VDD_A + 0.3	V
Input current	digital input/output	I _{IN}	—	±10	mA
	analog inputs		—	±10	mA
Ambient operating temperature		T _A	-40	+115	°C
Junction operating temperature		T _J	-40	+125	°C
Storage temperature		T _{STG}	-65	+150	°C

Caution: Stresses beyond “Absolute Maximum Ratings” levels may cause permanent damage to the device. These levels are stress ratings only, and functional operation of the device at these or any other conditions beyond those indicated in Table 3-2 is not implied. Exposure to absolute maximum rating conditions for extended periods may affect device reliability.

1. The VDD_A1 and VDD_A2 rails should be tied together and powered from a single supply. The associated power domain is referred to as VDD_A.

Table 3-4. DAC Path Characteristics

Test conditions (unless specified otherwise): External components as shown in Fig. 2-1 incorporating the typical output circuit illustrated in Fig. 5-1; VDD_A = VDD_IO1 = VDD_IO2 = 3.3 V; Ground = GND = GND_A = PAD = GND_D = 0 V; voltages are with respect to ground; T_A = +25°C; 1 kHz sine wave test signal; F_s = 48 kHz, 32-bit audio data, MCLK = 24.576 MHz.

Parameter		Min	Typ	Max	Units
Full scale differential output signal level (OUTnP to OUTnN)	0 dBFS input	—	2.00	—	V _{RMS}
Dynamic range	A-weighted	107	110	—	dB
	unweighted	104	107	—	dB
THD+N	0 dBFS input	—	−100	−94	dB
	−20 dBFS input	—	−87	—	dB
	−60 dBFS input	—	−47	—	dB
Idle channel noise	A-weighted	—	6.32	—	μV _{RMS}
Channel separation	1 kHz	—	110	—	dB
	20 kHz	—	100	—	dB
DC offset error		—	±0.5	—	mV
PSRR (VDD_A)	100 mV (peak-peak) 1 kHz sine wave	—	75	—	dB
Load resistance		3	—	—	kΩ
Load capacitance		—	—	100	pF

Table 3-5. DAC Filter Characteristics

Test conditions (unless specified otherwise): VDD_A = VDD_IO1 = VDD_IO2 = 3.3 V; Ground = GND = GND_A = PAD = GND_D = 0 V; voltages are with respect to ground; T_A = +25°C; 1 kHz sine wave test signal; F_s = 48 kHz, 32-bit audio data.

Parameter		Min	Typ	Max	Units	
F _s = 16 kHz	Passband	to −3 dB corner	—	—	0.49	F _s
	Passband ripple	f ≤ 0.45 F _s	−0.001	—	0.001	dB
	Stopband attenuation	f ≥ 0.55 F _s	100	—	—	dB
	Group delay ¹		—	32.5/F _s	—	s
F _s = 32 kHz	Passband	to −3 dB corner	—	—	0.49	F _s
	Passband ripple	f ≤ 0.45 F _s	−0.001	—	0.001	dB
	Stopband attenuation	f ≥ 0.55 F _s	100	—	—	dB
	Group delay ¹		—	32.5/F _s	—	s
F _s = 44.1 kHz or 48 kHz	Passband	to −3 dB corner	—	—	0.47	F _s
	Passband ripple	f ≤ 0.42 F _s	−0.004	—	0.005	dB
	Stopband attenuation	f ≥ 0.59 F _s	101	—	—	dB
	Group delay ¹		—	4.6/F _s	—	s
F _s = 88.2 kHz or 96 kHz	Passband	to −3 dB corner	—	—	0.35	F _s
	Passband ripple	f ≤ 0.23 F _s	−0.001	—	0.001	dB
	Stopband attenuation	f ≥ 0.55 F _s	101	—	—	dB
	Group delay ¹		—	5.2/F _s	—	s
F _s = 176.4 kHz or 192 kHz	Passband	to −3 dB corner	—	—	0.28	F _s
	Passband ripple	f ≤ 0.11 F _s	−0.001	—	0.001	dB
	Stopband attenuation	f ≥ 0.55 F _s	109	—	—	dB
	Group delay ¹		—	6.7/F _s	—	s
F _s = 352.8 kHz or 384 kHz	Passband	to −3 dB corner	—	—	0.22	F _s
	Passband ripple	f ≤ 0.11 F _s	−0.001	—	0.000	dB
	Stopband attenuation	f ≥ 0.55 F _s	116	—	—	dB
	Group delay ¹		—	7.6/F _s	—	s

1. Group delay is measured from the start of the FSYNC frame containing the audio data on the ASP_DIN pin to the time at which the signal is presented on the output pins (OUTnP/OUTnN).

Table 3-6. DAC High-Pass Filter (HPF)

Test conditions (unless specified otherwise): VDD_A = VDD_IO1 = VDD_IO2 = 3.3 V; Ground = GND = GND_A = PAD = GND_D = 0 V; voltages are with respect to ground; T_A = +25°C; 1 kHz sine wave test signal; F_s = 48 kHz, 32-bit audio data.

Parameter		Min	Typ	Max	Units
Passband	-0.01 dB corner	—	19	—	Hz
	-3 dB corner	—	1	—	Hz
Phase deviation	f = 20 Hz	—	0.001	—	degree
Filter settling time		—	0.4	—	s

Table 3-7. Device Power Consumption

Test conditions (unless specified otherwise): VDD_A = VDD_IO1 = VDD_IO2 = 3.3 V; Ground = GND = GND_A = PAD = GND_D = 0 V; voltages are with respect to ground; T_A = +25°C; 1 kHz sine wave test signal; F_s = 48 kHz, 32-bit audio data.

Use Configuration		Typical Current (mA)			Total Power (mW)
		I _{VDD_A}	I _{VDD_IO1}	I _{VDD_IO2}	
Reset	RESET = Logic 0	0.70	0.04	0.04	2.574

Table 3-8. Digital Interface Specifications and Characteristics

Test conditions (unless specified otherwise): Ground = GND = GND_A = PAD = GND_D = 0 V; voltages are with respect to ground; T_A = +25°C.

Parameter		Symbol	Minimum	Maximum	Unit
Input leakage current (per pin)		I _{IN}	—	±10	μA
Input capacitance (per pin)		C _{IN}	—	5	pF
Digital I/O (VDD_IO1 logic pins; see Section 1)	High-level output	V _{OH}	0.9×VDD_IO1	—	V
	Low-level output	V _{OL}	—	0.1×VDD_IO1	V
	High-level input	V _{IH}	0.7×VDD_IO1	—	V
	Low-level input	V _{IL}	—	0.3×VDD_IO1	V
Digital I/O (VDD_IO2 logic pins; see Section 1)	High-level output	V _{OH}	0.9×VDD_IO2	—	V
	Low-level output	V _{OL}	—	0.1×VDD_IO2	V
	High-level input	V _{IH}	0.7×VDD_IO2	—	V
	Low-level input	V _{IL}	—	0.3×VDD_IO2	V

Table 3-9. DC Characteristics

Test conditions (unless specified otherwise): VDD_A = VDD_IO1 = VDD_IO2 = 3.3 V; Ground = GND = GND_A = PAD = GND_D = 0 V; voltages are with respect to ground; T_A = +25°C.

Parameter		Minimum	Typical	Maximum	Unit	
LDO_VD_FILT	Nominal voltage	—	1.2	—	V	
DAC_FILT ¹	Nominal voltage	VDD_A to DAC_FILT_P	—	1.95	—	V
		DAC_FILT_N to GND	—	1.9	—	V
DAC_VMID	Nominal voltage	—	1.65	—	V	
	Maximum output current	—	50	—	nA	
VDD_A power-on reset (POR) threshold (V _{POR})	VDD_A rising	2.0	—	2.8	V	
	VDD_A falling	2.0	—	2.8	V	
VDD_IO1 power-on reset (POR) threshold (V _{POR})	VDD_IO1 rising	1.08	—	1.58	V	
	VDD_IO1 falling	0.99	—	1.43	V	
VDD_IO2 power-on reset (POR) threshold (V _{POR})	VDD_IO2 rising	0.45	—	0.75	V	
	VDD_IO2 falling	0.45	—	0.74	V	

1. DAC_FILT characteristics are provided as a guide for external component selection. The output current (arising from capacitor leakage) must be less than the maximum output current of the DAC_FILT_x pin.

Table 3-10. Switching Specifications—Reset and Clock References

Test conditions (unless specified otherwise): VDD_A = VDD_IO1 = VDD_IO2 = 3.3 V; Ground = GND = GND_A = PAD = GND_D = 0 V; voltages are with respect to ground; T_A = +25°C.

Parameter		Symbol	Minimum	Typical	Maximum	Unit
Reset	RESET low (logic 0) pulse width	t _{RLPW}	1	—	—	ms
	RESET rising edge to control port active	t _{IRS}	—	—	5	ms
MCLK input	MCLK frequency	f _{MCLK}	—	24.576	—	MHz
			—	22.5792	—	MHz
			—	49.152	—	MHz
			—	45.1584	—	MHz
	MCLK duty cycle	D _{MCLK}	45	—	55	%
	MCLK frequency tolerance	—	-1	—	1	%
MCLK output	MCLK frequency	f _{MCLK}	—	24.576	—	MHz
			—	22.5792	—	MHz
			—	49.152	—	MHz
			—	45.1584	—	MHz
	MCLK duty cycle	D _{MCLK}	45	—	55	%
	MCLK frequency accuracy	—	-1	—	1	%
Crystal	Oscillator frequency	f _{XTAL}	—	24.576	—	MHz
			—	22.5792	—	MHz
			—	49.152	—	MHz
			—	45.1584	—	MHz
	Interface transconductance			26	—	mS
		VDD_IO2 = 3.3 V	—	43	—	mS
		VDD_IO2 = 1.8 V	—	—	—	mS

Table 3-11. Switching Specifications—Audio Serial Port (ASP)

Test conditions (unless specified otherwise): VDD_A = VDD_IO2 = 3.3 V; Ground = GND = GND_A = PAD = GND_D = 0 V; voltages are with respect to ground; input timings are measured at V_{IL} and V_{IH} thresholds, output timings are measured at V_{OL} and V_{OH} thresholds for VDD_IO1 logic (as specified in Table 3-8); T_A = 25°C.

Parameter 1,2		Symbol	Minimum	Maximum	Unit
Secondary Mode, VDD_IO1 = 3.3 V	ASP_FSYNC input sample/frame rate	F _s	16	384	kHz
	ASP_FSYNC pulse width	t _{HI:FSYNC}	1/f _{ASP_BCLK}	—	ns
	ASP_BCLK frequency	f _{BCLK}	1.024	24.576	MHz
	ASP_BCLK high period	t _{HI:BCLK}	18	—	ns
	ASP_BCLK low period	t _{LO:BCLK}	18	—	ns
	ASP_FSYNC setup time before ASP_BCLK latching edge	t _{SU:FSYNC}	5	—	ns
	ASP_FSYNC hold time after ASP_BCLK latching edge	t _{H:FSYNC}	5	—	ns
	ASP_DIN setup time before ASP_BCLK latching edge	t _{SU:DIN}	10	—	ns
	ASP_DIN hold time after ASP_BCLK latching	t _{H:DIN}	5	—	ns
Primary Mode, VDD_IO1 = 3.3 V	ASP_FSYNC output sample/frame rate	F _s	16	384	kHz
	ASP_BCLK frequency	f _{BCLK}	2.8224	24.576	MHz
	ASP_BCLK duty cycle	D _{BCLK}	45	55	%
	ASP_FSYNC delay time after ASP_BCLK launching edge	t _{D:BCLK-FSYNC}	0	20	ns
	ASP_DIN setup time before ASP_BCLK latching edge	t _{SU:DIN}	6	—	ns
	ASP_DIN hold time after ASP_BCLK latching edge	t _{H:DIN}	5	—	ns
	ASP_DIN load capacitance	ASP_BCLK ASP_FSYNC	—	0	50
			0	50	pF
Secondary Mode, VDD_IO1 = 1.8 V	ASP_FSYNC input sample/frame rate	F _s	16	384	kHz
	ASP_FSYNC pulse width	t _{HI:FSYNC}	1/f _{ASP_BCLK}	—	ns
	ASP_BCLK frequency	f _{BCLK}	1.024	24.576	MHz
	ASP_BCLK high period	t _{HI:BCLK}	18	—	ns
	ASP_BCLK low period	t _{LO:BCLK}	18	—	ns
	ASP_FSYNC setup time before ASP_BCLK latching edge	t _{SU:FSYNC}	5	—	ns
	ASP_FSYNC hold time after ASP_BCLK latching edge	t _{H:FSYNC}	5	—	ns
	ASP_DIN setup time before ASP_BCLK latching edge	t _{SU:DIN}	10	—	ns
	ASP_DIN hold time after ASP_BCLK latching	t _{H:DIN}	5	—	ns

Table 3-11. Switching Specifications—Audio Serial Port (ASP) (Cont.)

Test conditions (unless specified otherwise): VDD_A = VDD_IO2 = 3.3 V; Ground = GND = GND_A = PAD = GND_D = 0 V; voltages are with respect to ground; input timings are measured at V_{IL} and V_{IH} thresholds, output timings are measured at V_{OL} and V_{OH} thresholds for VDD_IO1 logic (as specified in Table 3-8); T_A = 25°C.

Parameter 1,2		Symbol	Minimum	Maximum	Unit
Primary Mode, VDD_IO1 = 1.8 V	ASP_FSYNC output sample/frame rate	F _s	16	384	kHz
	ASP_BCLK frequency	f _{BCLK}	2.8224	24.576	MHz
	ASP_BCLK duty cycle	D _{BCLK}	45	55	%
	ASP_FSYNC delay time after ASP_BCLK launching edge	t _{D:BCLK-FSYNC}	0	20	ns
	ASP_DIN setup time before ASP_BCLK latching edge	t _{SU:DIN}	6	—	ns
	ASP_DIN hold time after ASP_BCLK latching edge	t _{H:DIN}	5	—	ns
	ASP_DIN load capacitance	ASP_BCLK ASP_FSYNC	—	0	50
			0	50	pF

1. ASP timing in I2S and Left-Justified Modes.
 ASP_BCLK can be inverted if required; the figure shows the default polarity.

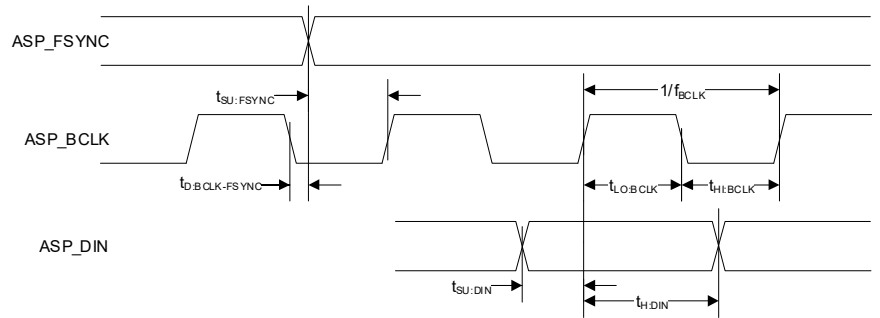

2. ASP timing in TDM Mode.
 ASP_BCLK can be inverted if required; the figure shows the default polarity.

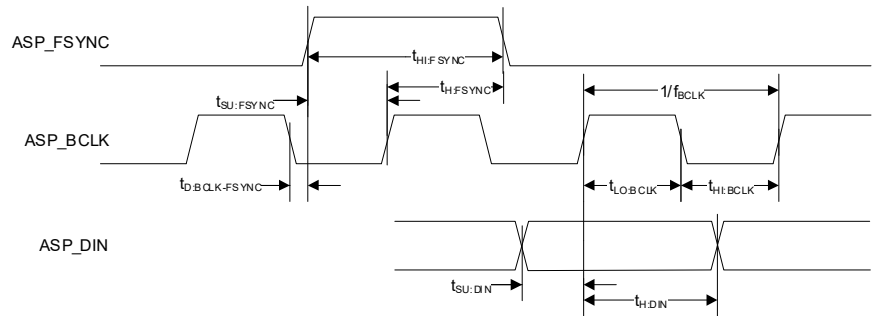

Table 3-12. Switching Specifications—I²C Control Port

Test conditions (unless specified otherwise): VDD_A = VDD_IO1 = VDD_IO2 = 3.3 V; Ground = GND = GND_A = PAD = GND_D = 0 V; voltages are with respect to ground; input timings are measured at V_{IL} and V_{IH} thresholds, output timings are measured at V_{OL} and V_{OH} thresholds for VDD_IO1 logic (as specified in Table 3-8); T_A = 25°C.

Parameter ^{1,2}	Symbol	Minimum	Maximum	Unit
SCL clock frequency	f _{SCL}	—	1000	kHz
Clock low time	t _{LOW}	500	—	ns
Clock high time	t _{HIGH}	260	—	ns
Start condition hold time (before first clock pulse)	t _{HDST}	260	—	ns
Setup time for repeated start	t _{SUST}	260	—	ns
Rise time of SCL and SDA	f _{SCL} ≤ 100 kHz	600	1000	ns
	100 kHz < f _{SCL} ≤ 400 kHz	180	300	ns
	400 kHz < f _{SCL} ≤ 1000 kHz	72	120	ns
Fall time of SCL and SDA	f _{SCL} ≤ 100 kHz	6.5	300	ns
	100 kHz < f _{SCL} ≤ 400 kHz	6.5	300	ns
	400 kHz < f _{SCL} ≤ 1000 kHz	6.5	120	ns
Rise time variation between SDA and SCL	—	—	1.67	ns
Fall time variation between SDA and SCL	f _{SCL} ≤ 100 kHz	—	100	ns
	100 kHz < f _{SCL} ≤ 400 kHz	—	100	ns
	400 kHz < f _{SCL} ≤ 1000 kHz	—	75	ns
Setup time for stop condition	t _{SUSP}	260	—	ns
SDA setup time to SCL rising	t _{SUD}	50	—	ns
SDA input hold time from SCL falling ³	t _{HDDI}	0	—	ns
Output data valid (Data/ACK) ⁴	f _{SCL} ≤ 100 kHz	—	3450	ns
	100 kHz < f _{SCL} ≤ 400 kHz	—	900	ns
	400 kHz < f _{SCL} ≤ 1000 kHz	—	450	ns
Bus free time between transmissions	t _{BUF}	500	—	ns
SDA bus capacitance	C _B	—	550	pF
SCL/SDA pull-up resistance	R _P	500	—	Ω
Pulse width of spikes to be suppressed	t _{ps}	0	50	ns

1. All timing is relative to thresholds specified in Table 3-8, V_{IL} and V_{IH} for input signals, and V_{OL} and V_{OH} for output signals.

2. I²C control-port timing.

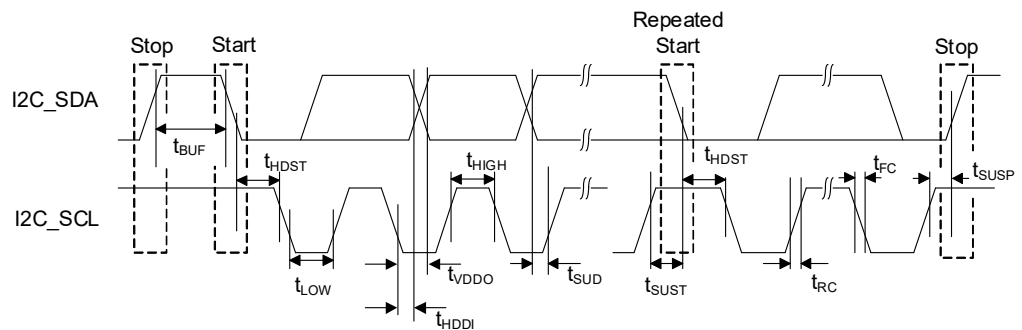

3. Data must be held long enough to bridge the transition time, t_{FC}, of SCL.

4. Time from falling edge of SCL until data output is valid.

Table 3-13. Switching Specifications—SPI Control Port

Test conditions (unless specified otherwise): VDD_A = VDD_IO = 3.3 V; Ground = GND = GND_A = PAD = GND_D = 0 V; voltages are with respect to ground; input timings are measured at V_{IL} and V_{IH} thresholds, output timings are measured at V_{OL} and V_{OH} thresholds for VDD_IO1 logic (as specified in Table 3-8); T_A = 25°C.

Parameter ¹	Symbol	Minimum	Maximum	Unit
SPI_SCK frequency	f _{SCY}	—	24	MHz
SPI_CS falling edge to SPI_SCK rising edge	t _{SSU}	5	—	ns
SPI_SCK falling edge to SPI_CS rising edge	t _{SHO}	0.5	—	ns
SPI_SCK pulse width low	t _{SCL}	18.5	—	ns
SPI_SCK pulse width high	t _{SCH}	18.5	—	ns
SPI_SDI to SPI_SCK setup time	t _{DSU}	5	—	ns
SPI_SDI to SPI_SCK hold time	t _{DHO}	2.5	—	ns
SPI_SCK falling edge to SPI_SDO transition	t _{DL}	0	15	ns
SPI_CS rising edge to SPI_SDO output high-Z	—	0	15	ns
Bus free time between active SPI_CS	t _{SH}	20	—	ns

1. SPI control-port timing.

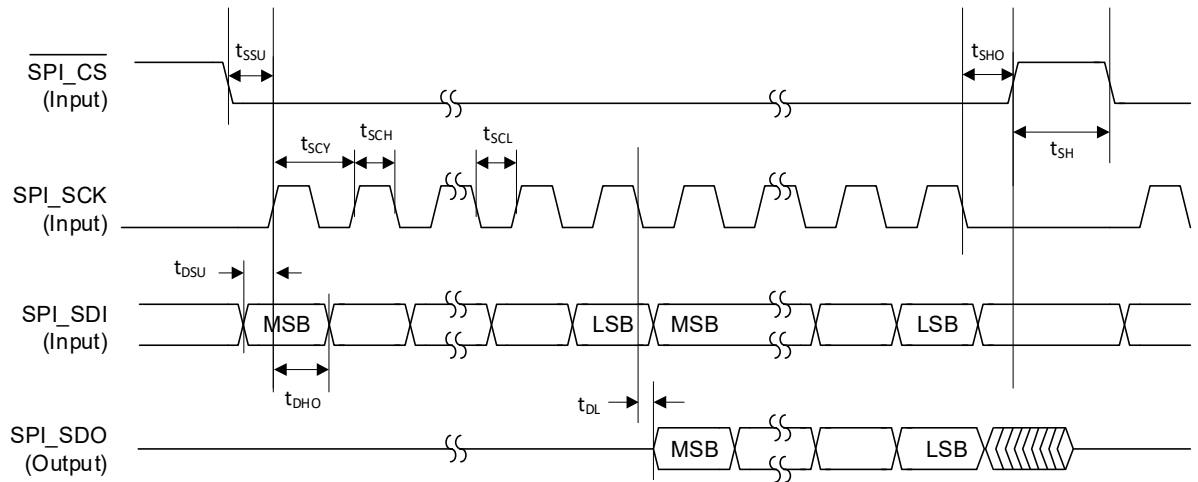

4 Functional Description

4.1 Device Power and Reset

The CS4332B is powered using VDD_A1, VDD_A2, VDD_IO1, and VDD_IO2 external supplies.

Notes: The VDD_A1 and VDD_A2 rails should be tied together and powered from a single supply. The associated power domain is referred to as VDD_A.

VDD_IO1 and VDD_IO2 are independent power domains. VDD_IO1 supplies host-related interfaces (e.g., SPI control interface); VDD_IO2 supplies external interfaces (e.g., crystal oscillator connections). Integrated level shifters are included for direct interface to logic levels from 1.8 V to 3.3 V.

There are no power-sequencing requirements—supplies can be enabled in any order.

The CS4332B is in reset if the $\overline{\text{RESET}}$ pin is asserted (Logic 0), or if the VDD_A supply is below the respective reset threshold defined in [Table 3-9](#).

All ground pins, including the ground paddle, must be tied to a common ground (GND) plane directly underneath the CS4332B.

4.2 Hardware Configuration

The CS4332B supports hardware and software control modes. In hardware mode, the device configuration is determined entirely by external resistors connected to the hardware-control pins. In software mode, the I²C/SPI control port is used to configure the device.

In hardware mode, the audio serial port (ASP) configuration is selected using the CONFIG1 and CONFIG2 pins as described in [Table 4-1](#). See [Section 4.4](#) for more details of the sample-rate selection and [Section 4.6](#) for more details of the ASP operation.

Table 4-1. Hardware Control—ASP Configuration

Pin Name	Pin Configuration	Description	
CONFIG1	Pull-up to VDD_IO1	0 Ω	Software control mode (I ² C/SPI)
		4.7 kΩ	In I ² C Mode, the pull-up resistor is used to select the device address—see Section 4.7 .
		22 kΩ	In SPI Mode, it is recommended to use a 100 kΩ pull-up resistor.
		100 kΩ	
	Pull-down to GND_D	100 kΩ	ASP Primary Mode, 176.4 kHz, 192 kHz sample rate
		22 kΩ	ASP Primary Mode, 88.2 kHz, 96 kHz sample rate
		4.7 kΩ	ASP Primary Mode, 44.1 kHz, 48 kHz sample rate
		0 Ω	ASP Secondary Mode, autodetect sample rate
CONFIG2	Pull-up to VDD_IO1	0 Ω	ASP TDM Mode—minimum time slots ¹ , ASP_FSYNC_TYPE = pulse
		4.7 kΩ	ASP TDM Mode—maximum time slots ² , ASP_FSYNC_TYPE = pulse
		22 kΩ	—
		100 kΩ	ASP TDM Mode—minimum time slots ¹ , ASP_FSYNC_TYPE = square wave (50% duty cycle) ³
	Pull-down to GND_D	100 k	ASP TDM Mode—maximum time slots ² , ASP_FSYNC_TYPE = square wave (50% duty cycle) ³
		22 kΩ	—
		4.7 kΩ	ASP Left-Justified Mode
		0 Ω	ASP I ² S Mode

1. The ASP data format is configured to support two time slots; this is the minimum necessary for the CS4332B input.

2. The ASP data format is configured to support the maximum number of time slots for the applicable BCLK rate, refer to [Table 4-8](#).

3. ASP_FSYNC_TYPE = square wave (50% duty cycle) is available in ASP Primary Mode only, as described in [Section 4.6](#).

If the ASP is configured for TDM data format with maximum time slots, the TDM slot selection is determined using the CONFIG3 pin as described in Table 4-2. See Section 4.6 for more details of the ASP TDM modes.

Table 4-2. Hardware Control—TDM Slot Selection

Pin Name	Pin Configuration		Description
CONFIG3	Pull-up to VDD_IO1	0 Ω	Slots 14–15 [1]
		4.7 kΩ	Slots 12–13 [1]
		22 kΩ	Slots 10–11 [1]
		100 kΩ	Slots 8–9 [1]
	Pull-down to GND_D	100 kΩ	Slots 6–7 [2]
		22 kΩ	Slots 4–5 [2]
		4.7 kΩ	Slots 2–3
		0 Ω	Slots 0–1

1. Slots 8–15 are only valid in 16-slot TDM Mode.

2. Slots 4–7 are only valid in 8-slot or 16-slot TDM Mode.

The clock-reference configuration is determined using the CONFIG4 pin as described in Table 4-3. See Section 4.4 for more details of the CS4332B clocking architecture

Table 4-3. Hardware Control—Clocking Configuration

Pin Name	Pin Configuration		Clock Reference	Reference Clock Frequency (MHz) ¹
CONFIG4	Pull-up to VDD_IO1	0 Ω	XTAL	1024 fs(base)
		4.7 kΩ	XTAL	512 fs(base)
		22 kΩ	MCLK	1024 fs(base)
		100 kΩ	MCLK	512 fs(base)

1. fs(base) is the base sample rate. fs(base) = 48 kHz for 48 kHz-related sample rates; or 44.1 kHz for 44.1 kHz-related sample rates.

In hardware mode, the device configuration is latched when reset is released (either power-on reset or deassertion of the $\overline{\text{RESET}}$ pin). In hardware mode, the configuration cannot be changed while the device is operational. To update the device configuration, the $\overline{\text{RESET}}$ pin must be asserted (Logic 0), or the device power cycled, in order to read new settings on the CONFIGx pins.

If software mode is selected (i.e., CONFIG1 is pulled-up to VDD_IO1), the device configuration is controlled by register writes via the applicable control interface, as described in Section 4.7. Unused CONFIGx pins should be terminated as described in Section 1.3.

Note: In software mode, the CONFIG1 pin is used to select the I²C target address (see Section 4.7). If the SPI control interface is used, it is recommended to connect the CONFIG1 pin to VDD_IO1 via a 100 kΩ resistor.

4.3 Software Configuration

Software control mode is enabled if the CONFIG1 pin is pulled-up to VDD_IO1; note that $\overline{\text{RESET}}$ must remain asserted (i.e., Logic_0) until CONFIG_1/SPI_CS is deasserted (i.e., Logic_1). In software control mode, the CS4332B is configured by writing to control registers using the control port.

The control port supports I²C and SPI modes of operation; the applicable mode is detected automatically on the respective interface pins. In I²C mode, the target address is selectable using the CONFIG1 pin. See Section 4.7 for further details of the I²C/SPI control port.

In software control mode, GLOBAL_EN is used as the global control field for enabling/disabling the CS4332B functions. The device should be configured using the applicable control registers before setting GLOBAL_EN.

Notes: The clocking (Section 4.4) and ASP (Section 4.6) control registers are only valid on the rising edge of GLOBAL_EN. Writing to these registers has no effect at any other time. It is recommended to select the disabled state (GLOBAL_EN = 0) before writing to these registers.

To minimize the CS4332B power consumption when all output paths are disabled, see Section 4.5.4.

A reset of the CS4332B can be triggered by writing 0x5A to the `SW_RESET` field. A software reset disables all functions and sets the control registers to their default states.

4.4 System Clocking

Clocking for the CS4332B is provided using either the MCLK input or the crystal oscillator. In each case, the frequency must be 1024 fs(base) or 512 fs(base); where fs(base) = 48 kHz (for 48 kHz-related sample rates), or 44.1 kHz (for 44.1 kHz-related sample rates). The specifications for the clocking sources are described in [Table 3-10](#); for optimal out-of-band noise performance a system clock rate of 1024 fs(base) is recommended.

In hardware mode, the clock source is configured using the CONFIG4 pin, as detailed in [Table 4-3](#). In software mode, the clocking source is selected using `SYSCLK_SRC`.

The crystal oscillator uses an external crystal (XTAL) to generate the system clock. Load capacitors are connected to the crystal as shown in [Fig. 4-1](#). A series resistor (R_S) may also be required to configure the drive level for the selected crystal.

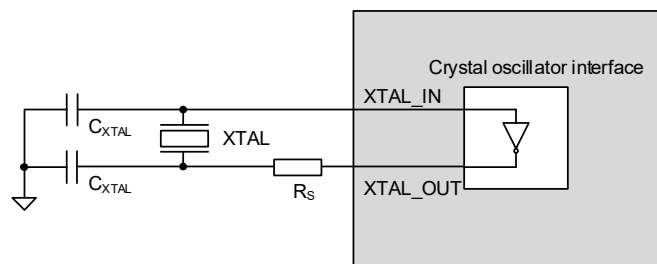

Figure 4-1. Crystal Oscillator Connection

Guidance on selecting a suitable crystal and associated components is provided in [Section 5.2](#). The suitability of the external crystal is calculated as a function of the operating voltage (V_{DD_IO2}) and the transconductance of the crystal interface, as defined in [Table 3-10](#).

If clocking is provided using the crystal oscillator, the CS4332B outputs a clock on the MCLK pin. The frequency of the MCLK output clock matches the crystal oscillator frequency. The output clock can be used to drive other devices.

In ASP Secondary Mode, the ASP_FSYNC input is used to control the DAC-conversion timing, enabling multiple CS4332B devices to operate synchronously (sample timing is phase aligned) in a system. The external clocks ASP_FSYNC and ASP_BCLK must be derived from a common clock source (i.e., the MCLK input, or the MCLK output when clocking is provided using the crystal oscillator). See [Section 4.6](#) for more details of the ASP.

The clocking architecture is illustrated in Fig. 4-2.

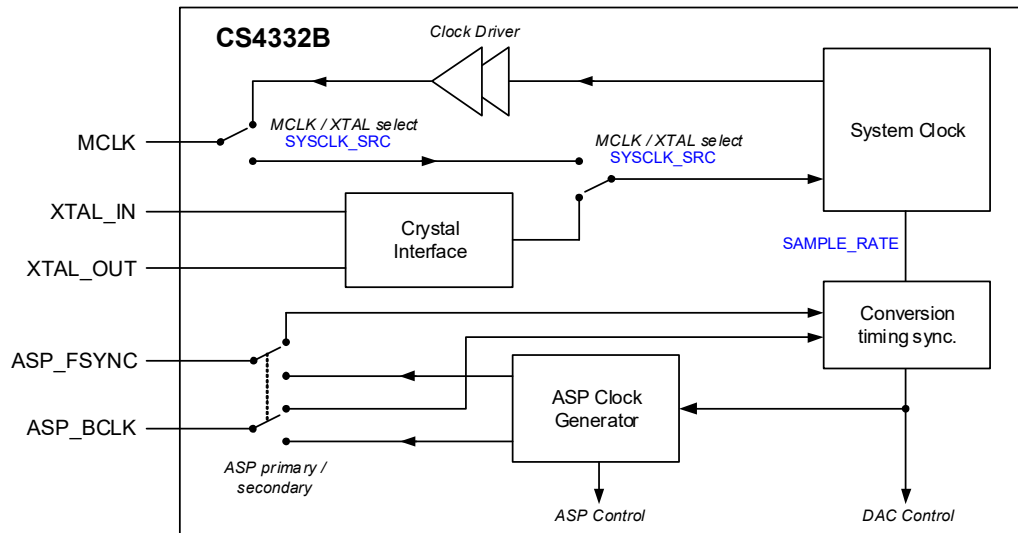

Figure 4-2. System Clocking

4.4.1 Hardware Control Mode

In hardware control mode, the system clock can be sourced from the MCLK pin or from the crystal oscillator. In each case, the frequency must be 1024 fs(base) or 512 fs(base); where fs(base) = 48 kHz (for 48 kHz-related sample rates), or 44.1 kHz (for 44.1 kHz-related sample rates). The clock source is configured using the CONFIG4 pin as described in Section 4.2.

The sample rate is selected using the CONFIG1 pin as described in Section 4.2. Sample rates 44.1 kHz–192 kHz can be configured, or else the autodetect option (sample rates 16 kHz–192 kHz) automatically configures the device according to the ASP interface clock signals. The autodetect sample-rate option is only valid if the ASP is operating in Secondary Mode (see Section 4.6).

The supported clocking configurations are summarized in Table 4-4.

Table 4-4. System Clock Configuration

Reference Source	Reference Frequency (MHz)	ASP Operating Conditions ¹
MCLK or XTAL	24.576 or 49.152	Primary or Secondary Mode, I ² S, left-justified, or TDM data formats, sample rates 48, 96, and 192 kHz Primary Mode, or sample rates 16, 32, 48, 96, and 192 kHz in Secondary Mode (autodetect only).
MCLK or XTAL	22.5792 or 45.1584	Primary or Secondary Mode, I ² S, left-justified, or TDM data formats, sample rates 44.1, 88.2, 176.4 kHz in Primary Mode, or sample rates 44.1, 88.2, 176.4 kHz in Secondary Mode (autodetect only).

1. See Section 4.6 for details of the audio serial port (ASP).

The sample rate must be related to the system clock reference as described in Table 4-5.

Table 4-5. Hardware Control Mode Sample Rate Options

Reference Source	Reference Frequency (MHz)	MCLK Out (MHz)	Sample Rate (kHz)
MCLK	22.5792 or 45.1584	—	44.1, 88.2, 176.4
	24.576 or 49.152		16, 32, 48, 96, 192
XTAL	22.5792 or 45.1584	22.5792 or 45.1584	44.1, 88.2, 176.4
	24.576 or 49.152	24.576 or 49.152	16, 32, 48, 96, 192

If the ASP is configured in ASP Secondary Mode, the external clocks (MCLK, BCLK, and FSYNC) must be derived from a common clock source. The clocks must be synchronized, but the phase difference is not important. If clocking for the CS4332B is provided using the crystal oscillator, then the BCLK and FSYNC signals should be derived from the common clock source provided by the CS4332B MCLK output, see [Section 4.6](#).

4.4.2 Software Control Mode

In software (I²C/SPI) control mode, the clocking configuration is selected using the following control fields:

- The sample rate is configured using [SAMPLE_RATE](#). Sample rates 16 kHz–384 kHz can be configured, or else the autodetect option automatically configures the device according to the ASP interface signals. The sample-rate autodetect option is only valid for sample rates 16 kHz–192 kHz.
- The system clock source is selected using [SYSCLK_SRC](#). The clock source can be either the crystal oscillator or MCLK.
- The system clock frequency is configured using [SYSCLK_FREQ](#). The system clock frequency must be 1024 fs(base) or 512 fs(base); where fs(base) = 48 kHz (for 48 kHz-related sample rates), or 44.1 kHz (for 44.1 kHz-related sample rates).

The sample rate must be related to the system clock reference as described in [Table 4-6](#).

Table 4-6. Software Control Mode Sample Rate Options

Reference Source	Reference Frequency (MHz)	MCLK Out (MHz)	Sample Rate (kHz)
MCLK	22.5792 or 45.1584	—	44.1, 88.2, 176.4, 352.8
	24.576 or 49.152		16, 32, 48, 96, 192, 384
XTAL	22.5792 or 45.1584	22.5792 or 45.1584	44.1, 88.2, 176.4, 352.8
	24.576 or 49.152	24.576 or 49.152	16, 32, 48, 96, 192, 384

The sample-rate autodetect option (16 kHz–192 kHz) is only valid if the ASP is operating in Secondary Mode (see [Section 4.6](#)).

If the ASP is configured in ASP Secondary Mode, the external clocks (MCLK, BCLK, and FSYNC) must be derived from a common clock source. The clocks must be synchronized, but the phase difference is not important. If clocking for the CS4332B is provided using the crystal oscillator, then the BCLK and FSYNC signals should be derived from the common clock source provided by the CS4332B MCLK output, see [Section 4.6](#).

4.5 DAC and Analog Output

The CS4332B supports up to two analog output channels, each incorporating a high-performance sigma-delta digital-to-analog converter (DAC). Digital volume and mute control is provided on each output channel.

The digital volume and mute controls are supported in software (I²C/SPI) control mode only. In hardware control mode, all channels are enabled with 0 dB volume.

4.5.1 Path Enable

The analog outputs and DAC paths are enabled using [OUTx_DAC_EN](#) (where x indicates the channel number 1–2).

When the output paths are enabled for the first time after power-up or after the DAC reference has been disabled (described in [Section 4.5.4](#)), the paths do not become active until a startup delay has elapsed; the delay ensures the noise floor of the output path has settled before it becomes active and mitigates any audible artifacts. The time delay (1 s) is applied when the output paths are enabled using [OUTx_DAC_EN](#).

The polarity of the DAC output can be inverted using [OUTx_INV](#) for the respective channel.

The CS4332B supports a mono output configuration; this can be used in applications where stereo sound is unnecessary, such as voice playback, alarms, or devices with a single speaker. If mono operation is required, it is recommended to configure the CS4332B with a single output path enabled prior to initial startup to minimize any audible artifacts.

4.5.2 Digital Volume and Mute

The signal path incorporates a digital volume control, supporting a gain range of -127.5 dB to 0 dB in 0.5 dB steps. Volume ramping and digital mute is also supported.

The digital volume is configured using `OUTx_VOL` for the respective output channel. The digital mute is enabled by setting `OUTx_MUTE`.

Writing to the volume or mute fields has no effect on the signal path until a 1 is written to `OUT_VU`. Writing 1 to `OUT_VU` causes the volume and mute settings to be updated on all output paths simultaneously.

When the volume or mute is changed, the gain of the affected signal paths is ramped up or down to the new setting. For increasing gain, the rate is controlled by `OUT_RAMP_RATE_INC`; for decreasing gain, the rate is controlled by `OUT_RAMP_RATE_DEC`.

Note: The `OUT_RAMP_RATE_INC` and `OUT_RAMP_RATE_DEC` fields should not be changed while a volume ramp is in progress.

4.5.3 Power Optimization

A Class A amplifier is provided in the output path to convert the current output to a voltage output. An external feedback circuit is required, as described in [Section 5.1](#).

A voltage output of $2 V_{RMS}$ is provided; this supports a minimum resistive load of 3 k Ω in parallel with a maximum capacitive load of 100 pF. If the load has a higher-impedance, the CS4332B can optimize power consumption by adjusting the drive current while maintaining an output of $2 V_{RMS}$. In this case, a minimum resistive load of 10 k Ω in parallel with a maximum capacitive load of 100 pF is supported.

The maximum load impedance is selected using `OUT_LOAD_CFG`.

4.5.4 DAC Shutdown

To minimize power consumption when all output paths are disabled, the DAC reference circuit can be disabled. Note that power consumption is only reduced if the output paths have previously been enabled. Until they are enabled for the first time, the power consumption is already minimized.

In software mode, the DAC reference circuit is disabled using `DAC_SHUTDOWN`. If this bit is set, all paths are disabled regardless of the status of the `OUTx_DAC_EN` bits. Prior to disabling the DAC reference circuit, it is recommended to mute the output paths, as described in [Section 4.5.2](#).

Note: If the `DAC_SHUTDOWN` bit is cleared, any output paths where `OUTx_DAC_EN` is set are enabled.

In hardware mode, the DAC shutdown function incorporates a controlled shutdown sequence to mitigate any audible artifacts. The shutdown sequence slowly ramps down the digital volume and then ramps down the DAC output voltage prior to disabling the DAC reference circuit.

The shutdown sequence is selected using a rising-edge logic input on the GPIO1 pin. GPIO1 must be held low (i.e., Logic 0) during device startup.

To enable the DAC reference circuit after a hardware shutdown, the `RESET` pin must be asserted (Logic 0), or the device power cycled.

4.6 Audio Serial Port (ASP)

The multichannel ASP supports the input of digital audio samples to the CS4332B. The ASP can be configured as a primary or secondary interface, and supports I²S, left-justified, and TDM data formats.

In hardware control mode, the ASP data format is determined by the CONFIG1 and CONFIG2 pins (see [Section 4.2](#)). In software (I²C/SPI) control mode, the ASP data format is configured using register fields.

In hardware mode, sample rates 16 kHz–192 kHz are supported (sample rates 16 kHz and 32 kHz are supported using autodetect in ASP Secondary Mode only). In software mode, sample rates 16 kHz–384 kHz are supported; sample rate 384 kHz is not supported by autodetect. The supported sample rates in ASP Primary Mode and ASP Secondary Mode are summarized in [Table 4-7](#).

Table 4-7. Supported Sample Rates in ASP Primary Mode and ASP Secondary Mode

Sample Rate (kHz)	ASP Primary Mode		ASP Secondary Mode	
	Hardware Control Mode	Software Control Mode	Hardware Control Mode	Software Control Mode
16–32	—	Configurable using SAMPLE_RATE	Determined using autodetect only	Configurable using SAMPLE_RATE (autodetect available)
44.1–192	Determined by CONFIG1 pin			Configurable using SAMPLE_RATE (autodetect not available)
352.8, 384	—		—	Configurable using SAMPLE_RATE (autodetect not available)

4.6.1 Primary and Secondary Operation

The ASP interface can operate as a primary or secondary interface. In the primary configuration, the BCLK and FSYNC signals are generated by the CS4332B. In the secondary configuration, the BCLK and FSYNC pins are inputs, allowing another device to drive the respective signals.

In ASP Secondary Mode, the external clocks (MCLK, BCLK, and FSYNC) must be derived from a common clock source. The clocks must be synchronized, but the phase difference is not important.

If clocking is provided by the crystal oscillator and the CS4332B is operating in ASP Secondary Mode, then the FSYNC and the BCLK signals should be derived from the common clock source provided by the CS4332B MCLK output.

In hardware control mode, the ASP is configured as a primary or secondary interface using the CONFIG1 pin (see [Section 4.2](#)). In software control mode, the ASP primary/secondary configuration is selected using [ASP_PRIMARY](#).

The ASP operation as a primary or secondary interface with MCLK as the clocking source is illustrated in [Fig. 4-3](#) and [Fig. 4-4](#).

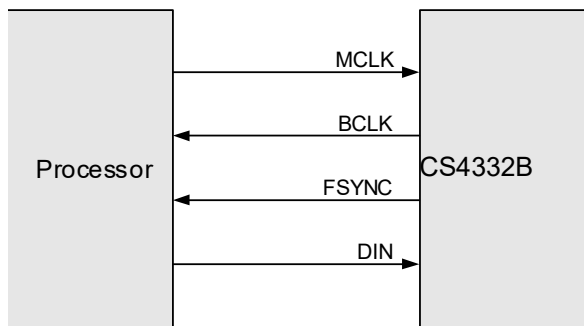

Figure 4-3. Primary Mode, MCLK Clocking Source

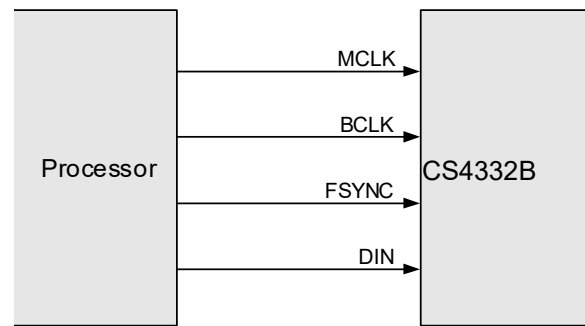

Figure 4-4. Secondary Mode, MCLK Clocking Source

The ASP operation as a primary or secondary interface with a crystal as the clocking source is illustrated in Fig. 4-5 and Fig. 4-6.

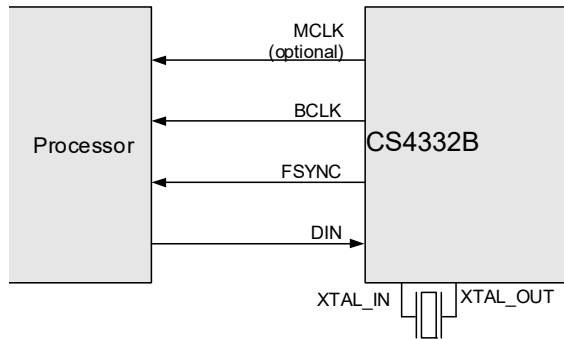

Figure 4-5. Primary Mode, XTAL Clocking Source

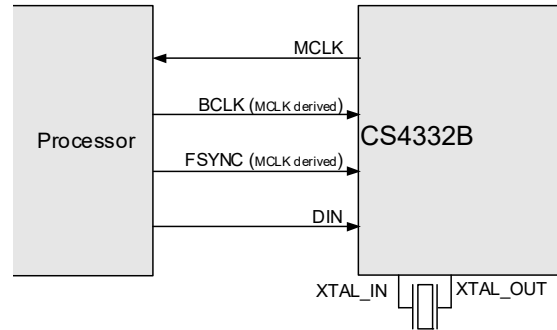

Figure 4-6. Secondary Mode, XTAL Clocking Source

4.6.2 ASP Data Formats

The ASP interface can be configured to operate in I²S, left-justified, or TDM data formats as illustrated in Fig. 4-7 through Fig. 4-9. The data-bit order is MSB first in each case; data words are encoded in 2's complement (signed, fixed-point) format. Each audio sample is allocated a time slot within the FSYNC frame.

- In I²S Mode, the MSB is valid on the second BCLK rising edge following an FSYNC transition. The other bits up to the LSB are valid on each successive BCLK cycle. Depending on word length, BCLK frequency, and sample rate, there may be unused BCLK cycles between the LSB of one sample and the MSB of the next.

I²S Mode data format is shown in Fig. 4-7.

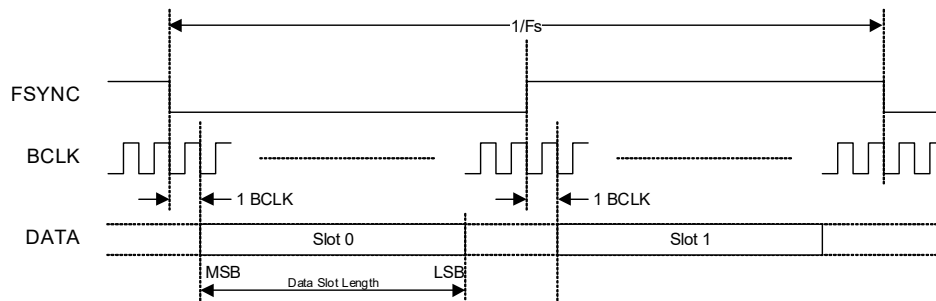

Figure 4-7. I²S Data Format

- In Left-Justified Mode, the MSB is valid on the first BCLK rising edge following an FSYNC transition. The other bits up to the LSB are valid on each successive BCLK cycle. Depending on word length, BCLK frequency, and sample rate, there may be unused BCLK cycles between the LSB of one sample and the MSB of the next.

Left-Justified Mode data format is shown in Fig. 4-8.

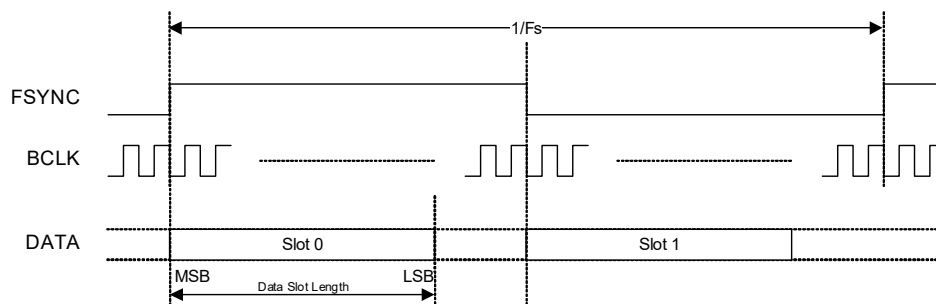

Figure 4-8. Left-Justified Data Format

- In TDM Mode, if the ASP is configured in Secondary Mode, the MSB of the first channel is valid on the second BCLK rising edge following a rising FSYNC edge. The other bits up to the LSB are valid on each successive BCLK cycle. If the ASP is configured in Primary Mode, the FSYNC signal can be configured as a pulse (default) or a square wave (with a 50% duty cycle). If the FSYNC signal is configured as a pulse, the MSB of the first channel is valid on the second BCLK rising edge following a rising FSYNC edge. The other bits up to the LSB are valid on each successive BCLK cycle.

In ASP Secondary Mode and in ASP Primary Mode with the FSYNC signal configured as a pulse, the subsequent channels follow immediately after the first channel. The pulse duration can be anything less than $1/F_s$, provided the falling edge of the frame pulse occurs at least one BCLK period before the rising edge of the next frame pulse. Depending on word length, BCLK frequency, and sample rate, there may be unused BCLK cycles between the LSB of one sample and the MSB of the next.

TDM Mode data format in ASP Secondary Mode and ASP Primary Mode with FSYNC configured as a pulse is shown in Fig. 4-9.

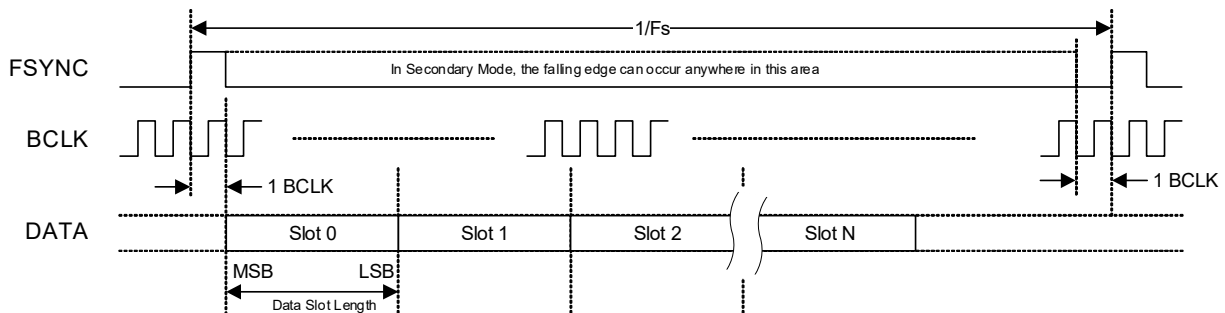

Figure 4-9. TDM Data Format Primary Mode (FSYNC = Pulse) and Secondary Mode

In ASP Primary Mode with the FSYNC signal configured as a square wave, the slots are aligned with both rising and falling edges of FSYNC and half of the available slots occur within each phase of the FSYNC cycle. The total number of available slots is determined by the sample rate, as described in Table 4-8.

- The MSB of the first channel in each phase of the FSYNC cycle is valid on the second BCLK rising edge following the rising and falling FSYNC edge respectively. The other bits up to the LSB are valid on each successive BCLK cycle. Depending on word length, BCLK frequency, sample rate, and number of available slots, there may be unused BCLK cycles between the LSB of one sample and the MSB of the next.

TDM Mode data format in ASP Primary Mode with FSYNC configured as a square wave is shown in Fig. 4-10.

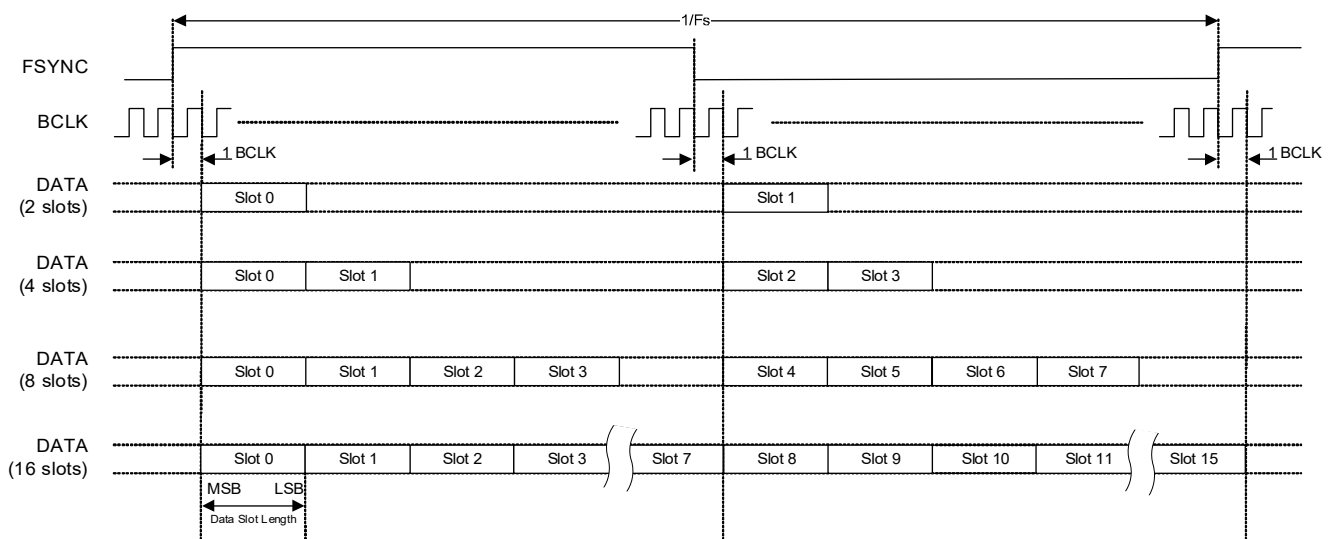

Figure 4-10. TDM Data Format Primary Mode (FSYNC = Square Wave)

4.6.3 ASP Configuration

In hardware control mode, the ASP data format is determined by the CONFIG1 and CONFIG2 pins (see [Section 4.2](#)).

In software control mode, the ASP data format is configured using [SAMPLE_RATE](#), and [ASP_FORMAT](#). If ASP Primary Mode is selected (see [Section 4.6.1](#)), the BCLK frequency is configured using [ASP_BCLK_FREQ](#) and the FSYNC waveform type (pulse or square wave) is configured using [ASP_FSYNC_TYPE](#).

In software control mode, the BCLK polarity is selected using [ASP_BCLK_INV](#). The polarity selection is valid in Primary and Secondary Modes, and determines whether the data is valid for sampling on the rising edge or the falling edge.

The BCLK polarity is illustrated in [Fig. 4-11](#) and [Fig. 4-12](#). In hardware control mode, the BCLK polarity is assumed to be noninverted.

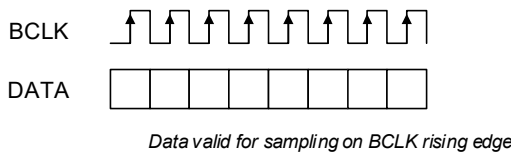

Figure 4-11. Noninverted BCLK

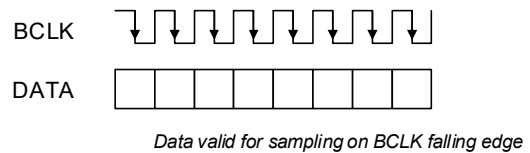

Figure 4-12. Inverted BCLK

In TDM Mode, the two data-format options are supported as follows:

- TDM Mode—minimum slots. The ASP data format is configured to support two slots. This mode allows the BCLK rate to be as low as possible, equating to a minimum of 128 BCLK cycles per audio sample at a minimum sample rate of 64 Fs.
- TDM Mode—maximum time slots. The ASP data format is configured to support the maximum number of time slots for the applicable BCLK rate. The mode is designed for the maximum BCLK rate (22.5792 MHz for 44.1 kHz-related sample rates, or 24.576 MHz for 48 kHz-related sample rates), enabling the maximum possible bandwidth on the ASP data bus to be shared with other devices.

The ASP configuration depends on the sample rate and the selected data format as described in [Table 4-8](#).

Table 4-8. ASP Data Format

ASP Format 1	ASP Sample Rate 2,3	Time Slots per Frame 4	BCLK Rate ^{5,6}
I ² S, Left-Justified	16 kHz	2	BCLK ≥ 64×Fs ^[7]
	32 kHz		BCLK ≥ 64×Fs ^[8]
	44.1 kHz, 48 kHz		BCLK ≥ 64×Fs
	88.2 kHz, 96 kHz		BCLK ≥ 64×Fs
	176.4 kHz, 192 kHz		BCLK ≥ 64×Fs
	352.8 kHz, 384 kHz		BCLK ≥ 64×Fs
	Autodetect (16 kHz–192 kHz)		BCLK ≥ 64×Fs
TDM—minimum time slots	16 kHz	2	BCLK ≥ 64×Fs ^[7]
	32 kHz		BCLK ≥ 64×Fs ^[8]
	44.1 kHz, 48 kHz		BCLK ≥ 64×Fs
	88.2 kHz, 96 kHz		BCLK ≥ 64×Fs
	176.4 kHz, 192 kHz		BCLK ≥ 64×Fs
	352.8 kHz, 384 kHz		BCLK ≥ 64×Fs
	Autodetect (16 kHz–192 kHz)		BCLK ≥ 64×Fs
TDM—maximum time slots	16 kHz	16	BCLK ≥ 512×Fs ^[7]
	32 kHz		BCLK ≥ 512×Fs ^[8]
	44.1 kHz, 48 kHz	8	BCLK = 512×Fs
	88.2 kHz, 96 kHz		BCLK = 256×Fs
	176.4 kHz, 192 kHz	4	BCLK = 128×Fs
	352.8 kHz, 384 kHz	2	BCLK = 64×Fs
	Autodetect (16 kHz–192 kHz)	4	BCLK ≥ 128×Fs

1. The ASP format is selected using the CONFIG2 pin (in hardware control mode) or [ASP_FORMAT](#) (in software control mode).

2. The sample rate is selected using the CONFIG1 pin (in hardware control mode) or [SAMPLE_RATE](#) (in software control mode).
3. Sample rates 16 kHz–192 kHz are supported in hardware and software control modes; sample rate 384 kHz is supported in software control mode only.
4. Time slots per frame is the number of data-sample time slots supported on the DIN pin.
5. The BCLK rate must be a constant integer multiple of the sample rate (F_s).
6. In ASP Primary Mode (hardware control), the BCLK frequency is the minimum specified rate. In ASP Primary Mode (software control), the BCLK frequency is configured using [ASP_BCLK_FREQ](#).
7. In ASP Primary Mode, the specified minimum BCLK frequency for 16 kHz sample rate is not supported. The available options correspond to $192 \times F_s$, $384 \times F_s$, $768 \times F_s$, or $1536 \times F_s$.
8. In ASP Primary Mode, the specified minimum BCLK frequency for 32 kHz sample rate is not supported. The available options correspond to $96 \times F_s$, $192 \times F_s$, $384 \times F_s$, or $768 \times F_s$.

The ASP data format in I²S, Left-Justified, and TDM interface modes as illustrated in [Fig. 4-13](#) through [Fig. 4-16](#). Refer to [Table 4-8](#) for the applicable definition.

- If I²S data format is selected, the ASP supports audio channels 1–2 as shown in [Fig. 4-13](#). The minimum BCLK rate is $64 \times F_s$ (where F_s is the sample rate). In ASP Primary Mode, the minimum BCLK rate of $64 \times F_s$ is not supported for sample rates of 16 kHz or 32 kHz. A higher BCLK frequency can be used, resulting in unused BCLK cycles between the LSB of one sample and the MSB of the next.

The input data is provided on ASP_DIN.

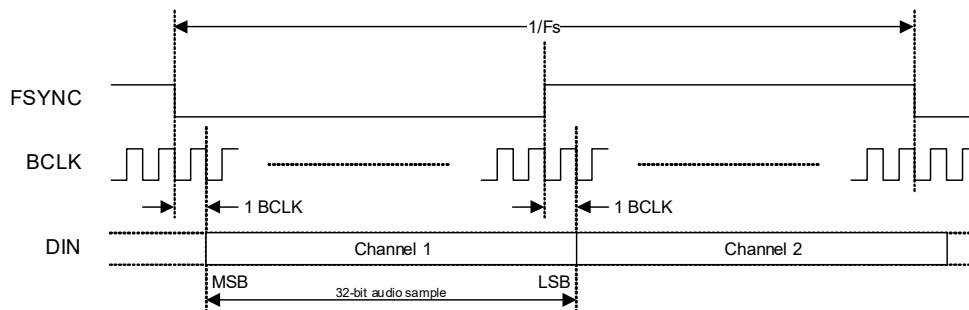

Figure 4-13. I²S Data Format

- If Left-Justified data format is selected, the ASP supports audio channels 1–2 as shown in [Fig. 4-14](#). The minimum BCLK rate is $64 \times F_s$ (where F_s is the sample rate). In ASP Primary Mode, the minimum BCLK rate of $64 \times F_s$ is not supported for sample rates of 16 kHz or 32 kHz. A higher BCLK frequency can be used, resulting in unused BCLK cycles between the LSB of one sample and the MSB of the next.

The input data is provided on ASP_DIN.

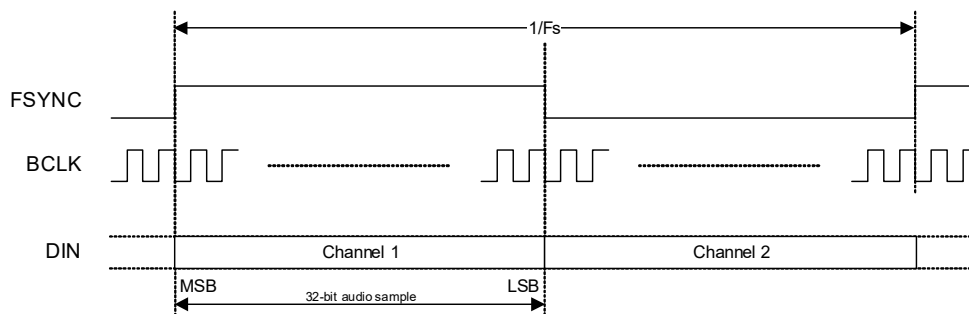

Figure 4-14. Left-Justified Data Format

- In TDM Mode, the FSYNC frame is configured for 2, 4, 8, or 16 slots as specified in [Table 4-8](#). In 4-, 8-, and 16-slot modes, the slot assignment for audio channels 1–2 is selected using the CONFIG3 pin (in hardware control mode—see [Section 4.2](#)) or else using [ASP_TDM_SLOT](#) (in software control mode). In 2-slot modes, the default slot assignment (slots 0–1) should be selected. The BCLK rate is related to the sample rate (F_s) as described in [Table 4-8](#). Where applicable, the BCLK rate can be higher than the stated minimum, resulting in additional unused BCLK cycles between the last slot in the frame and the start of the next frame.

The input data is provided on ASP_DIN.

An example of the 4-slot TDM format in ASP Secondary Mode and in ASP Primary Mode with the FSYNC signal configured as a pulse is shown in Fig. 4-15. In this example, audio channels 1–2 occupy TDM slots 0–1 respectively.

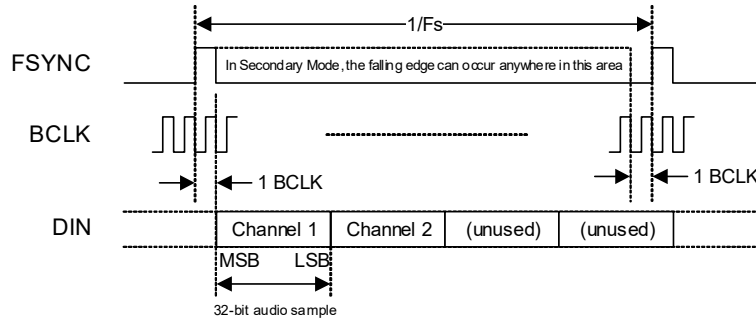

Figure 4-15. TDM Data Format, 4-Slot Example (FSYNC = Pulse)

An example of the 4-slot TDM format in ASP Primary Mode with the FSYNC signal configured as a square wave is shown in Fig. 4-16. In this example, audio channels 0 and 1 occupy TDM slots 0 and 1 in the high (Logic 1) phase of the FSYNC signal, TDM slot 0 and 1 in the low (Logic 1) phase of the FSYNC signal are unused.

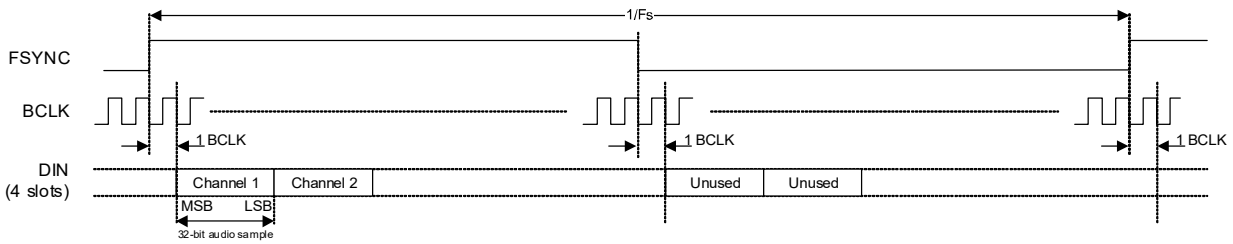

Figure 4-16. TDM Data Format, 4-Slot Example (FSYNC = Square Wave)

4.7 I²C/SPI Control Port

The CS4332B incorporates a control port, supporting I²C or SPI modes of operation; this is selected using CONFIG1, as described in Table 4-1. If the SPI control interface is required, it is recommended to use a pull-up resistor of 100 kΩ. In software control mode, the CS4332B is configured by writing to control registers using the control port.

The control port is automatically configured in I²C mode or SPI mode following the first valid I²C/SPI activity detected after power-on or hardware reset.

4.7.1 I²C Control Port

The I²C control port is supported using the following pins, which must be configured for the I²C function if required:

- CONFIG2/SPI_SDI/I2C_SDA
- CONFIG3/SPI_SDO/I2C_SCL

The CS4332B is a target device on the I²C bus—SCL is a clock input, while SDA is a bidirectional data pin. To allow arbitration of multiple targets (and/or multiple controllers) on the same interface, the CS4332B transmits Logic 1 by tristating the SDA pin, rather than pulling it high. An external pull-up resistor is required to pull the SDA line high so that the Logic 1 can be recognized by the controller.

In order to allow many devices to share a single two-wire control bus, every device on the bus has a unique 8-bit device address (this is not the same as the address of each register in the CS4332B). The LSB of the device address is the read/write bit; this bit is set to Logic 1 for read and Logic 0 for write.

The I²C device address is configured using the CONFIG1 pin as described in [Table 4-9](#).

Table 4-9. I²C Address Selection—CONFIG1 pin

Pin Configuration	I ² C Address	
Pull-up to VDD_IO1	0 kΩ	0x36 (write), 0x37 (read)
	4.7 kΩ	0x34 (write), 0x35 (read)
	22 kΩ	0x32 (write), 0x33 (read)
	100 kΩ	0x30 (write), 0x31 (read)

The host device indicates the start of data transfer with a high-to-low transition on SDA while SCL remains high. This indicates that a device address and subsequent address/data bytes follow. The CS4332B responds to the start condition and shifts in the next 8 bits on SDA (8-bit device address, including read/write bit, MSB first). If the device address received matches the device address of the CS4332B, the CS4332B responds by pulling SDA low on the next clock pulse (ACK). If the device address is not recognized or the R/W bit is set incorrectly, the CS4332B returns to the idle condition and waits for a new start condition.

If the device address matches the device address of the CS4332B, the data transfer continues. The controller indicates the end of data transfer with a low-to-high transition on SDA while SCL remains high. After receiving a complete address and data sequence the CS4332B returns to the idle state and waits for another start condition. If a start or stop condition is detected out of sequence at any point during data transfer (i.e., SDA changes while SCL is high), the device returns to the idle condition.

The I²C interface uses a 16-bit register address and 16-bit data words. The register address must be aligned to a 16-bit word boundary (i.e., the LSB must be 0). The full I²C message protocol also includes a device address, a read/write bit, and other signaling bits (see [Fig. 4-17](#) and [Fig. 4-18](#)).

The CS4332B supports the following read and write operations:

- Single write
- Single read
- Multiple write
- Multiple read

Continuous (multiple) read and write modes allow register operations to be scheduled faster than is possible with single register operations. In these modes, the CS4332B automatically increments the register address after each data word. Successive data words can be input/output every two data bytes.

The I²C protocol for a single, 16-bit register write operation is shown in [Fig. 4-17](#).

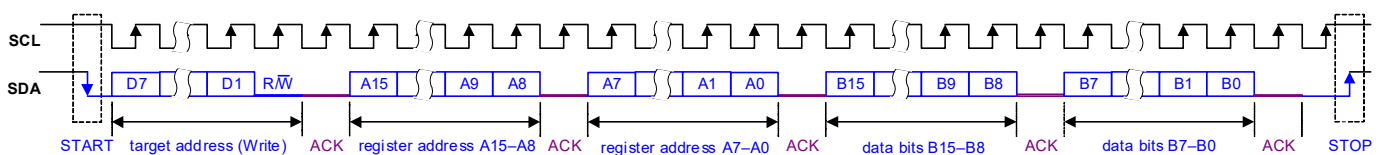

Note: The SDA pin is used as input for the control register address and data; SDA is pulled low by the receiving device to provide the acknowledge (ACK) response

Figure 4-17. Control Interface I²C Register Write

The I²C protocol for a single, 16-bit register read operation is shown in Fig. 4-18.

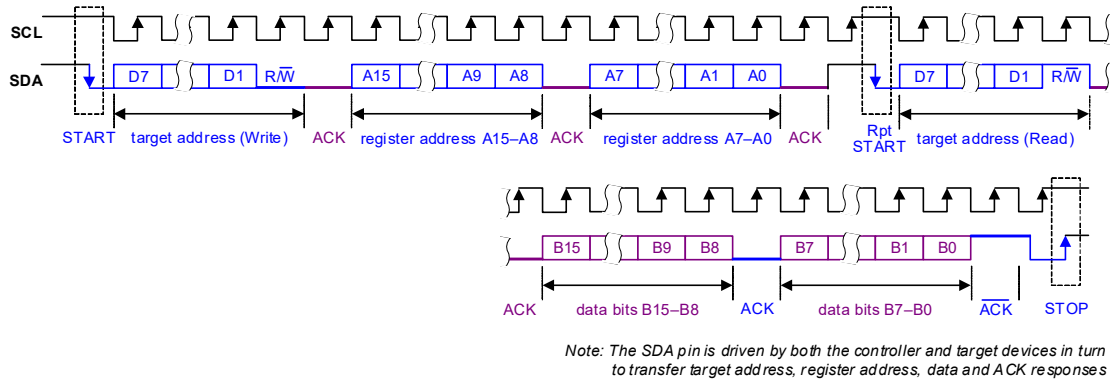

Figure 4-18. Control Interface I²C Register Read

The control interface also supports other register operations; the interface protocol for these operations is shown in Fig. 4-19 through Fig. 4-22. The terminology used in the following figures is detailed in Table 4-10.

Table 4-10. Control Interface (I²C) Terminology

Terminology	Description
S	Start condition
Sr	Repeated start
A	Acknowledge (SDA low)
\bar{A}	No Acknowledge (SDA high)
P	Stop condition
R/ \bar{W}	Read/not Write: 0 = Write, 1 = Read
[White field]	Data flow from bus controller to CS4332B
[Gray field]	Data from CS4332B to bus controller

Fig. 4-19 shows a single register write to a specified address.

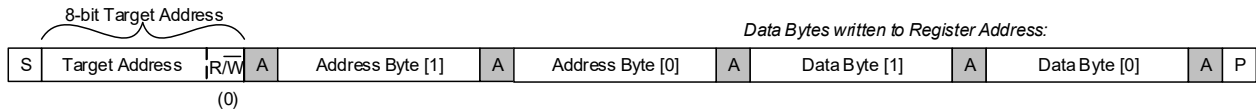

Figure 4-19. Single-Register Write to Specified Address

Fig. 4-20 shows a single register read from a specified address.

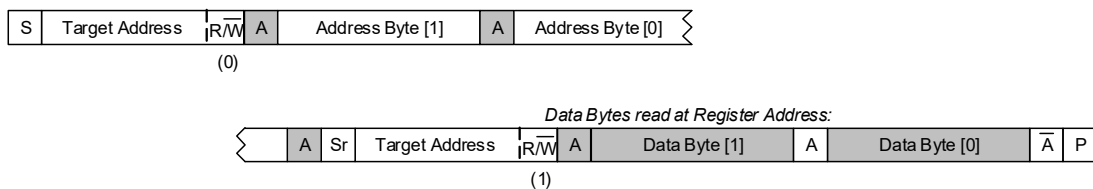

Figure 4-20. Single-Register Read from Specified Address

Fig. 4-21 shows a multiple register write to a specified address.

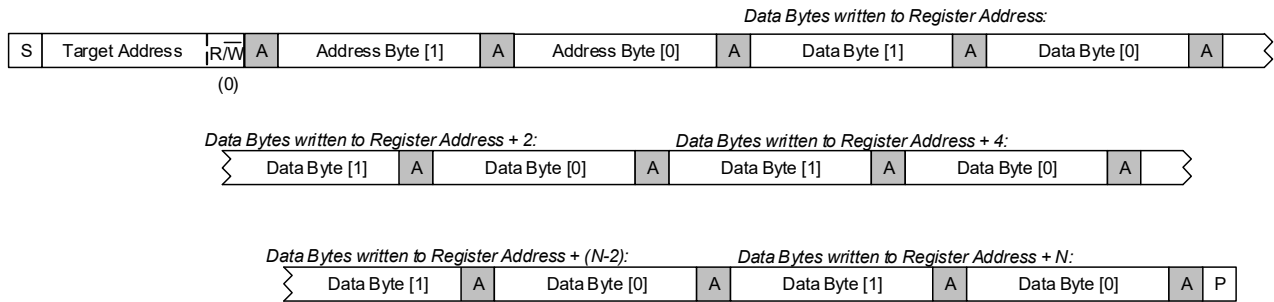

Figure 4-21. Multiple-Register Write to Specified Address

Fig. 4-22 shows a multiple register read from a specified address.

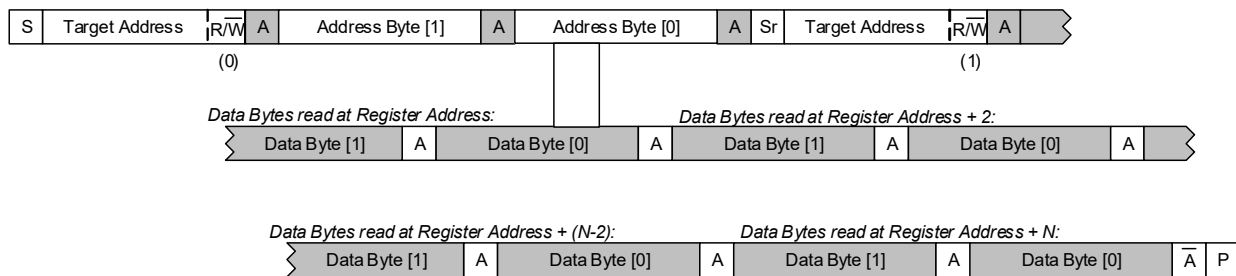

Figure 4-22. Multiple-Register Read from Specified Address

4.7.2 SPI Interface

The SPI interface is supported using the following pins, which must be configured for the SPI function if required:

- CONFIG1/SPI_CS
- CONFIG2/SPI_SDI/I2C_SDA
- CONFIG3/SPI_SDO/I2C_SCL
- SPI_SCK

To ensure that the control port is inactive prior to use, SPI_CS must be deasserted (i.e., Logic 1) during device startup; RESET must remain asserted (i.e., Logic_0) until SPI_CS is deasserted (i.e., Logic_1), timing information is provided in Table 3-10.

The SDI (data-input) pin supports the following behavior:

- In write operations ($R/\overline{W} = 0$), the SDI pin input is driven by the controlling device.
- In read operations ($R/\overline{W} = 1$), the SDI pin is ignored following receipt of the valid register address.

The SDO (data-output) pin supports the following behavior:

- If \overline{CS} is asserted (Logic 0), the SDO output is actively driven when outputting data and is high impedance at other times. If \overline{CS} is not asserted, the SDO output is high impedance.
- The high-impedance state of the SDO output allows the pin to be shared with other peripheral devices.
- The output (SDO) data bit is available to the host device at the rising edge of SCK. See Table 3-13 for timing information.

The SPI interface uses a 15-bit register address and 16-bit data words. The full SPI message protocol also includes a read/write bit and a 16-bit padding phase (see Fig. 4-23 and Fig. 4-24).

Continuous read and write modes enable multiple register operations to be scheduled faster than is possible with single register operations. In these modes, the CS4332B automatically increments the register address at the end of each data word, for as long as \overline{CS} is held low and SCK is toggled. Successive data words can be input/output every 16 clock cycles.

The SPI protocol is shown in Fig. 4-23 and Fig. 4-24.

Fig. 4-23 shows a single register write to a specified address.

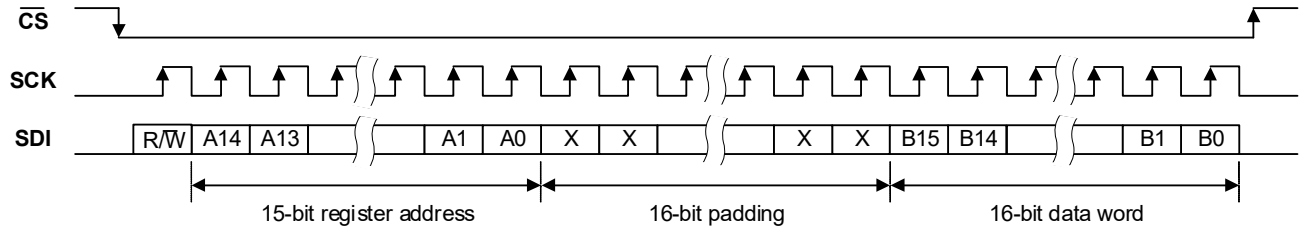

Figure 4-23. Control Interface SPI Register Write

Fig. 4-24 shows a single register read from a specified address.

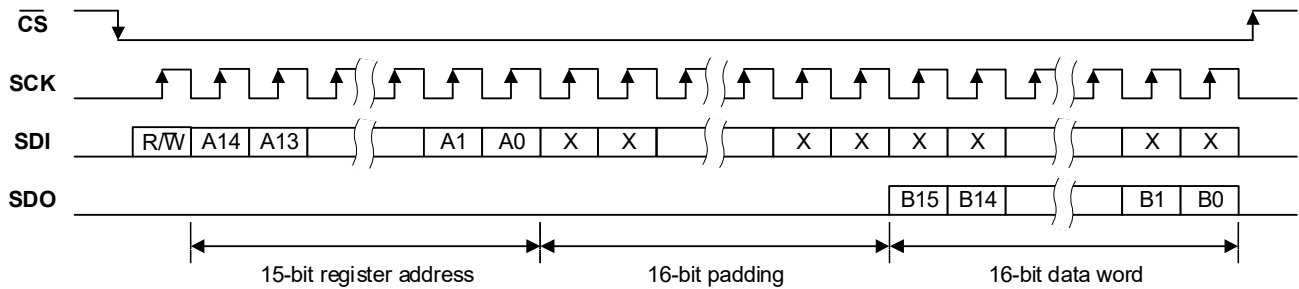

Figure 4-24. Control Interface SPI Register Read

Fig. 4-25 shows a multiple register write to a specified address.

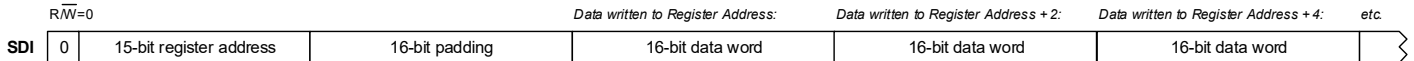

Figure 4-25. Multiple-Register Write to Specified Address

Fig. 4-26 shows a multiple register read from a specified address.

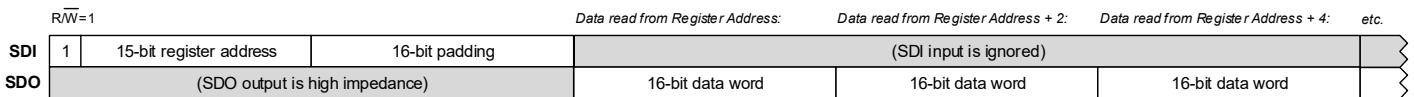

Figure 4-26. Multiple-Register Read from Specified Address

4.8 Device ID

The device ID, and other associated data, can be read from the control fields listed in Table 4-11.

Table 4-11. Device ID

Label	Description
DEVID_0	Lower bytes of the Device ID
DEVID_1	Upper bytes of the Device ID
AREVID	All-layer device revision
MTLREVID	Metal-layer device revision

5 Applications

5.1 Output Buffer Circuit

The CS4332B incorporates a high-performance sigma-delta current-mode DAC with integrated operational amplifiers for current-to-voltage conversion. External components for the current-to-voltage conversion and out-of-band filtering can be selected for flexible integration and to optimize dynamic range.

5.1.1 Typical Output Circuit

A typical output connection circuit is shown in Fig. 5-1. The circuit produces a $2 V_{RMS}$ differential output from a full-scale (0 dBFS) digital input.

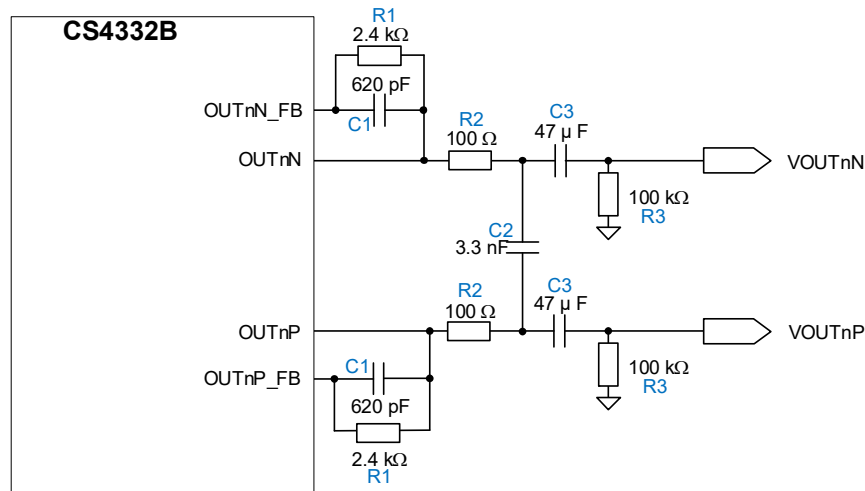

Figure 5-1. Typical Output Connection Circuit

The feedback resistor, R_1 determines the full-scale differential output voltage; a maximum output voltage of $2 V_{RMS}$ is supported at the OUTn and OUTnP pins. R_1 is calculated as follows:

$$R_1 = \frac{\text{Full-scale Output Voltage (} V_{RMS} \text{)}}{0.835 \text{ mA}_{RMS}} = \frac{2}{0.835 \times 10^{-3}} = 2.4 \text{ k}\Omega$$

The filter is provided by the integrated operational amplifiers and associated feedback components C_1 and R_1 . The objective is to provide a flat passband for the audio output bandwidth. The cut-off frequency of the filter is calculated as follows:

$$F_C = \frac{1}{2\pi R_1 C_1} = \frac{1}{2\pi \times 2400 \times 620 \times 10^{-12}} = 107 \text{ kHz}$$

R_2 and C_2 create an output filter to reduce out-of-band noise of the output. The cut-off frequency of the filter is calculated as follows:

$$F_C = \frac{1}{2\pi R_2 C_2} = \frac{1}{2\pi \times 100 \times (2 \times 3.3 \times 10^{-9})} = 241 \text{ kHz}$$

R_3 and C_3 form a high-pass filter, which removes the DC bias of the voltage output. The cut-off frequency of the filter is calculated as follows:

$$F_C = \frac{1}{2\pi R_3 C_3} = \frac{1}{2\pi \times 100 \times 10^3 \times 47 \times 10^{-6}} = 0.033 \text{ Hz}$$

5.1.2 Alternative Output Circuits

The typical circuit shown in Fig. 5-1 is recommended for optimal performance. Example line driver circuits are described in Section 5.1.2.1 and Section 5.1.2.2; specifications detailed in Section 3 are not applicable.

5.1.2.1 Example Active Differential Line Driver Circuit

An example of an active differential line-driver circuit is shown in Fig. 5-2, the output connection circuit shown produces a $2.2 V_{RMS}$ differential output from a full-scale (0 dBFS) digital input.

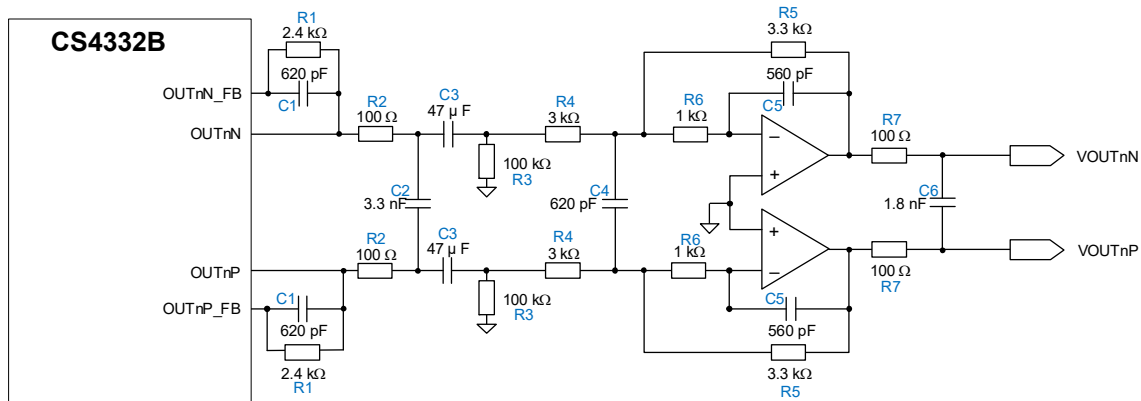

Figure 5-2. Example Active Differential Line Driver Circuit

The feedback resistor, R1 determines the full-scale differential output voltage; a maximum output voltage of $2 V_{RMS}$ is supported at the OUTnN and OUTnP pins. R1 is calculated as follows

$$R_1 = \frac{\text{Full-scale Output Voltage (} V_{RMS} \text{)}}{0.835 \text{ mA}_{RMS}} = \frac{2}{0.835 \times 10^{-3}} = 2.4 \text{ k}\Omega$$

The filter is provided by the integrated operational amplifiers and associated feedback components C1 and R1. The objective is to provide a flat passband for the audio output bandwidth. The cut-off frequency of the filter is calculated as follows:

$$F_C = \frac{1}{2\pi R_1 C_1} = \frac{1}{2\pi \times 2400 \times 620 \times 10^{-12}} = 107 \text{ kHz}$$

R2 and C2 create an output filter to reduce the out-of-band noise of the output. The cut-off frequency of the filter is calculated as follows:

$$F_C = \frac{1}{2\pi R_2 C_2} = \frac{1}{2\pi \times 100 \times (2 \times 3.3 \times 10^{-9})} = 241 \text{ kHz}$$

C3 removes the DC bias of the CS4332B output and forms a high-pass filter with parallel resistance of R3 and R4. The cut-off frequency of the filter is calculated as follows:

$$F_C = \frac{1}{2\pi \left(\frac{R_3 \times R_4}{R_3 + R_4} \right) C_3} = \frac{1}{2\pi \times \left(\frac{100 \times 10^3 \times 3 \times 10^3}{100 \times 10^3 + 3 \times 10^3} \right) \times 47 \times 10^{-6}} = 1.16 \text{ Hz}$$

R4 and C4 create a low-pass filter. The cut-off frequency of the filter is calculated as follows:

$$F_C = \frac{1}{2\pi R_4 C_4} = \frac{1}{2\pi \times 3 \times 10^3 \times (2 \times 620 \times 10^{-9})} = 42.8 \text{ kHz}$$

R5, R6, and C5 create a low-pass filter within the operational amplifier feedback loop. The cut-off frequency of the filter is calculated as follows:

$$F_C = \frac{1}{2\pi(R_5 + R_6)C_5} = \frac{1}{2\pi \times (3.3 \times 10^3 + 1 \times 10^3) \times 560 \times 10^{-9}} = 66.1 \text{ kHz}$$

The gain of the output buffer is set by R4 and R5:

$$\text{Gain} = \frac{R_5}{R_4} = \frac{3 \times 10^3}{3.3 \times 10^3} = 1.1$$

R7 and C6 limit the output current; this ensures stability of the output and filters any out-of-band noise introduced by the operational amplifiers. The cut-off frequency of the filter is calculated as follows:

$$F_C = \frac{1}{2\pi R_7 C_6} = \frac{1}{2\pi \times 100 \times (2 \times 1.8 \times 10^{-9})} = 442.1 \text{ kHz}$$

5.1.2.2 Example Active Differential-to-Single-Ended Line Driver Circuit

An example of an active differential-to-single-ended output circuit is shown in Fig. 5-3. The circuit produces a 2.2 V_{RMS} single-ended output from a full-scale (0 dBFS) digital input.

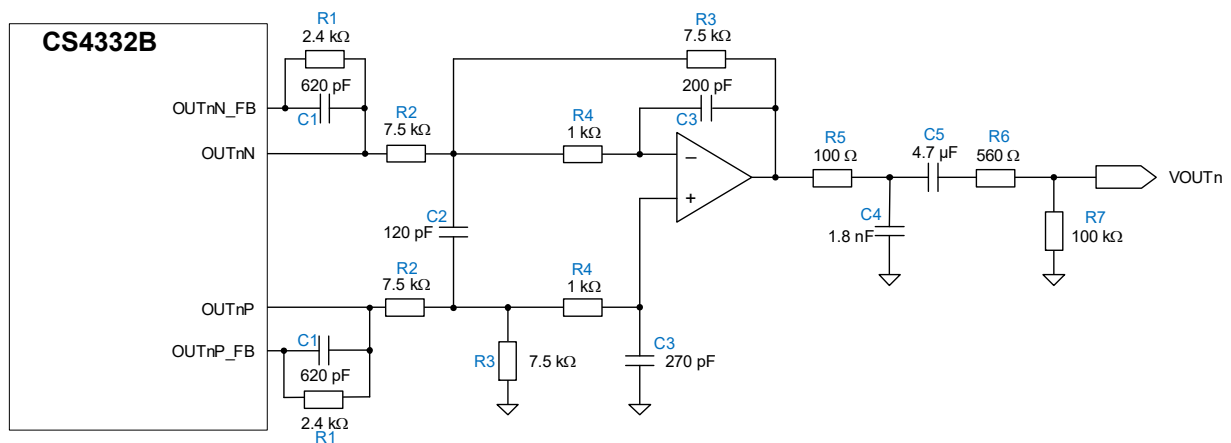

Figure 5-3. Example Differential-to-Single-Ended Output Circuit

The feedback resistor, R1 determines the full-scale differential output voltage; a maximum output voltage of 2 V_{RMS} is supported at the OUTnN and OUTnP pins. R1 is calculated as follows:

$$R_1 = \frac{\text{Full-scale Output Voltage (V}_{\text{RMS}})}{0.835 \text{ mA}_{\text{RMS}}} = \frac{2}{0.835 \times 10^{-3}} = 2.4 \text{ k}\Omega$$

The filter is provided by the integrated operational amplifiers and associated feedback components C1 and R1. The objective is to provide a flat passband for the audio output bandwidth. The cut-off frequency of the filter is calculated as follows:

$$F_C = \frac{1}{2\pi R_1 C_1} = \frac{1}{2\pi \times 2400 \times 620 \times 10^{-12}} = 107 \text{ kHz}$$

R2 and C2 create an output filter to reduce the out-of-band noise of the output. The cut-off frequency of the filter is calculated as follows:

$$F_C = \frac{1}{2\pi R_2 C_2} = \frac{1}{2\pi \times (7.5 \times 10^3) \times (2 \times 120 \times 10^{-12})} = 88.4 \text{ kHz}$$

R3, R4, and C3 create a low-pass filter. The cut-off frequency of the filter is calculated as follows:

$$F_C = \frac{1}{2\pi(R_3 + R_4)C_3} = \frac{1}{2\pi \times (7.5 \times 10^3 + 1 \times 10^3) \times 200 \times 10^{-9}} = 93.6 \text{ kHz}$$

The gain of the output buffer is set by R2 and R3:

$$\text{Gain} = \frac{R_3}{R_2} = \frac{7.5 \times 10^3}{7.5 \times 10^3} = 1$$

R5, R6, R7, C4, and C5 remove the DC bias of the CS4332B output, limit the output current, ensure stability of the output, and filter any out-of-band noise introduced by the operation amplifiers.

The cut-off frequency of the high-pass filter is calculated as follows:

$$F_C = \frac{1}{2\pi(R_6 + R_7)C_5} = \frac{1}{2\pi \times (560 + 100 \times 10^3) \times (47 \times 10^{-6})} = 0.03 \text{ Hz}$$

The cut-off frequency of the low-pass filter is calculated as follows:

$$F_C = \frac{1}{2\pi R_5 C_4} = \frac{1}{2\pi \times 100 \times (1.8 \times 10^{-9})} = 884.2 \text{ kHz}$$

5.1.3 Unused Output Pins

The typical output connection circuit (Fig. 5-1) provides a biased differential output. Alternative output buffer circuits may only provide a single-ended output configuration. In this case, or where an output channel is not used, any unused output pin (OUTnX) must be connected to its respective OUTnX_FB pin, as illustrated in Fig. 5-4.

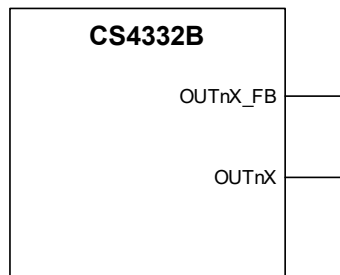

Figure 5-4. Unused Output Pin Connection

5.1.4 Recommended Components

To achieve the specified performance characteristics, the choice of external components should observe the following recommendations:

- Capacitors should be stable dielectric types, such as C0G (NP0) or electrolytic.
- Resistors should be low value where possible, to minimize thermal noise.
- Low-noise operational amplifiers should be used, such as Texas Instruments OPA1656. The operational amplifiers should meet the minimum performance requirements noted in Table 5-1.

Table 5-1. Op-Amp Specification

Parameter	Specification
Input noise	<5 nV/√Hz
Unity gain bandwidth	>15 MHz
Slew rate	5 V/μs
Total harmonic distortion plus noise (THD+N)	<-128 dB

5.2 Crystal Component Selection

The crystal oscillator (see [Section 4.4](#)) uses an external crystal to generate the timing reference. Load capacitors are connected to the crystal as shown in [Fig. 5-5](#). A series resistor (R_S) may also be required to configure the drive level for the selected crystal.

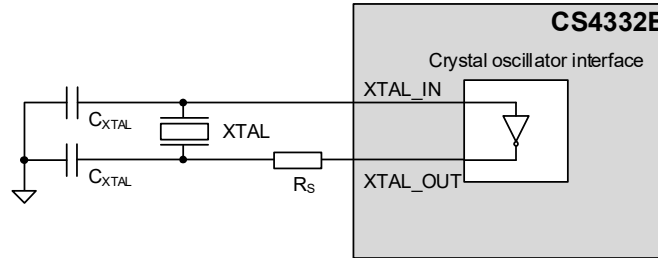

Figure 5-5. Crystal Oscillator Connection

The suitability of the selected crystal is determined by whether the gain margin and drive level are within the valid operating limits of the crystal. The gain margin and drive level can be calculated as a function of the transconductance of the crystal interface.

The transconductance of the crystal interface is dependent on the VDD_IO2 operating voltage as described in [Table 3-10](#).

The recommended sequence for crystal component selection is as follows:

1. **Crystal selection.** The CS4332B is compatible with a wide variety of crystal components, including the KC3225Z series of oscillators. Note that for a reference frequency of 45.1584 MHz a custom crystal may be required.
2. **Capacitor selection.** Capacitors should be selected according to the crystal manufacturer's specification for load capacitance (C_L). The recommended value for each C_{XTAL} capacitor is $2 \times C_L$.
3. **Series resistor.** In the first instance, assume the series resistor R_S is not required (0 Ω).
4. **Gain margin calculation.** The gain margin can be calculated from the transconductance of the crystal interface and the series resistor R_S , together with the crystal characteristics. If the required gain margin is less than 5, a different crystal selection must be made (Step 1).

The gain margin is calculated as follows:
$$\text{Gain Margin} = \frac{\text{Transconductance}}{4 \times (\text{ESR} + R_S) \times (2\pi \times f_{XTAL})^2 \times (C_0 + C_L)^2}$$

where:

Transconductance = transconductance of the crystal interface (S)

ESR = equivalent series resistance (ESR) of the crystal (Ω)

R_S = series resistance (Ω)

f_{XTAL} = resonant frequency of the crystal (Hz)

C_L = load capacitance of the crystal (F)

C_0 = shunt capacitance of the crystal (F)

5. **Drive level calculation.** The drive level can be calculated using the crystal characteristics and the operating voltage. The operating voltage (peak voltage across the crystal) can be determined using measurement or else by simulation. If the drive level exceeds the maximum level for the crystal, adjust the series resistor R_S to meet the required specification. Increasing R_S results in a lower voltage across the crystal and a decrease in drive level.

If the series resistor is adjusted, the gain margin must now be recalculated (Step 4). It is recommended to find the minimum series resistance that meets the required gain margin and drive level.

The drive level (W) is calculated as follows: $\text{Drive Level} = 2 \times \text{ESR} \times (\pi \times f_{\text{XTAL}} \times V \times (C_L + C_0))^2$

where:

ESR = equivalent series resistance (ESR) of the crystal (Ω)

f_{XTAL} = resonant frequency of the crystal (Hz)

V = Peak voltage across the crystal (V)

C_L = load capacitance of the crystal (F)

C_0 = shunt capacitance of the crystal (F)

The sequence for crystal component selection is illustrated in [Fig. 5-6](#)

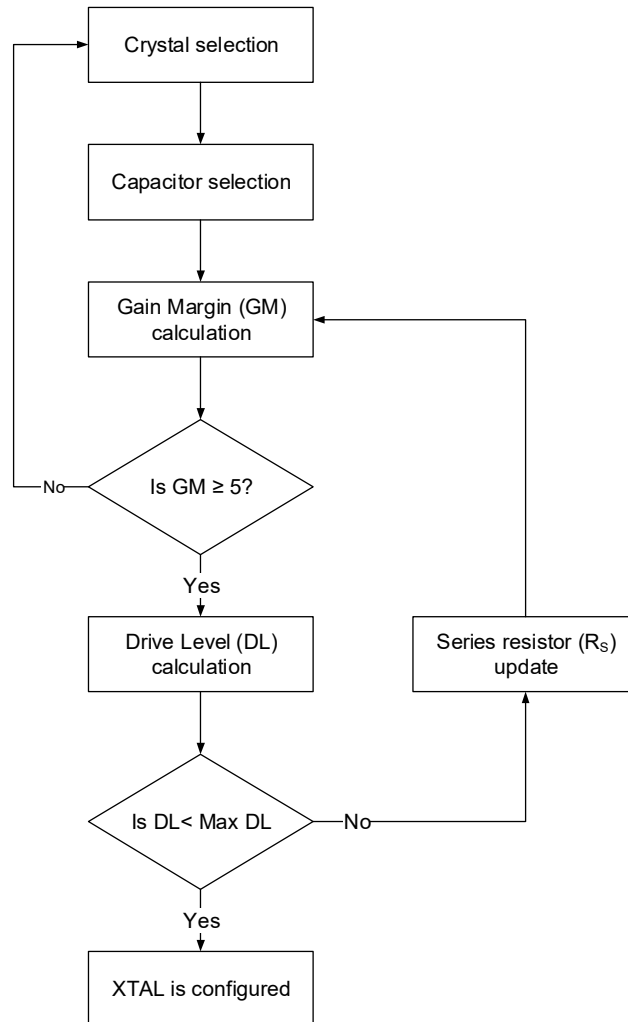

Figure 5-6. Crystal Oscillator Component Selection

6 Register Quick Reference

This section gives an overview of the control port registers. Refer to the following bit definition tables for bit assignment information.

This register view is for the CS4332B.

- The register field default values are established upon the deassertion of the $\overline{\text{RESET}}$ pin or following soft reset.
- A "—" represents a reserved field/access type.
- The reserved field values must not be modified.
- The registers are 16 bits wide, and only word transactions are allowed.
- All visible fields are read/write except where indicated with the following shading:

Read/write access
 Read-only access
 Write-only access

Table 6-1. Block Base Addresses

Base Address	Block Name	Register Quick Reference	Register Description Reference
0x0000 0000	DEVID	Section 6.1	Section 7.1
0x0000 0040	CONFIG	Section 6.2	Section 7.2
0x0000 00C0	OUTPUT_PATH	Section 6.3	Section 7.3

6.1 DEVID

Address	Register	15	14	13	12	11	10	9	8	7	6	5	4	3	2	1	0
0x0000 0000 p. 39	DEVID_0	DEVID_0															
		0	0	1	1	0	0	1	1	0	0	1	0	0	0	1	0
0x0000 0002 p. 39	DEVID_1	DEVID_1															
		0	0	0	0	0	0	0	0	0	0	0	0	0	1	0	0
0x0000 0004 p. 39	REVID	—								AREVID				MTLREVID			
		0	0	0	0	0	0	0	0	1	0	1	0	0	0	0	0
0x0000 0022 p. 40	SW_RESET	SW_RESET								—							
		0	0	0	0	0	0	0	0	0	0	0	0	0	0	0	0

6.2 CONFIG

Address	Register	15	14	13	12	11	10	9	8	7	6	5	4	3	2	1	0	
0x0000 0040 p. 40	CLK_CFG	—		SYSCLK_FREQ	SYSCLK_SRC	—												
		0	0	0	0	0	0	0	0	0	0	0	0	0	0	0	0	
0x0000 0042 p. 40	SAMPLE_RATE	—												SAMPLE_RATE				
		0	0	0	0	0	0	0	0	0	0	0	0	0	0	0	1	
0x0000 0044 p. 40	CHIP_ENABLE	—																
		0	0	0	0	0	0	0	0	0	0	0	0	0	0	0	0	
0x0000 0048 p. 41	ASP_CFG	—										ASP_BCLK_INV	ASP_PRIMARY	—			ASP_BCLK_FREQ	
		0	0	0	0	0	0	0	0	0	0	0	0	0	0	0	0	
0x0000 0050 p. 41	SIGNAL_PATH_CFG	—										ASP_FSYNC_TYPE	ASP_TDM_SLOT			ASP_FORMAT		
		0	0	0	0	0	0	0	0	0	0	0	0	0	0	0	0	

6.3 OUTPUT_PATH

Address	Register	15	14	13	12	11	10	9	8	7	6	5	4	3	2	1	0	
0x0000 00C0 p. 41	OUT_ENABLES	—							OUT_LOAD_CFG	—							OUT2_DAC_EN	OUT1_DAC_EN
		0	0	0	0	0	0	0	0	0	0	0	0	0	0	0	0	
0x0000 00C2 p. 42	OUT_RAMP_SUM	—							OUT_RAMP_RATE_DEC			—	OUT_RAMP_RATE_INC					
		0	0	0	0	0	0	0	0	0	0	1	0	0	0	1	0	
0x0000 00C4 p. 42	OUT_DEEMPH	—															OUT_DEEMPH_FILTER_SEL	OUT_DEEMPH_EN
		0	0	0	0	0	0	0	0	0	0	0	0	0	0	0	0	
0x0000 00CA p. 42	OUT_INV	—															OUT2_INV	OUT1_INV
		0	0	0	0	0	0	0	0	0	0	0	0	0	0	0	1	1
0x0000 00D0 p. 43	OUT1_VOL_CTRL	OUT1_MUTE	—							OUT1_VOL								
		1	0	0	0	0	0	0	0	0	0	0	0	0	0	0	0	
0x0000 00D2 p. 43	OUT2_VOL_CTRL	OUT2_MUTE	—							OUT2_VOL								
		1	0	0	0	0	0	0	0	0	0	0	0	0	0	0	0	
0x0000 00E0 p. 43	OUT_VOL_UPDATE	—															OUT_VU	
		0	0	0	0	0	0	0	0	0	0	0	0	0	0	0	0	
0x0000 00E4 p. 43	SHUTDOWN_CTRL1	—															DAC_SHUTDO WN	
		0	0	0	0	0	0	0	0	0	0	0	0	0	0	0	0	

7.1.4 SW_RESET
Address: 0x0000 0022

WO	15	14	13	12	11	10	9	8	7	6	5	4	3	2	1	0
	SW_RESET								—							
Default	0	0	0	0	0	0	0	0	0	0	0	0	0	0	0	0

Bits	Name	Description
15:8	SW_RESET	Software Reset. Writing 0x5A triggers a reset. 0x00 = (Default) No action 0x01–0x59 = Reserved 0x5A = Software reset 0x5B–0xFF = Reserved
7:0	—	Reserved

7.2 CONFIG
7.2.1 CLK_CFG
Address: 0x0000 0040

RW	15	14	13	12	11	10	9	8	7	6	5	4	3	2	1	0
	—		SYSCLK_FREQ	SYSCLK_SRC	—											
Default	0	0	0	0	0	0	0	0	0	0	0	0	0	0	0	0

Bits	Name	Description
15:14	—	Reserved
13	SYSCLK_FREQ	System clock frequency. 0 = (Default) 24.576/22.5792 MHz 1 = 49.152/45.1584 MHz
12	SYSCLK_SRC	System clock source. If XTAL is selected, the MCLK is the output clock. 0 = (Default) MCLK input 1 = XTAL input
11:0	—	Reserved

7.2.2 SAMPLE_RATE
Address: 0x0000 0042

RW	15...8	7	6	5	4	3	2	1	0	
	—	—							SAMPLE_RATE	
Default	0x00	0	0	0	0	0	0	0	1	

Bits	Name	Description
15:3	—	Reserved
2:0	SAMPLE_RATE	Audio sample frequency. Note the sample rate must be integer-related to the system clock frequency. Auto-detect is only valid if sample rate = 16-192 kHz, and the ASP is in Secondary Mode. 000 = 32 kHz 001 = (Default) 48/44.1 kHz 010 = 96/88.2 kHz 011 = 192/176.4 kHz 100 = 384/356.8 kHz 101 = Reserved 110 = Auto-detect 111 = 16 kHz

7.2.3 CHIP_ENABLE
Address: 0x0000 0044

RW	15...8	7	6	5	4	3	2	1	0	
	—	—							GLOBAL_EN	
Default	0x00	0	0	0	0	0	0	0	0	

Bits	Name	Description
15:1	—	Reserved
0	GLOBAL_EN	Global enable. Set to 1 to configure and enable all functions. Clear to 0 to disable. Note the clocking and ASP control registers are only valid on the rising edge of GLOBAL_EN. It is recommended to select the disabled state (GLOBAL_EN=0) before writing to these registers.

7.2.4 ASP_CFG
Address: 0x0000 0048

RW	15...8	7	6	5	4	3	2	1	0
	—	—	ASP_BCLK_INV	ASP_PRIMARY		—		ASP_BCLK_FREQ	
Default	0x00	0	0	0	0	0	0	0	0

Bits	Name	Description
15:7	—	Reserved
6	ASP_BCLK_INV	ASP BCLK polarity. Selects the valid BCLK edge for data sampling. In non-inverted mode, DIN data is valid on BCLK rising edge. In inverted mode, DIN data is valid on BCLK falling edge. 0 = (Default) Non-inverted 1 = Inverted
5	ASP_PRIMARY	ASP Primary/Secondary Mode select. In ASP Primary Mode, BCLK and FSYNC are outputs. In ASP Secondary Mode, BCLK and FSYNC are inputs. 0 = (Default) Secondary Mode 1 = Primary Mode
4:2	—	Reserved
1:0	ASP_BCLK_FREQ	ASP BCLK frequency. The BCLK frequency must be high enough to support the required number of data bits at the selected sample rate. Only valid in ASP Primary Mode. Note the BCLK frequency is integer-related to the system clock frequency i.e., multiples of 3.072 MHz for 24.576 / 49.152 MHz system clock, or multiples of 2.8224 MHz for 22.5792 / 45.1584 MHz system clock. 00 = (Default) 3.072/2.8224 MHz 01 = 6.144/5.6448 MHz 10 = 12.288/11.2896 MHz 11 = 24.576/22.5792 MHz

7.2.5 SIGNAL_PATH_CFG
Address: 0x0000 0050

RW	15...8	7	6	5	4	3	2	1	0
	—	—	ASP_FSYNC_TYPE	ASP_TDM_SLOT			ASP_FORMAT		
Default	0x00	0	0	0	0	0	0	0	0

Bits	Name	Description
15:7	—	Reserved
6	ASP_FSYNC_TYPE	Configure ASP_FSYNC as pulse or square wave (50% duty cycle) in TDM mode. Only applicable when ASP is in Primary Mode. 0 = (Default) FSYNC Pulse 1 = FSYNC Square Wave
5:3	ASP_TDM_SLOT	TDM slot select. Configures which TDM slots are used in TDM maximum-time-slots mode. 000 = (Default) Slots 0-1 001 = Slots 2-3 010 = Slots 4-5 011 = Slots 6-7 100 = Slots 8-9 101 = Slots 10-11 110 = Slots 12-13 111 = Slots 14-15
2:0	ASP_FORMAT	ASP data format. Selects how the audio samples are arranged within the FSYNC frame. 000 = (Default) I2S Mode 001 = Left-Justified Mode 010–101 = Reserved 110 = TDM Mode maximum time slots 111 = TDM Mode minimum time slots

7.3 OUTPUT_PATH
7.3.1 OUT_ENABLES
Address: 0x0000 00C0

RW	15	14	13	12	11	10	9	8	7	6	5	4	3	2	1	0	
								OUT_LOAD_CFG								OUT2_DAC_EN	OUT1_DAC_EN
Default	0	0	0	0	0	0	0	0	0	0	0	0	0	0	0	0	

Bits	Name	Description
15:9	—	Reserved
8	OUT_LOAD_CFG	Output driving configuration. 0 = (Default) 3k load 1 = 10k load

Bits	Name	Description
7:2	—	Reserved
1	OUT2_DAC_EN	Channel 2 output enable. 0 = (Default) Disabled 1 = Enabled
0	OUT1_DAC_EN	Channel 1 output enable. 0 = (Default) Disabled 1 = Enabled

7.3.2 OUT_RAMP_SUM
Address: 0x0000 00C2

RW	15...8	7	6	5	4	3	2	1	0
	—	—	OUT_RAMP_RATE_DEC			—	OUT_RAMP_RATE_INC		
Default	0x00	0	0	1	0	0	0	1	0

Bits	Name	Description
15:7	—	Reserved
6:4	OUT_RAMP_RATE_DEC	DAC output volume decrease Ramp Rate (ms/6 dB), used for gain changes. This field should not be changed while a volume ramp is in progress. 000 = 0 ms 001 = 0.5 ms 010 = (Default) 1 ms 011 = 2 ms 100 = 4 ms 101 = 8 ms 110 = 15 ms 111 = 30 ms
3	—	Reserved
2:0	OUT_RAMP_RATE_INC	DAC output volume increase Ramp Rate (ms/6 dB), used for gain changes. This field should not be changed while a volume ramp is in progress. 000 = 0 ms 001 = 0.5 ms 010 = (Default) 1 ms 011 = 2 ms 100 = 4 ms 101 = 8 ms 110 = 15 ms 111 = 30 ms

7.3.3 OUT_DEEMPH
Address: 0x0000 00C4

RW	15...8	7	6	5	4	3	2	1	0
	—	—						OUT_DEEMPH_FILT_SEL	OUT_DEEMPH_EN
Default	0x00	0	0	0	0	0	0	0	0

Bits	Name	Description
15:2	—	Reserved
1	OUT_DEEMPH_FILT_SEL	Deemphasis filter sample-rate selection. 0 = (Default) 44.1 kHz 1 = 48.0 kHz
0	OUT_DEEMPH_EN	Deemphasis filter enable. 0 = (Default) Deemphasis disabled 1 = Deemphasis enabled

7.3.4 OUT_INV
Address: 0x0000 00CA

RW	15...8	7	6	5	4	3	2	1	0
	—	—						OUT2_INV	OUT1_INV
Default	0x00	0	0	0	0	0	0	1	1

Bits	Name	Description
15:2	—	Reserved
1	OUT2_INV	Channel 2 DAC invert. 0 = No inversion 1 = (Default) DAC data invert
0	OUT1_INV	Channel 1 DAC invert. 0 = No inversion 1 = (Default) DAC data invert

7.3.5 OUT1_VOL_CTRL
Address: 0x0000 00D0

RW	15	14	13	12	11	10	9	8	7	6	5	4	3	2	1	0
	OUT1_MUTE	—							OUT1_VOL							
Default	1	0	0	0	0	0	0	0	0	0	0	0	0	0	0	0

Bits	Name	Description
15	OUT1_MUTE	DAC output Channel 1 mute. 0 = Unmute 1 = (Default) Mute
14:8	—	Reserved
7:0	OUT1_VOL	DAC output Channel 1 volume, -127.5 dB to 0 dB in 0.5 dB steps. 0x00 = (Default) 0.0 dB 0x01 = -0.5 dB ... 0xFF = -127.5 dB

7.3.6 OUT2_VOL_CTRL
Address: 0x0000 00D2

RW	15	14	13	12	11	10	9	8	7	6	5	4	3	2	1	0
	OUT2_MUTE	—							OUT2_VOL							
Default	1	0	0	0	0	0	0	0	0	0	0	0	0	0	0	0

Bits	Name	Description
15	OUT2_MUTE	DAC output Channel 2 mute. 0 = Unmute 1 = (Default) Mute
14:8	—	Reserved
7:0	OUT2_VOL	DAC output Channel 2 volume, -127.5 dB to 0 dB in 0.5 dB steps. 0x00 = (Default) 0.0 dB 0x01 = -0.5 dB ... 0xFF = -127.5 dB

7.3.7 OUT_VOL_UPDATE
Address: 0x0000 00E0

WO	15...8	7	6	5	4	3	2	1	0
	—	—							OUT_VU
Default	0x00	0	0	0	0	0	0	0	0

Bits	Name	Description
15:1	—	Reserved
0	OUT_VU	Global output volume update trigger. 0 = (Default) No action 1 = Write 1 to trigger an update of all output volume/mute registers

7.3.8 SHUTDOWN_CTRL1
Address: 0x0000 00E4

RW	15...8	7	6	5	4	3	2	1	0
	—	—							DAC_SHUTDOWN
Default	0x00	0	0	0	0	0	0	0	0

Bits	Name	Description
15:1	—	Reserved
0	DAC_SHUTDOWN	DAC reference shutdown control. Can be used to minimize power consumption if all output paths are disabled. 0 = (Default) Enable DAC reference 1 = Shutdown DAC reference

8 Thermal Characteristic

Table 8-1. Typical JEDEC Four-Layer, 2s2p Board Thermal Characteristics

Parameter	Symbol	QFN	Units
Junction-to-ambient thermal resistance	θ_{JA}	32.59	$^{\circ}\text{C}/\text{W}$
Junction-to-board thermal resistance	θ_{JB}	19.57	$^{\circ}\text{C}/\text{W}$
Junction-to-case (top) thermal resistance	θ_{JC}	98.16	$^{\circ}\text{C}/\text{W}$
Junction-to-board thermal-characterization parameter	Ψ_{JB}	18.28	$^{\circ}\text{C}/\text{W}$
Junction-to-package-top thermal-characterization parameter	Ψ_{JT}	3.89	$^{\circ}\text{C}/\text{W}$

Notes:

- Natural convection at the maximum recommended operating temperature T_A (see Table 3-2)
- Four-layer, 2s2p PCB as specified by JESD51-9 and JESD51-11; dimensions: 101.5 x 114.5 x 1.6 mm
- Thermal parameters as defined by JESD51-12

9 Package Dimensions

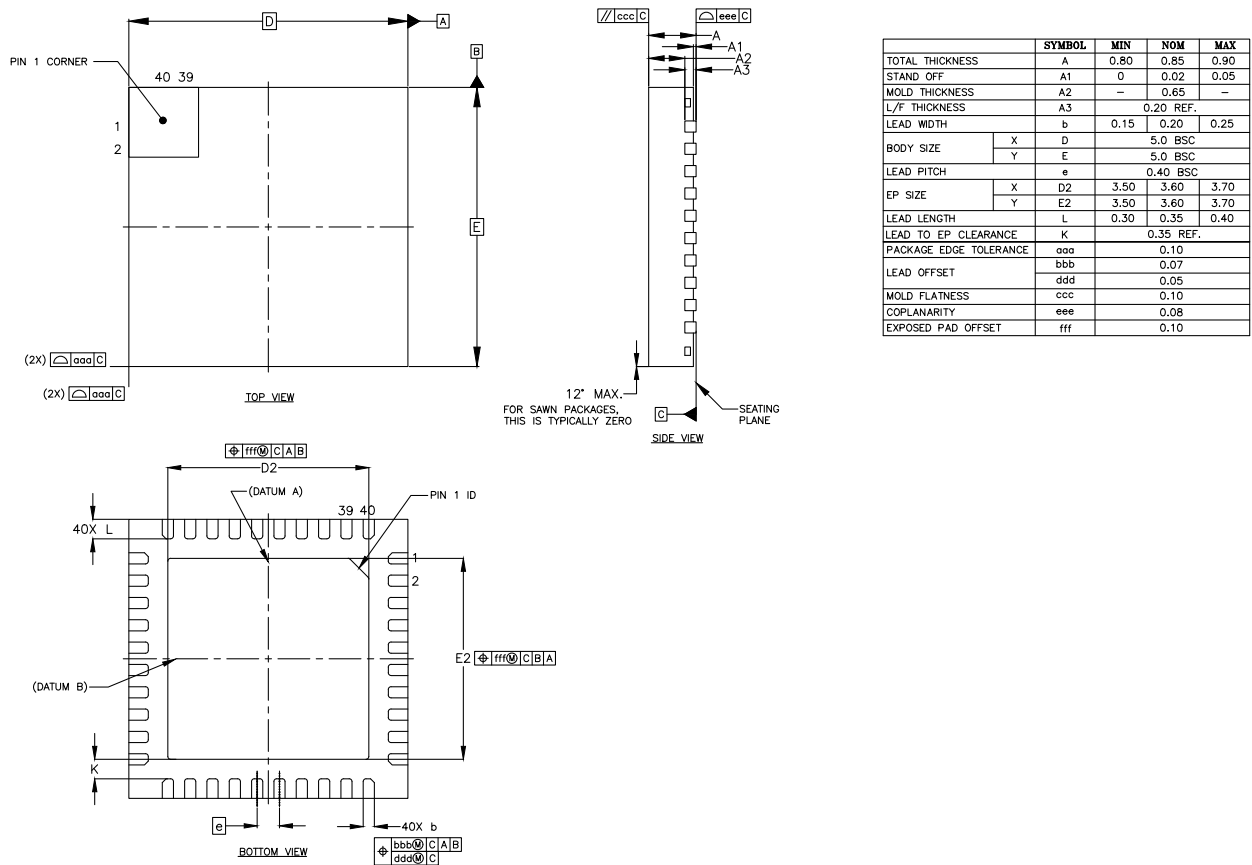
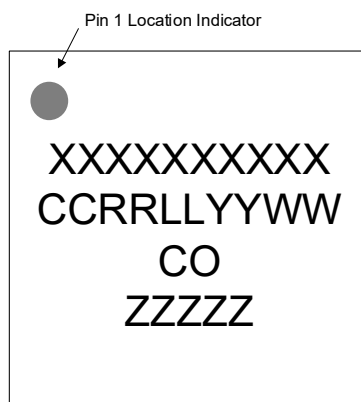

Figure 9-1. QFN Package Drawing

10 Package Marking

Figure 10-1. Package Marking



Top Side Brand

Line 1: Part number
 Line 2: Package mark
 Line 3: Country of origin (CO)
 Line 4: Encoded wafer/device ID

Package Mark Fields

CC = Cirrus Logic Index Code
 RR = Device revision code
 LL = Lot sequence code
 YY = Year of manufacture
 WW = Work week of manufacture

11 Ordering Information

Table 11-1. Ordering Information

Product	Description	Package	Environmental Certifications	Grade	Temperature Range	Container	Orderable Part Number
CS4332B	High Performance Two-Channel Audio DAC	40-pin QFN	RoHS Compliant	Commercial	-40 to +85°C	Tray	CS4332B-DN
						Tape and Reel	CS4332B-DNR

12 References

- NXP Semiconductors, UM10204 Rev. 7, October 2021, *I2C-Bus Specification and User Manual*, <http://www.nxp.com>

13 Revision History

Important: Please check www.cirrus.com or with your Cirrus Logic sales representative to confirm that you are using the latest revision of this document and to determine whether there are errata associated with this device.

Table 13-1. Revision History

Revision	Change
A2 MAY 2026	• Released for public distribution
A1 NOV 2025	• Initial version

Contacting Cirrus Logic Support

For all product questions and inquiries, contact a Cirrus Logic Sales Representative.

To find one nearest you, go to www.cirrus.com.

IMPORTANT NOTICE

"Advance" product information describes products that are in development and subject to substantial development changes. For the purposes of our terms and conditions of sale, "Preliminary" or "Advanced" datasheets are nonfinal datasheets that include, but are not limited to, datasheets marked as "Target", "Advance", "Product Preview", "Preliminary Technical Data" and/or "Preproduction." Products provided with any such datasheet are therefore subject to relevant terms and conditions associated with "Preliminary" or "Advanced" designations, as set out in our terms and conditions of sale, including but not limited to that Cirrus Logic expressly disclaims any warranties with respect to such products. The products and services of Cirrus Logic International (UK) Limited; Cirrus Logic, Inc.; and other companies in the Cirrus Logic group (collectively either "Cirrus Logic" or "Cirrus") are sold subject to Cirrus Logic's terms and conditions of sale supplied at the time of order acknowledgment, including those pertaining to warranty, indemnification, and limitation of liability. Software is provided pursuant to applicable license terms. Cirrus Logic reserves the right to make changes to its products and specifications or to discontinue any product or service without notice. Customers should therefore obtain the latest version of relevant information from Cirrus Logic to verify that the information is current and complete. Testing and other quality control techniques are utilized to the extent Cirrus Logic deems necessary. Specific testing of all parameters of each device is not necessarily performed. In order to minimize risks associated with customer applications, the customer must use adequate design and operating safeguards to minimize inherent or procedural hazards. Cirrus Logic is not liable for applications assistance or customer product design. The customer is solely responsible for its overall product design, end-use applications, and system security, including the specific manner in which it uses Cirrus Logic components. Certain uses or product designs may require an intellectual property license from a third party. Features and operations described herein are for illustrative purposes only and do not constitute a suggestion or instruction to adopt a particular product design or a particular mode of operation for a Cirrus Logic component.

CIRRUS LOGIC PRODUCTS ARE NOT DESIGNED, TESTED, INTENDED OR WARRANTED FOR USE (1) WITH OR IN IMPLANTABLE PRODUCTS OR FDA/ MHRA CLASS III (OR EQUIVALENT CLASSIFICATION) MEDICAL DEVICES, OR (2) IN ANY PRODUCTS, APPLICATIONS OR SYSTEMS, INCLUDING WITHOUT LIMITATION LIFE-CRITICAL MEDICAL EQUIPMENT OR SAFETY OR SECURITY EQUIPMENT, WHERE MALFUNCTION OF THE PRODUCT COULD CAUSE PERSONAL INJURY, DEATH, SEVERE PROPERTY DAMAGE OR SEVERE ENVIRONMENTAL HARM. INCLUSION OF CIRRUS LOGIC PRODUCTS IN SUCH APPLICATIONS IS UNDERSTOOD TO BE FULLY AT THE CUSTOMER'S RISK AND CIRRUS LOGIC DISCLAIMS AND MAKES NO WARRANTY, EXPRESS, STATUTORY OR IMPLIED, INCLUDING THE IMPLIED WARRANTIES OF MERCHANTABILITY AND FITNESS FOR PARTICULAR PURPOSE, WITH REGARD TO ANY CIRRUS LOGIC PRODUCT THAT IS USED IN SUCH A MANNER. IF THE CUSTOMER OR CUSTOMER'S CUSTOMER USES OR PERMITS THE USE OF CIRRUS LOGIC PRODUCTS IN SUCH A MANNER, CUSTOMER AGREES, BY SUCH USE, TO FULLY INDEMNIFY CIRRUS LOGIC, ITS OFFICERS, DIRECTORS, EMPLOYEES, DISTRIBUTORS AND OTHER AGENTS FROM ANY AND ALL LIABILITY, INCLUDING ATTORNEYS' FEES AND COSTS, THAT MAY RESULT FROM OR ARISE IN CONNECTION WITH THESE USES.

This document is the property of Cirrus Logic, and you may not use this document in connection with any legal analysis concerning Cirrus Logic products described herein. No license to any technology or intellectual property right of Cirrus Logic or any third party is granted herein, including but not limited to any patent right, copyright, mask work right, or other intellectual property rights. Any provision or publication of any third party's products or services does not constitute Cirrus Logic's approval, license, warranty or endorsement thereof. Cirrus Logic gives consent for copies to be made of the information contained herein only for use within your organization with respect to Cirrus Logic integrated circuits or other products of Cirrus Logic, and only if the reproduction is without alteration and is accompanied by all associated copyright, proprietary and other notices and conditions (including this notice). This consent does not extend to other copying such as copying for general distribution, advertising or promotional purposes, or for creating any work for resale. This document and its information is provided "AS IS" without warranty of any kind (express or implied). All statutory warranties and conditions are excluded to the fullest extent possible. No responsibility is assumed by Cirrus Logic for the use of information herein, including use of this information as the basis for manufacture or sale of any items, or for infringement of patents or other rights of third parties. Cirrus Logic, Cirrus, the Cirrus Logic logo design, and SoundClear are among the trademarks of Cirrus Logic. Other brand and product names may be trademarks or service marks of their respective owners.

Copyright © 2025–2026 Cirrus Logic, Inc. and Cirrus Logic International Semiconductor Ltd. All rights reserved.

SPI is a trademark of Motorola.